

10¢

A STREET & SMITH PUBLICATION

REG. U. S. PAT. OFFICE

JULY

BILL BARNES

Air Adventurer

CONTENTS
COPYRIGHTED
1933



WINGS OF THE JUNGLE

BY GEORGE L. EATON

also

MODEL DEPARTMENT

BY CORDON S. LIGHT

QUESTIONS AND ANSWERS

BY CLYDE PANCBORN

AIR ADVENTURERS CLUB

BY ALBERT J. CARLSON



6 WEEKS AGO

SO LONG SKINNY

TODAY
HEIGHT, 5 FT. 9 IN.
WEIGHT, 165 LBS.



CHEST
40 1/2 IN.

NECK
15 1/2 IN.

WAIST
31 IN.

THIGH
22 IN.

CALF
15 IN.

ANKLE
8 1/2

Painted by professional models

Skinny? New easy way adds solid pounds — so fast you're amazed!

Astonishing gains with new double tonic. Richest imported brewers' ale yeast concentrated 7 times and iron added. Gives 5 to 15 lbs. in a few weeks.

NOW there's no need to have people calling you "skinny," and losing all your chances of making friends. Here's a new, easy treatment that is giving thousands solid flesh and husky, good looks—in just a few weeks.

As you know, doctors for years have prescribed yeast to build up health. But now with this new discovery you can get far greater tonic results than with ordinary yeast—regain health, and also put on pounds of firm, good-looking flesh—and in a far shorter time.

Not only are thousands quickly gaining husky, handsome pounds, but also clear, radiant skin, freedom from indigestion and constipation, new strength and pep.

Concentrated 7 times

This amazing new product, Ironized Yeast, is made from specially cultured brewers' ale yeast imported from Europe—the richest yeast known—which by a new process is concentrated 7 times—made 7 times more powerful.

But that is not all! This super-rich yeast is then scientifically blended with 3 special kinds of iron which strengthen the blood.

Day after day, as you take Ironized Yeast, watch flat chest develop, sinewy limbs round out attractively, skin clear, new pep come—you're an entirely new person.

Results Guaranteed

No matter how skinny and weak you may be, this marvelous new Ironized Yeast should build you up in a few short weeks as it has thousands. If you are not delighted with the results of the very first package, your money will be instantly refunded.

Special FREE offer!

To start you building up your health *right now*, we make this absolutely FREE offer. Purchase a package of Ironized Yeast at once, cut out the seal on the box and mail it to us with a clipping of this paragraph. We will send you a fascinating new book on health, "New Facts About Your Body," by a well-known authority. Remember, results guaranteed with the very first package—or money back! At all druggists, Ironized Yeast Company, Inc., Dept. 506, Atlanta, Ga.

● IS THIS THE WAY YOU FEEL

about your job?



You will never catch any fish while sleeping—and you will never make any more money just going through the motions of your job! You've got to be wide-awake these days. The slightest nibble may be your biggest opportunity. Be alert to it and trained to take advantage of it. You

need training to get opportunities! All over the world men have realized this simple truth and are acquiring training through spare-time study of I. C. S. Courses. Their example—and this coupon—suggests a definite course of self-service to you.

INTERNATIONAL CORRESPONDENCE SCHOOLS

"The Universal University"

BOX 4901-G, SCRANTON, PENNA.



Without cost or obligation, please send me a copy of your booklet, "Who Wins and Why," and full particulars about the subject before which I have marked X:



TECHNICAL AND INDUSTRIAL COURSES

- | | | | | |
|--|---|--|--|--|
| <input type="checkbox"/> Architect | <input type="checkbox"/> Heat Treatment of Metals | <input type="checkbox"/> Plumbing | <input type="checkbox"/> Steam Fitting | <input type="checkbox"/> Bridge Engineer |
| <input type="checkbox"/> Architectural Draftsman | <input type="checkbox"/> Sheet Metal Worker | <input type="checkbox"/> Heating | <input type="checkbox"/> Ventilation | <input type="checkbox"/> Bridge and Building Foreman |
| <input type="checkbox"/> Building Estimating | <input type="checkbox"/> Telegraph Engineer | <input type="checkbox"/> Air Conditioning | | <input checked="" type="checkbox"/> Chemistry |
| <input type="checkbox"/> Contractor and Builder | <input type="checkbox"/> Telephone Work | <input type="checkbox"/> Steam Engineer | | <input type="checkbox"/> Coal Mining |
| <input type="checkbox"/> Structural Draftsman | <input type="checkbox"/> Mechanical Engineering | <input type="checkbox"/> Steam Electric Engineer | | <input type="checkbox"/> Mine Foreman |
| <input type="checkbox"/> Structural Engineer | <input type="checkbox"/> Mechanical Draftsman | <input type="checkbox"/> Marine Engineer | | <input type="checkbox"/> Navigation |
| <input type="checkbox"/> How to Invent and Patent | <input type="checkbox"/> Machinist | <input type="checkbox"/> R. R. Locomotives | | <input type="checkbox"/> Cotton Manufacturing |
| <input type="checkbox"/> Electrical Engineer | <input type="checkbox"/> Patternmaker | <input type="checkbox"/> R. R. Section Foreman | | <input type="checkbox"/> Woolen Manufacturing |
| <input type="checkbox"/> Electric Lighting | <input type="checkbox"/> Gas Engines | <input type="checkbox"/> Air Brakes | <input type="checkbox"/> R. R. Signalmen | <input type="checkbox"/> Agriculture |
| <input type="checkbox"/> Welding, Electric and Gas | <input type="checkbox"/> Aviation Engines | <input type="checkbox"/> Highway Engineering | | <input type="checkbox"/> Fruit Growing |
| <input type="checkbox"/> Reading Shop Blueprints | <input type="checkbox"/> Automobile Mechanic | <input type="checkbox"/> Civil Engineering | | <input type="checkbox"/> Poultry Farming |
| <input type="checkbox"/> Boilermaker | <input type="checkbox"/> Refrigeration | <input type="checkbox"/> Surveying and Mapping | | |

BUSINESS TRAINING COURSES

- | | | | |
|--|---|---|--|
| <input type="checkbox"/> Business Management | <input type="checkbox"/> C. P. Accountant | <input type="checkbox"/> Service Station Salesmanship | <input type="checkbox"/> Railway Mail Clerk |
| <input type="checkbox"/> Office Management | <input type="checkbox"/> Bookkeeping | <input type="checkbox"/> First Year College | <input type="checkbox"/> Grade School Subjects |
| <input type="checkbox"/> Industrial Management | <input type="checkbox"/> Secretarial Work | <input type="checkbox"/> Business Correspondence | <input type="checkbox"/> High School Subjects |
| <input type="checkbox"/> Traffic Management | <input type="checkbox"/> Spanish | <input type="checkbox"/> Lettering Show Cards | <input type="checkbox"/> College Preparatory |
| <input type="checkbox"/> Accountancy | <input type="checkbox"/> Salesmanship | <input type="checkbox"/> Stenography and Typing | <input type="checkbox"/> Illustrating |
| <input type="checkbox"/> Cost Accountant | <input type="checkbox"/> Advertising | <input type="checkbox"/> Civil Service | <input type="checkbox"/> Cartooning |
| | | <input type="checkbox"/> Mail Carrier | |

Name.....Age.....Address.....

City.....State.....Present Position.....

If you reside in Canada, send this coupon to the International Correspondence Schools Canadian, Limited, Montreal, Canada

On Sale Second Wednesday of Each Month

Volume III
Number 6

BILL BARNES

JULY
1935

AIR ADVENTURER

Reg. U. S. Pat. Off.

A STREET & SMITH PUBLICATION

The entire contents of this magazine are protected by copyright, and must not be reprinted without the publishers' permission.

Contents

Bill Barnes Air Novel:

Wings Of The Jungle 8

Out of the shadowy past comes intrigue that carries Bill Barnes to far-away Madagascar to right a wrong. Some one is determined his fleet shall never arrive at its destination and the air adventurers must shoot their way—through terrific odds.

by George L. Eaton

Also:

THE PLANE ON THE COVER	7
AIR ALIBI (Short Story)	89
<i>by Frank Piazza</i>	
THE AIRPORT IN THE VALLEY (Short Story)	98
<i>by Roger M. Clancy</i>	
DO YOU KNOW THAT—	107
THE AIR ADVENTURERS' CLUB	108
<i>Conducted by Albert J. Carlson</i>	
CONTEST MODELS	110
<i>Department conducted by Gordon S. Light</i>	
WHAT'S YOUR QUESTION?	118
<i>Conducted by Clyde Pangborn</i>	
THE CORSAIR JUNIOR	120
CY HAWKINS, AIR ADVENTURER	124
<i>by Frank Tinsley</i>	

Single Copy, 10 Cents

Yearly Subscription, \$1.00

Monthly publication issued by Street & Smith Publications, Inc., 79-89 Seventh Avenue, New York, N. Y. George C. Smith, Jr., President; Ormond V. Gould, Vice President and Treasurer; Ardenas Holmes, Vice President and Secretary; Clarence C. Vernam, Vice President. Copyright, 1935, by Street & Smith Publications, Inc., New York. Copyright, 1935, by Street & Smith Publications, Inc., Great Britain. Subscriptions to Cuba, Dom. Republic, Haiti, Spain, Central and South American Countries except The Guianas and British Honduras, \$1.25 per year. To all other Foreign Countries, including The Guianas and British Honduras, \$1.75 per year.

We do not accept responsibility for the return of unsolicited manuscripts.

To facilitate handling, the author should inclose a self-addressed envelope with the requisite postage attached.
STREET & SMITH PUBLICATIONS, INC., 79 7th AVE., NEW YORK, N. Y.

BUY NOW!

at these

LOW PRICES

\$2.15
29X4.40-21

\$3.45
BALLOON
32X6.00-20

\$4.25
HEAVY DUTY
TRUCK TIRES
30X5

\$7.95
TRUCK TIRES
32X6

WE WANT DEALERS

All Tubes are

Guaranteed

Brand New

Save on **GOODRICH Firestone**
GOOD YEAR
U.S., FISK and OTHERS

BUY NOW BEFORE TIRE PRICES ADVANCE!

Check these low prices! We do not believe any-one at the present time can match these tire values. Every tire is reconstructed in one of the best equipped and modern plants in the country. Our tires, under actual road test, prove their value. Every tire guaranteed to give twelve months satisfactory service or replaced at half price.

\$2.45
BALLOON
28X4.75-19

\$2.90
BALLOON
28X5.25-18

12 MONTHS WRITTEN GUARANTY With Each TIRE

BALLOON TIRES

Size	Rim	Tires	Tubes	Size	Rim	Tires	Tubes
29x4.40x21		\$2.15	\$0.85	27x5.50-17		\$3.35	\$1.15
29x4.50-20		2.35	.85	28x5.50-18		3.35	1.15
30x4.50-21		2.40	.85	29x5.50-19		3.35	1.15
28x4.75-19		2.45	.95	30x5.50-20		3.35	1.15
29x4.75-20		2.50	.95	x6.00-16		3.75	1.45
29x5.00-19		2.85	1.05	29x6.00-17		3.40	1.15
30x5.00-20		2.85	1.05	30x6.00-18		3.40	1.15
32x5.00-22		3.65	1.05	31x6.00-19		3.40	1.15
27x5.25-17		2.90	1.15	32x6.00-20		3.45	1.25
28x5.25-18		2.90	1.15	33x6.00-21		3.65	1.25
29x5.25-19		2.95	1.15	29x6.50-17		3.45	1.35
30x5.25-20		2.95	1.15	30x6.50-18		3.50	1.35
31x5.25-21		3.25	1.15	31x6.50-19		3.60	1.35

Size	Rim	Tires	Tubes
32x6.50-20		\$3.75	\$1.35
31x7.00-17		3.95	1.55
34x7.00-20		4.60	1.65
35x7.00-21		4.60	1.65

Regular Cord Tires

Size	Tires	Tubes
30x3 1/2	\$2.35	\$0.75
31x4	2.95	.85
32x4	2.95	.85
33x4	2.95	.85
34x4	3.25	.85
32x3 1/2	2.70	.80
32x4 1/2	3.35	1.15
33x4 1/2	3.45	1.15
34x4 1/2	3.45	1.15
30x5	3.65	1.35
33x5	3.75	1.45
35x5	3.95	1.55

Truck Balloons

Size	Tires	Tubes
6.00-20	\$3.75	\$1.65
6.50-20	4.45	1.95
7.00-20	5.95	2.95
7.50-20	6.95	3.75
8.25-20	8.95	4.95
9.00-20	10.95	5.65
9.75-20	13.95	6.45

Heavy Duty Trucks

Size	Tires	Tubes
30x5	\$4.25	\$1.95
34x5	4.25	2.00
32x6	7.95	2.75
36x6	9.95	3.95
34x7	10.95	3.95
38x7	10.95	3.95
36x8	12.45	4.25
40x8	15.95	4.95

ALL OTHER TRUCK SIZES

SEND ONLY \$1.00 DEPOSIT

on each tire. (On each truck tire send a \$4 deposit.) We ship balance C. O. D. If you send full cash with order, deduct 5 per cent. We reserve the right to substitute brands when necessary.

MUTUAL TIRE CO., 1840 SOUTH MICHIGAN AVENUE Dept. 2027, CHICAGO, ILLINOIS

BIG HUSKY MUSCLES ONLY

America's Greatest Value

\$2.99
Complete Send No Money



WALL EXERCISER

AMAZING NEW 25 FEATURE
Home Gym Outfit and Training Course

You save over half on this amazing course of physical culture. Big Husky 10 Cable Muscle Builder Exerciser. 200 Lbs. Resistance (Adjustable). Two Heavy Duty Hand Grips for husky wrists and forearms. Wall Exerciser for back and shoulder development. Head Harness (adjustable) and Foot Gear. Rowing Machine Attachments. Regulation Heavy Ship Rope. The Great Shadow Boxer. Completely Illustrated Course "HOW TO GET STRONG". Hand Balancing Tricks. **FOODS EAT AND GROW STRONG.** Illustrated Secrets of Jiu-Jitsu. Famous Wrestling Holds. Regular Course "How To Get". Facts of Strength. Special Ways to Get Big Biceps. How to Strengthen Your Back. Muscle Gauge. Test Your Own Strength. Secrets of Chest Expansion. Stomach Muscles. New Power for Your Legs and Thighs. "For Men Only," facts you should know. Stirrup Exercises for Husky Legs. Special "30 Day Training Schedule" that tells you what to do each day. All This—For Only \$2.99. Act quickly before offer expires. Send your name and address. We'll ship everything out by return mail. Pay postman only \$2.99 plus postal charges. Outside U. S. cash with order.

ROWING MACHINE

30 DAY TRAINING

FOR MEN ONLY HOW TO GET STRONG

HERCULES EXERCISES
49 East 21st St. Dept. F-13
New York, N. Y. © I. P. D. Inc.

SHADOW BOXER



Sell to Stores
HANDLE REGULAR ROUTE

placing world's greatest line of Counter Card Merchandise with stores. Aspirin, Razor Blades, Dime-Lax, Bromo-Fliz, Confections. 100 fast selling displays. Over 100% profit for you and merchants. Steady repeat orders. No experience or investment needed to start. Big catalog FREE.

WORLD'S PRODUCTS CO.
Dept. 7845 Spencer, Ind.



REMINGTON PORTABLE

ONLY **10¢** A DAY

FREE TYPING COURSE

Buy this beautiful brand new Remington Portable No. 5 direct from the factory for only 10¢ a day! Standard 4-row keyboard, standard width carriage, margin release on keyboard, back spacer, automatic ribbon reverse—every essential feature found in standard typewriters! Carrying case and typing course free. Special 10-day free trial offer. You don't risk a cent! Write Remington Rand Inc., Dept. 108-6, 205 E. 42nd St., N. Y. C. Don't delay. Act NOW!



Every Second Wednesday

Every Month

15c



Ainslee's

Brings You

Smart Sophisticated

LOVE STORIES

Illustrated in the modern manner by leading artists

AT ALL NEWS STANDS

Make up to \$150 Weekly GIVING AWAY FREE RCA LICENSED RADIOS

RCA Licensed Automobile and Home Radio Sets for American, European and South American reception. Beautiful World Master floor model radios. Guaranteed foreign reception. Custom made with exquisite all matched walnut cabinet, aeroplane dial, twin illumination, dynamic speaker and automatic volume control. Given away absolutely FREE with our new sensational unique PUNCH SALES CARD PLAN. This is the opportunity of the year—make up to \$150 cash each week for yourself. Every home, car owner, store, office, factory, lodge, club or individual wants these marvelous new FREE RCA LICENSED RADIOS.

Write Today For Our New Starting Offers
Start at once making money with our unique sales plan. Write for full information how you can secure any or all of these plans.
DELUXE MFG. CO., Dept. 194, 173 W. Madison Street, CHICAGO, ILL.

WANTED MEN
MANAGE POTATO CHIP STORES



We furnish everything—help finance and locate you. No experience needed. Tremendous profits. Sensational introductory starting plan. No house-to-house canvassing. Wonderful opportunity. Rush name for free book of Profit Facts—today!

LONG-EAKINS COMPANY
640-8 High Street Springfield, Ohio

BE TALL Your Height Increased in 14 days or money back! Send 3c for Guarantee and Free Book of testimonials showing 3-5 inches gained. Or act now and obtain a valuable Health Course and "Success and Popularity" Course included free with guaranteed Height Increase System. Sent complete for \$2. **WRITE NOW TO:**

STEBBING SYSTEM
Dept. BG-3, FOREST HILLS, NEW YORK

PILES DON'T BE CUT Until You Try This Wonderful Treatment for pile suffering. If you have piles in any form write for a FREE sample of Page's Pile Tablets and you will bless the day that you read this. Write today. E. R. Page Co., 2315-T Page Bldg., Marshall, Mich.

TIRES MADE Puncture Proof as low as **40¢**

Make 48 \$6.85 AN HOUR
NO-FLATZ—sensational new discovery, ends flat tires forever! Just squirt it into tubes through valve stem and enjoy complete safety at any speed. No Flatz seals holes made by nails, rocks, glass, etc. airtight INSTANTLY and PERMANENTLY—increases life of tires and tubes. No more life-endangering punctures! No more ruined, rim-cut casings or torn, ruined tubes. No more puncture fixing cost! Takes only 5 minutes to make all tires puncture proof. Easy! Low priced! Guaranteed.

FREE SAMPLE —Men! This is a hot one! Auto fleet taxi and truck owners eager to buy. Big money for ambitious, live-wire distributors. Get in on ground floor. Write or wire for FREE SAMPLE OFFER and details.
NO FLATZ CO., Dept. K-51, CINCINNATI, OHIO



NO GENIUS NEEDED TO WRITE!

95% of all big pay writing jobs and profitable free lance writing work require no rare literary ability. Ordinary command of English and easily developed writing technique plus your own natural writing style may yield rich rewards. Many cub writers earning immediate money in spare time! Write today for big free book describing a new Simplified Training Course and Writing Clinic covering every branch of writing, short story, book, play, radio, news reporting, feature articles, advertising, publicity. Intelligent, friendly personal instruction and criticism. Costs less than average month at college. Deferred payments if desired. Also free scientific Aptitude Test which actually measures your writing ability. Send for both today. No obligation. No salesmen will call. Write now.

U. S. SCHOOL OF WRITING, Dept. F-2
20 W. 60th St., New York, N. Y.

Learn ELECTRICITY



IN 12 WEEKS—IN COYNE SHOPS
All practical work on real electrical machinery and equipment. No advanced education or experience needed. Lifetime employment help after graduation.

I'll Finance Your Training
Get your training first—then pay tuition later. Write today for all details of my "Pay-After-Graduation" plan and how many earn white learning.

H. LEWIS, PRESIDENT, COYNE ELECTRICAL SCHOOL
303 S. Paulina Street Dept. A5-45 Chicago, Illinois

HIGH POWERED TELESCOPE
GENUINE BROWNSCOPE AT AMAZING PRICES

Most powerful in America for the money!
16 power long range telescope. Can see moon's craters or time on pocket watch a block away. 5 sections. Approx. 3 ft. long. Fine lenses. Brass bound. Can be used as powerful microscope. **\$1.98**

Special Super Power 30X Telescope. Similar to above but more powerful. Guaranteed to see 900 times larger in face and 30 times closer. 31 mm. objective 4 powerful lenses. Large field. Includes powerful microscope feature. Only \$1.98 postpaid. **\$1.69**

BROWNSCOPE CO. Dept. 2 S 234 Fifth Ave., New York



BE AN AUTO EXPERT Learn AT HOME TO EARN BIG MONEY

Tired of layoffs and low pay? Send for FREE Auto Book of Big Pay opportunities in the World's Biggest Business, and facts about practical "Job Way" Training at home in your spare time for a Good Job with a real future. Learn how to make money quick. No previous experience or special education needed. Free Employment Service and Money-Back Agreement. Write TODAY To **MOTOR INSTITUTE OF AMERICA** 2140 Lawrence Ave., Dept. F-18, Chicago, Ill. **SEND FOR FREE AUTO BOOK**

U. S. GOVERNMENT JOBS!

START \$1260 to \$2100 Year

Steady Work
Many examinations coming.
Men—Women, 18 to 50

Mail Coupon today sure.

Franklin Institute, Dept. S 196, Rochester, N. Y.
Sirs: Rush to me without charge (1) 32-page book with list of U. S. Government steady jobs. (2) Tell me immediately how to get one of these jobs.

Name.....
Address.....

NEVER TOOK A LESSON FROM A TEACHER

—yet Bob is the envy of his music-loving friends

You, too, can learn to play any instrument this amazingly simple way. No expensive teacher. No tiresome exercises or practicing. You learn at home, in your spare time. Yet almost before you know it you are playing real tunes! Then watch the invitations roll in—see how popular you become. Yet the cost is only a few cents a day.



New Easy Method
You don't have to be "talented." You can't be too young or too old. No teacher to make you nervous. Course is thorough, rapid, simple as A-B-C. First you are told what to do—then a picture shows you how to do it—then you do it yourself and hear it. In a short time you become the envy of your friends, the life of every party.

LEARN TO PLAY BY NOTE
Piano, Violin, Guitar, Saxophone, Drum, Ukulele, Tenor Banjo, Hawaiian Guitar, Piano Accordion, Or Any Other Instrument

DEMONSTRATION LESSON FREE!

Send for free demonstration lesson, together with big free booklet which gives you details and proof that will astound you. No obligation. Write letter or postcard today. U. S. School of Music, 3588 Brunewick Bldg., New York City, N. Y.

Help Kidneys

Don't Take Drastic Drugs

You have nine million tiny tubes or filters in your kidneys which may be endangered by using drastic, irritating drugs. Be careful. If poorly functioning kidneys or bladder make you suffer from Getting Up Nights, Leg Pains, Nervousness, Stiffness, Burning, Smarting, Acidity, Neuralgia or Rheumatic Pains, Lumbago or Loss of Vitality, don't waste a minute. Try the Doctor's prescription called Cystex (pronounced Siss-tex). Formula in every package. Starts work in 15 minutes. Soothes and tones raw, irritated tissues. It is helping millions of sufferers and is guaranteed to fix you up to your satisfaction or money back on return of empty package. Cystex is only 75c at all druggists.

BIKE GIVEN

YOU can have this 1935 deluxe model motorbike without a cent of cost! Comes to you fully equipped. Speedy as a rocket! Also get 300 other big prizes—anything from a marble to a cooler wagon—and earn CASH, besides. This is not a contest, but a splendid opportunity to start a business of your own, delivering our 3 popular magazines in your neighborhood. Do it in your spare time. Will help you acquire valuable training that will be helpful in later life. Thousands of boys are earning MONEY and PRIZES. You can do it, too. It's easy. If you're between 12 and 16 yrs. old, write at once and we'll start you.

Jim Thayer, Dept. 514, The Crowell Publishing Co., Springfield, Ohio

NOW YOU CAN HAVE A NEW SKIN IN 3 DAYS' TIME!



GET THIS FREE

—and learn that what was considered impossible before—the removal of pimples, blackheads, freckles, tan, oily skin, large pores, wrinkles and other defects in the outer skin—can now be done harmlessly and economically at home in three days' time in many instances, as stated by legions of men and women, young and old. It is all explained in a new treatise called

"BEAUTIFUL NEW SKIN IN 3 DAYS"

which is being mailed absolutely free to readers of this magazine. So worry no more over your humiliating skin and complexion or signs of aging if your outer skin looks soiled and worn. Simply send your name and address and name the skin blemishes which trouble you most to MARVO BEAUTY LABORATORIES, Dept. 381-D, No. 1700 Broadway, New York, N. Y., and you will receive this new treatise by return mail in plain wrapper, postpaid and absolutely free. If pleased, tell your friends about it.

Prostate Sufferers



DR. W. D. SMITH
INVENTOR

An enlarged, inflamed or faulty Prostate Gland very often causes Lamback, Frequent Night Rising, Leg Pains, Pelvic Pains, Lost Vigor, Insomnia, etc. Many physicians endorse massage as a safe effective treatment. (See Reference Book of the Medical Sciences, Vol. VII, 3rd edition.) Use "PROSAGER," a new invention which enables any man to massage his Prostate Gland in the privacy of his home. It often brings relief with the first treatment and most help or it costs you nothing. No Drugs or Electricity.

FREE BOOKLET

EXPLAINS TRIAL OFFER. ADDRESS
MIDWEST PRODUCTS CO., B-300, KALAMAZOO, MICH.

Classified Advertising

Chemistry

BECOME A TRAINED CHEMIST! Earn big money! Equip your own laboratory. Supplies as low as 5c. Send 10c for informative catalogs. KemKit, 135 Johnson St., Brooklyn, N. Y.

Patents Secured

PATENTS—Reasonable terms. Book and advice free. L. F. Randolph, Dept. 513, Washington, D. C.

Detectives—Instructions

DETECTIVES EARN BIG MONEY. Work home or travel. DETECTIVE particulars free. Experience unnecessary. Write, GEORGE WAGONER, 2640-A Broadway, New York.

Old Money Wanted

OLD MONEY WANTED. \$5.00 to \$2500.00 each paid for old coins. Buying catalogue 10c. Bob Cohen, Muskogee, Okla.

JiuJitsu

JIUJITSU, BOXING, WRESTLING! Choose one! 10c covers instruction. Bennett Method, Suite 1102, 210 5th Ave., New York.

Photo Supplies

ROLL DEVELOPED, 8 Prints, Oil Painted Enlargement, also valuable coupon on beautiful 8x10 hand-painted enlargement. 25c. Quick service. Guaranteed work. Individual attention to each picture. Janesville Film Service, Dept. A58, Janesville, Wisconsin.

Male Help Wanted

LOCAL AGENTS wanted to wear and demonstrate Free Suits to friends. No canvassing. Up to \$12 in a day easy. Experience unnecessary. Valuable demonstrating equipment, actual samples Free. Progress Tailoring, Dept. T-352, 500 Throop, Chicago.

Stories

LET ME FIX up your stories so that they will have a chance to sell. I have written many stories for Street & Smith. For three dollars and postage I will revise a short story up to five thousand words long. I will give an opinion of a story of that length for only a dollar and the postage. I have had much experience and can give you valuable help. In writing to me be sure to include postage. Address John H. Whitson, Rowley, Massachusetts.

The Plane on the Cover

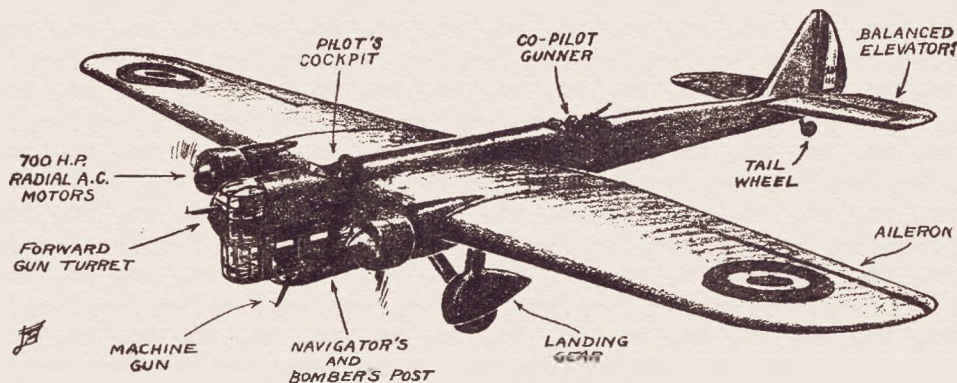

ALL EUROPE is arming! France has girdled her borders with concrete fortifications; England has doubled her air force and Germany is busy creating a mighty new military machine. In Paris, London and Berlin as well as in a score of smaller capitals, anti-aircraft emplacements are being prepared, bombproof cellars dug and gas-mask drills held. At the whine of an airplane engine, all eyes turn fearfully toward the sky and the dreaded words "air raid" tremble on every tongue. The painting on this month's cover shows the reason.

The Amiot 143-M is one of the new long-range, high-performance military planes designed for bombing raids. This big cantilever monoplane has a wing spread of over 80 feet, an over-all length of 58 feet, 8 inches and is almost 16 feet high. Powered with two 700 H. P. Gnome-Rhone K-Fourteens, this latest model of the Amiot carries over a ton of bombs 600 kilometers at a speed of 195 miles per hour. It is a flying fortress armed with machine guns.

In the nose of the ship is set a rotating turret in which the forward gunner is completely protected from the wind stream. Behind him, placed just ahead of the leading edge of the wing, is the pilot's cockpit. Aft of the wing, a second gun position guards the plane

against attack from above. Below the fuselage hangs a cabin somewhat resembling an airship car. In the forward end of this cabin are posted the navigator and bomber. They are surrounded by cameras, wireless equipment, etc., and are armed with a machine gun which points down through the belly of the car. Behind them, the center section under the wings is reserved for bomb stowage. In the rear of the car, still another gunner's post protects the underside of the ship from rear attack. All of these cockpits and compartments are, needless to say, intercommunicable during flight.

The picture shows a surprise night-bombing raid of the sort that is expected to usher in the next great European conflict. The big Amiot's are diving on the water front of a city, dropping their deadly eggs on naval bases, power houses and munition plants. The garrison has recovered from its surprise and as huge searchlights begin to finger the sky, the first shells from the defense batteries burst around the raiders.

When we consider that Paris, London and Berlin are closer to each other than New York is to Chicago, we should give thanks that our country is the good old U. S. A., with a great ocean on either side to protect us against such unpleasant surprises as shown on the cover.

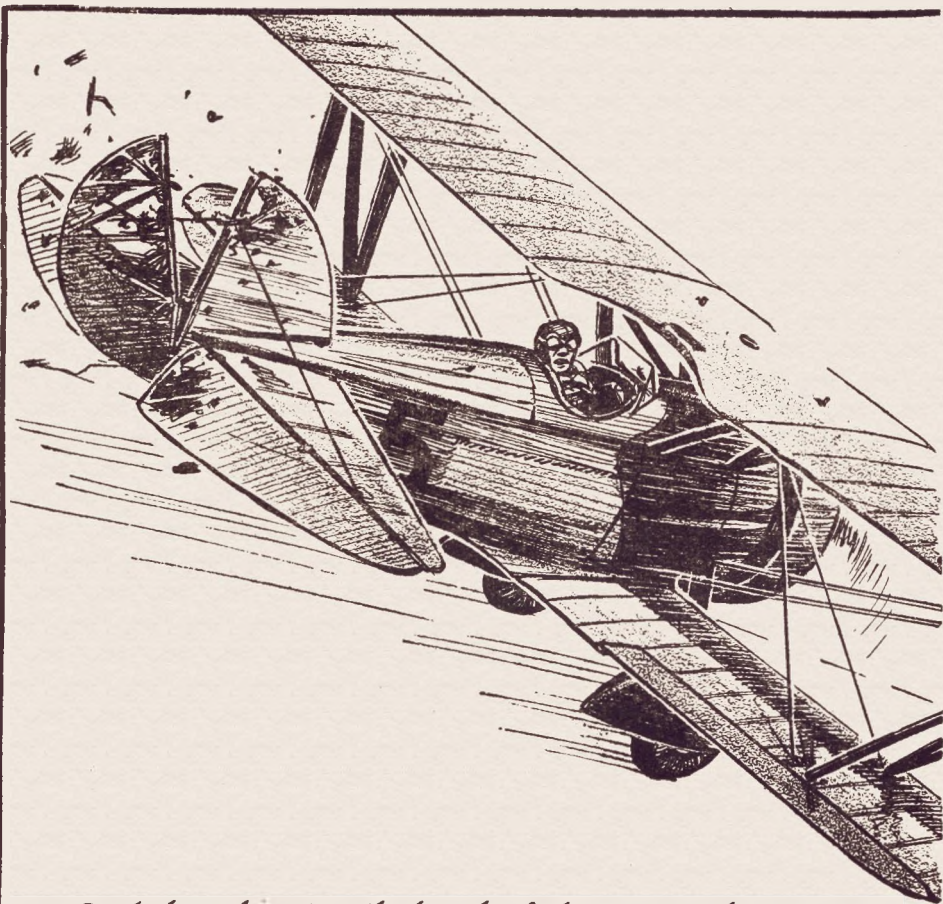

Sandy leaned against the breech of the one-pounder and bore down on the trigger. He saw a startled expression cross the enemy pilot's face. There was an explosion and the air ahead was clear. "Somebody," Bill spoke at Sandy's elbow, "is determined that we shall not reach Madagascar."

J.F.

WINGS OF THE JUNGLE

By

GEORGE L. EATON

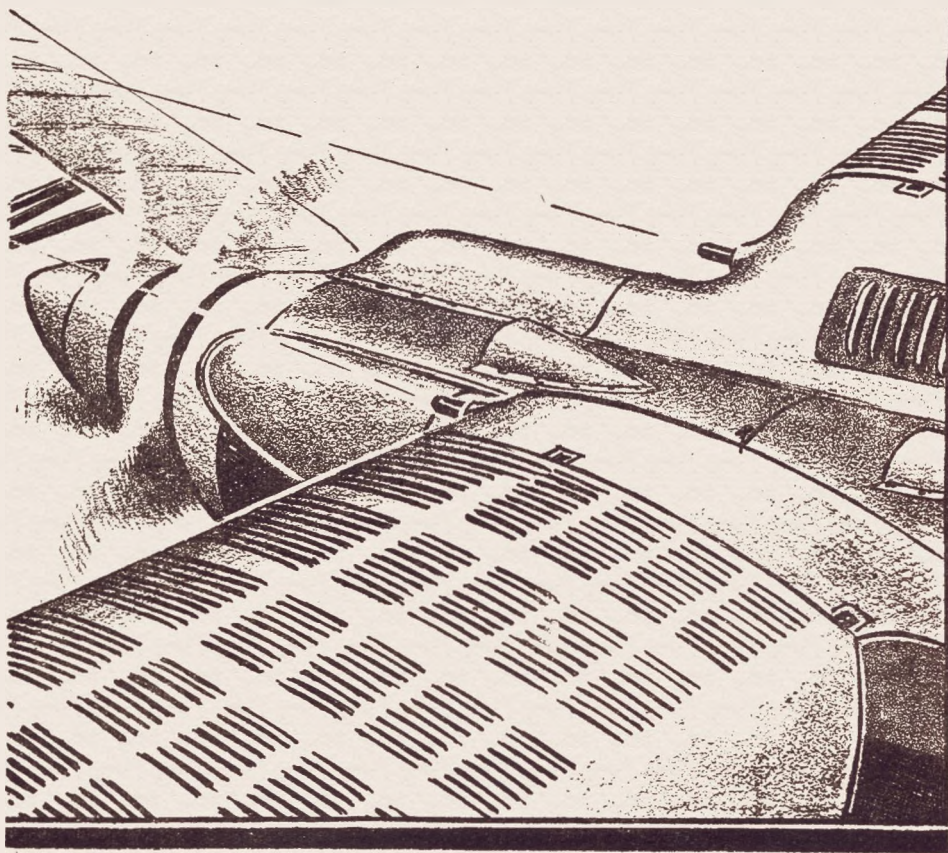

YOUNG "Shorty" Hassfurther was just twenty-one years old that sunny morning in the early part of 1918. He had been dubbed "Shorty" while he was learning acrobatics and aerial combat maneuvers at a war-time flying school in England. One of his classmates had remarked that he was built like an underslung automobile. Another one had suggested that he ought to sue Merry Old England because he was so short he bumped his elbows when he stepped over the curbstones. From that day on he was known as "Shorty."

But this morning in the early part of 1918 he was officially known as Lieutenant Gordon Hassfurther, pilot, United States Air Service, temporarily attached to Squadron 8-11, Royal Flying Corps. The fact that he had received word that morning that he was to be awarded a British decoration for having shot down his fifth German plane, and the fact that he was twenty-one gave him a feeling of austere superiority.

His remark to Major Virgil Wyndam, commanding Squadron 8-11, as they stood on the tarmac watching a green pilot bring in his ship indicated that he thought he was rather good.

"Look at that goof flatten out that S. E. 5," he said, with annoyance. "He ought to know he should be pretty well down on the ground before he flattens out. He'll pancake his front teeth through the instrument panel."

"What ho! What ho! The blighter'll wash out his undercarriage," Major Wyndam remarked. "A little bit of no good!"

The major was only a few years older than Shorty, but he had been flying pursuit ships on the western front for nearly three years. He and Shorty had struck up a real friendship during the past few months. They had, as the major expressed it, "wangled" their last two leaves together and he had taken Shorty home with him.

Those visits to the quiet little English

village where Wyndam's family lived and the tranquillity with which they accepted the War, had done a lot for Shorty. His family never mentioned the fact that two of Virgil's brothers had been killed in Flanders. They accepted it as part of the price they had to pay. There were no tears and no recriminations. They took it in their stride and hoped that Virgil would come home alive and sound.

The only time Shorty ever got an inkling of the way they really felt about things was when they spoke of Dick, Virgil's bright-eyed, ten-year-old brother. He was too young to join the colors, and they knew that the War couldn't last long enough for him to become of age. They philosophically accepted the fact that only Dick might be left.

Shorty was almost as fond of this red-cheeked English lad, Dick, as he was of his older brother. He liked the kid's deferential courtesy and quiet courage. And, no doubt, he liked his wide-eyed admiration.

The only thing Shorty didn't like about his major was his way of talking. He knew the major was a fighting, flying fool but he couldn't get used to his "pip-pips" and "what-hos" and general vague way of expressing himself. In other words he didn't quite understand the English he spoke.

The S. E. 5 pancaked out and bounced again and again. When it finally came to rest it had a bad list to port from a blown tire.

"What ho!" the major said, shaking his head sadly. "We'd better toddle, old onion, what?"

Shorty's blue eyes flashed and a grin spread over his Pennsylvania Dutch countenance.

"Toodle-oo!" he said and pulled on his helmet.

THE MAJOR and Shorty Hassfurther took their S. E. 5's off the field

of Squadron 8-11 in a long, low climb. At five thousand feet they tested their Vickers guns with short bursts of fire and the major signaled to Shorty to get some more air between his ship and the ground.

Their mission was to observe what the Germans were doing behind their own lines at a certain railway junction. Word had come back that they were massing troops for a surprise offensive. Headquarters wanted to know where and why.

Archies whooped below them, the smoke from their bursting shells spreading out like tiny clouds. They bored straight ahead paying little attention to the antiaircraft guns—avoided making too easy a target of themselves. They saw a formation of German Albatross planes far to the north of them. Shorty fingered his gun trips longingly. He had been concentrating on his guns recently. He had learned that a man could roll and loop and do Immelmann turns to perfection, but it would do him no good as a Hun hunter if he could not shoot straight. Young Major Wyndam had drummed a lot of things like that into his head.

He often smiled when he remembered the first impression Wyndam had made on him. In the first place he couldn't understand the way he talked, and in the second place he seemed to be trying to lose the War instead of win it. He had seemed so casual about it all.

But he changed his mind the first time he saw the major dive on a German plane, maneuver for position, let out a burst of fire and zoom upward. He hadn't even waited to see what had happened to the enemy plane. He knew!

Shorty had watched the plane plunge downward with a dead pilot at the controls. He feared no odds. Shorty had seen him attack a dozen German planes single-handed, shoot down the leader and fight off the rest one after another. When all his ammunition was gone he

zoomed upward into the clouds and disappeared.

He had taught Shorty the tactics of surprise, how to dive on the enemy out of the eye of the sun so that the dazzling sunlight blinded his foe. And how to steal up behind and just below an enemy plane so that he was "sitting on his tail" from where one straight burst of fire would send him plunging earthward.

The major and Shorty were flying tip to tip now. The war-butchered earth below them turned from a beaten, muddy brown to light-green as they got farther and farther behind the lines. A silver sliver that was a river wound in and out of the meadows. Men in greenish columns of fours were plodding toward the front on every road.

Suddenly the major pointed to fast-moving planes far below them. Shorty saw that they were German Fokkers. He counted the black-crossed wings. There were ten Fokkers flying in V formations of five each. The major pointed to the left and then at himself. Shorty nodded.

They flipped their tails into the air, opened their throttles wide and roared downward. They checked their Vickers guns and spare ammunition as they dove. The wind screamed through their struts and braces. The wires of their superstructures shrieked and whined.

Down and down they plunged holding their fire until the last minute when they would be sure of at least one victim each.

Shorty kicked his rudder slightly and eased over his stick. His eyes were mere slits in his taut, tense face. His mouth was a thin, straight line. He slid his hand forward to grasp his gun trips. His Vickers jabbared tongues of flame. Shoving his stick forward a trifle his tracers danced into the Hun cockpit. The pilot pitched forward over his controls and the plane plunged toward the earth.

Glancing over his shoulder Shorty

saw another German plane whirling downward in flames.

"At a boy, old pip-pip!" Shorty laughed and whipped his S. E. 5 back to the attack. He hurled his plane at a ship bearing the streamers of a German squadron commander. His guns belched forth another vicious burst of fire. The German plane faltered half out of control. Another burst sent it whirling downward, entirely out of control.

Only seconds had passed since their attack but three of the enemy planes were out of the fight. Shorty's eyes were gleaming now. He slashed his plane through the air with the wild abandon of a mad man as the other five enemy planes swung back to attack with their Spandaus spewing lead. The fury of their attack put the major and Shorty on the defensive. They rolled and zoomed and skidded to avoid the deadly fire that was turned on them.

As Shorty hurled his plane head-on toward a Fokker and tripped his guns he saw that the major was taking a terrific hammering from three planes. They were methodically darting in and out pounding him to pieces as he tried to get control of his wavering ship. Shorty gunned his engine and dove in between the three ships on the major's tail. More Fokkers joined the three while the major fought his controls.

THEN the whole sky became filled with slashing, snarling machine guns and planes. A formation of Bristol Fighters, English two-seaters, had seen the battle from above and had dived to the aid of the two S. E. 5's. It was the maddest, the wildest dog fight Shorty had ever seen. A German and a British plane crashed head-on and went fluttering to earth in a thousand pieces. The sky became a madhouse. Plane after plane went to earth in flames. Others crashed out of control with their pilots dead at the stick.

Shorty realized as he rolled and

skidded and dove to the major's aid that there were two black-winged Fokker D-7's riding his tail. As he started a wide turn to the left hoping to get on the tail of one of the planes with a series of Immelmann turns, the other one raked his S. E. 5 with a hail of lead. The bullets pounded through his wings and smashed against his instrument board. Splinters and glass cut his face. Blood ran into his eyes and down his face, half blinding him.

He threw his ship into a lazy spin hoping the two enemy pilots would believe he had been wounded and was falling out of control. But they continued to circle above him, following him toward earth.

As the chatter of a Vickers gun joined the roar of his own motor, and the two above him, he glanced up over his shoulder. He saw one of the Fokkers half roll to escape the major's fire. The major half rolled his S. E. 5 and got under the enemy's tail again. His guns stuttered their song of death.

Shorty flattened out his ship and zoomed upward after the other Fokker. As he got a bead on the black-winged German he damped down on his gun trips. As the same instant another plane flashed across his sights. How many bullets left his guns he never knew. But he checked his fire as he saw that the plane under his sights was the S. E. 5 of the major!

He saw the major's ship stagger and reel, and slide off on one wing. Shorty's face became ashen-white. He was trembling like an aspen leaf in a gale. Suppose he had got the major with that one short burst? The thought made him sick. He felt weak and dizzy as he pulled out of the fight.

He saw the major's ship stagger drunkenly toward earth. Suddenly, the whole sky seemed to explode near the major's ship. They were within range of German antiaircraft guns. Puffs of blue-and-white smoke appeared around

the major's plane. A shell burst within a few feet of him. Shrapnel cut his wings to ribbons and set his stays twanging. The undercarriage was shot away; canvas flapped in the wind; wires dangled as the ship nosed downward.

Shorty nosed his plane down, gunned his engine and went after him. He groaned as the major's ship skidded off to the right. He knew that the major was groggy and didn't realize that he was flying his ship deeper and deeper into enemy territory.

As Shorty whipped his plane around in front of the major's he waved his arms. The major was bending over the stick with a half-stupid stare on his face. His left shoulder was soaked with blood. His helmet and goggles were gone. His hair and forehead were a matted mess of red. Zooming, diving, cutting in so close he could almost reach out and touch the other plane Shorty tried to attract the major's attention to his direction.

The major refused to be driven from his chosen course. He maneuvered his plane to avoid crashing into Shorty but he paid no attention to him other than that.

Then the nose of his ship dropped. Shorty gasped with horror. He could never land safely with the undercarriage all shot away. But land he did. He brought his plane down as lightly as a duck alighting on water.

Shorty glanced up and over his shoulder and saw that they had left the snarling dog fight far behind. He decided that he would stick with the major and try to get him out of his plane and astraddle the empennage of his own and take him back home.

The major was sitting in the cockpit, barely conscious, when Shorty ran over to him. His eyes were glazed and his head rolled drunkenly from side to side. He stared at Shorty as though he had never seen him before. Then he smiled.

"What ho!" he said.

"Can you get out of there alone?" Shorty asked. "You're down in German territory."

"I'm a bloody sieve, old onion," the major said. "It's no go for the old Wyndam lad this time. I'm done up—all boned and rolled and ready for the oven."

"Shut up!" Shorty roared. He leaned over the side of the little ship and tried to lift the major. The major feebly pushed him away.

"It's no use, old bean," he protested. "I have my ticket west. Drop the jolly old family a note for me."

He raised one hand with painful effort and fumbled with the top of his flying suit. When he had it open he shoved a hand down inside his tunic and brought out a doubled sheaf of papers with an elastic band around them. He shoved them toward Shorty with a ghastly smile.

"Deed to that property in Madagascar we talked about. I think I won't be able to help you develop it after the War. Give you an idea what's what if you decide to go out there. Pip-pip, old egg!"

His chin dropped slowly. His eyes closed, like the eyes of a man exhausted. Shorty shook his arm frantically. He had to ask him one question before he died, if he was going to die. He had to know.

"Did any of my bullets get you, Virg?" he asked in a shrill voice. "Did I pot you when you cut across my sights?"

There was no answer. The major's arms hung straight down at his sides, his legs sprawled grotesquely.

Shorty knew his question would never be answered.

The major was dead.

SHORTY probed the sky above him as the sound of engines drummed overhead. Three German planes were cir-

cling to land beside his plane. He stuck the papers the major had given him in a pocket of his tunic and started toward his own ship. He knew he couldn't help the major now. The major was beyond all earthly aid.

And he knew that he must let all three of those planes get nearly to earth before he tried to get into the air himself. If they were above him when he took his ship into the air they would tear him to ribbons and pulp.

His motor was still ticking over slowly. He climbed into the cockpit after kicking the stone from under one of his wheels. As the first German touched his wheels to the ground and came speeding toward him he gave his engine the gun. The slow-moving propeller became an iridescent arc as the motor roared. He kicked his rudder and swung around into the wind. He missed the third German Albatross by a bare ten feet as he left the ground. The German pilot's face was white, his eyes wide and frightened as Shorty zoomed upward over his head.

Shorty climbed almost to his ceiling. His petrol was getting low. He might have to glide the last seven or eight miles.

And he was tired and shaken. He hadn't realized until now that he was utterly exhausted and not a little sick, both physically and mentally.

He couldn't believe that the major had really "gone west." Life wouldn't be the same without his cheery voice calling out his "pip-pips" and "what-hos." He knew that he would never forget that smile of the major's.

Then he was suddenly aware that there were three German scouts flying above him. For mile after mile he held a position directly beneath them expecting them to come tumbling on him at any minute.

When khaki figures in the trenches below told him that he was over allied territory he breathed a sigh of relief.

He searched the ground for a place to put his ship down if the three Germans above attacked him.

It was while he was gazing over the side of his cockpit that the three German Pfalz Triplanes dove on him, their guns streaming lead. Bullets ripped through his plane like a hot knife through butter. The stick was torn out of his hand as a bullet crashed through his shoulder. He ground his teeth together to throw off the terrible nausea that assailed him. He flopped his S. E. 5 into a trick, skidding turn and got one of the Germans under his hair sights. He raked the Pfalz with one vicious burst of fire and saw the plane plunge downward out of control. The others swooped down on him with their machine guns stuttering wickedly. Bits of his propeller flew off as they found the range. Lubricating oil spurted out of his engine crank case as a German bullet drove through it. Flames came streaming out a moment later.

He knew they would lick back to the wings and his petrol tank before he could get back to his own field.

"That," he gritted between his teeth, "will be the end of young Mr. Hass-further!"

He zoomed upward in a stall turn to escape the hail of lead drilling into the ship. For a moment he fought his controls. The ship leveled off. Then the nose came down. Reaching over he cut his engine and put the plane into a nose spin.

As it whirled dizzily toward earth the terrific rush of air blew out the flames that were creeping back to sear his hands and face. British anti-aircraft guns and machine guns from the nests in the tangled forest below him drove the two remaining Germans off his tail.

At the last possible moment he straightened out and skimmed the edge of the forest. The wind screamed and whined through his struts and wires. He leveled off close to the ground and

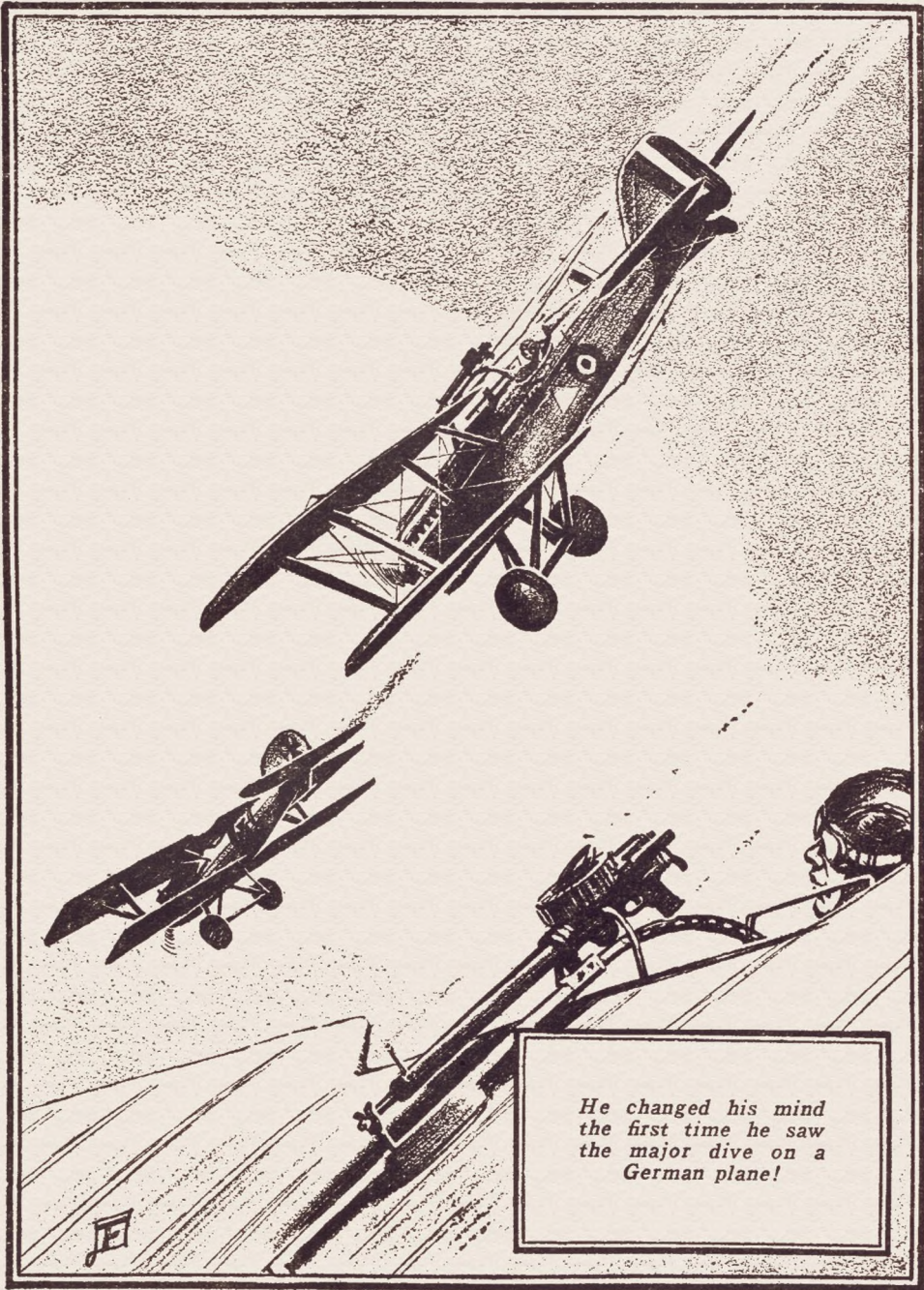

tapped his wheels lightly. The ship skimmed across the rough ground at a terrific speed. As it came to a halt young Shorty Hassfurther's head dropped forward on his chest. His hands fell to his sides.

But before he lost consciousness he remembered that last smile of the major's, before he died. He wondered if he was going to die—if this was the way death came to people.

He remembered that last smile as though it were painted on canvas. And he was to remember it again seventeen years later on the wind-swept plateaus of Madagascar!

II—OUT OF THE PAST

WHEN Shorty Hassfurther, chief of staff to Bill Barnes, opened the door of his room in the pilot's quarters on Barnes Field, that night in May, 1935, he was instantly aware that there was some one in the room. He closed the door softly behind him and crouched low while he moved toward the light switch.

Knowing the archvillany of the class of murderers and criminals who made up Bill Barnes' enemies, he was cautious. Barnes Field had been gassed, bombed and raked with machine-gun fire time and again. A Barnes pilot never knew but what death lurked just around the corner for him. The fact that Barnes and his men still lived was not due to any caprice of nature or good fortune. It was due to their inherent instinct for caution and their aptitude at taking advantage of the breaks which they, themselves, created.

Shorty's hair rose along the base of his skull as a high-pitched, unnatural voice cut the silence of the room. It was a voice such as he had never heard before. Eerie, blood-curdling. He remembered having heard a voice somewhat like it when he had been present at a spiritualistic séance one time. He

didn't have any faith in the fake voices of spiritualistic mediums. But he knew this voice was real because he was hearing it in his own room.

He wished he had a gun in his pocket. If he snapped on the light, whoever was there could shoot him down in cold blood before he could get to them. The words of the odd voice were more clear now. He listened, his hand on the light switch.

"This Shorty Hassfurther," the unnatural voice said, "is a punk and an oaf. He pinches babies and kicks cripples' crutches out from under them. He thinks he's a great flyer. But he's only a kiwi. If he ever got in a real air fight he'd stick his yellow tail between his legs and run for home!"

"You seem to know this fellow Hassfurther pretty well," another voice said, a voice that Shorty recognized.

That was when Shorty snapped on the light.

As the room was flooded Shorty glared at the freckle-faced kid who sat in his easiest chair, beside the table. On the kid's lap was a long-legged doll with a pot belly and a face that reminded Shorty of the faces of painted savages he had seen in Borneo.

"Up to your old tricks, eh?" Shorty growled. But the twinkle in his eyes belied his gruffness.

"Sandy" Sanders, the kid ace of Bill Barnes' world-famous collection of flyers, laughed. He threw back his blond head and laughed until the tears came to his eyes.

"How do you like my man Friday?" he asked.

"Get out of here before I throw you out," Shorty said.

The face and legs and mouth of the dummy on Sandy's knee began to move. It bowed its head and raised one arm with the aid of the strings Sandy had fastened to it.

"If there is any flat-footed kiwi around here who thinks he can throw

us out, let him hop to it," the gesticulating dummy said.

Shorty was across the room in two strides. But Sandy was too quick for him. He bounced out of his chair with astonishing agility. He opened the door and made ready to run as he worked the mouth of the dummy again.

"Good night, you kettle of Pennsylvania Dutch sauerkraut," the dummy said, with a bow.

Sandy Sanders got through the door a bare two inches before Shorty's foot swung toward his pants.

"Good night, sweetheart," Sandy called as Shorty slammed the door and laughingly leaned against it.

What would the kid be up to next? He had learned that trick of ventriloquism, Shorty remembered, just before the Bill Barnes expedition to Samerra. Now he was doing it with a stooge, or marionette on strings. Next he'd probably have a Punch and Judy show.

Shorty tore off his clothes while he tried to keep from going to sleep on his feet. He was certainly tired, he told himself. In fifteen minutes he was sleeping heavily.

THE ROOM was masked in darkness when Shorty awakened. There wasn't even the faintest rustle to disturb the abysmal stillness of the room. Yet Shorty was conscious of that same awareness that had possessed him earlier in the evening when he had come into the darkened room to find Sandy there. He moved his head slightly and saw that the illuminated dial of his traveling clock read four twenty.

He knew that something foreign to the room had caused him to awaken. His heart was beating faster than usual. His body was tense and damp with perspiration. Some inherent instinct warned him not to move, to pretend he was still asleep.

Suddenly, a spot of light played on the floor and moved toward the secre-

tary standing against the far wall. A hand delved into the pigeon hole from the darkness. Shorty gasped. The hand was long and slender like the hand of young Sandy.

It was Sandy up to another of his tricks. Shorty grinned and drew in his breath until his lungs were full. He let the air out with a shout that might have been heard at the other end of Long Island. Then he began to laugh. The flashlight went off and the room became dark again.

"Going to scare me again, kid?" Shorty asked.

There was no answer. "Get out of here or I'll break both your legs!" Shorty said impatiently and rolled to the other side of the bed to go back to sleep. It was fortunate for him that he moved.

He could feel the bed shake from the impact of the three bullets that crashed into the mattress where he had been lying as orange darts of flame spurted from a gun near the secretary.

Lashing out with both feet Shorty threw himself off the bed to the floor. With the same movement he slipped the automatic that nestled under his pillow into his hand. Lying perfectly still he listened for the slightest sound. His nerves were taut now.

He cursed himself for having mistaken the prowler in his room for young Sandy. He might have known it wouldn't be Sandy at that time in the morning. The kid was a nut over his hobbies but he wasn't nutty enough to get up at four o'clock in the morning.

This was some one who wanted something badly enough to attempt murder to get it. Cold sweat ran into his eyes as he conquered an almost overwhelming desire to wriggle across the room. He knew the man across the room was waiting for a move from him that would aid his aim when he fired again.

When Shorty could stand it no longer

he began to move forward. A button of his pajamas scraped the floor. He squeezed his body against the floor and waited. The absolute stillness of the room was terrific. It beat in his ears and left him weak and shaking. He edged forward a foot, two, three. Then a creak sounded in what he knew to be a corner. He flipped up his automatic and fired one shot, rolling quickly to the left as he fired.

A gun roared twice from the corner, the bullets thudding into the wall behind Shorty. He spread four more shots across the far side of the room and rolled back to the right.

The seconds stretched into minutes and hours, it seemed to Shorty, as he waited. Then he began to advance again. His hand came up against a wall. He began to circle the room inch by inch until he was near the door.

He slipped his hand up the wall and pushed the light button. As light flooded the room he dove for the protection of the bed. But what he saw in that one fleeting glance told him he had nothing more to fear. He got to his feet with his gun held in front of him.

A man was sprawled out in the middle of the floor. He was lying on his stomach and his arms and legs were spread wide. Blood was gushing out on the rug from a gaping hole in the back of his head.

"Got him in the face and it tore the back of his head out!" Shorty said in a horrified voice.

Voices sounded outside in the hallway. Some one beat on his door with heavy fists.

"Shorty!" Bill Barnes' voice came to him. "Open up, fella! Are you all right?" The fists continued to beat on the wood.

Shorty moved toward the door like a man in a trance. The hand that unlocked the snap lock was shaking. So was the one that still held his gun.

He opened the door and stared at Bill

Barnes as though he had never seen him before. Bill looked at his white, tense face and strode into the room. His breath hissed through his nostrils as he saw the thing lying on the floor. He looked from it to Shorty with wide, questioning eyes.

"Who is it, fella?"

Shorty shook his head as "Red" Gleason and Sandy Sanders pushed into the room followed by one of the Barnes



Heilner

Field guards and "Cy" Hawkins, another of Bill's pilots.

Bill dropped on one knee and grasped the man's wrist. Then pushed his hand in under his shirt. His blue eyes were narrowed, his bronzed face a trifle whiter when he looked up and shook his head.

"He's dead!" he said.

A torrent of questions suddenly leaped from Shorty's lips. He threw his automatic on the bed and sat down as he spoke.

"Who the devil is he? I woke up for some reason and got the idea there was some one in the room. I kept quiet until he put on a flashlight and began to rummage through my desk. I could only see his hand but I thought it was Sandy up to some of his deviltry. I shouted at him and he buried three bullets in my bed!" He pointed to the bed in evidence. "I grabbed my gun, and

rolled off on the deck. I got him a few minutes later when I heard him move."

Bill rolled the man over. There was a small, neat hole just between his eyes. He had been killed instantly.

"Any of you ever seen him before?" Bill asked.

There was a slow dissenting shake of the head from each of them. Shorty studied the man from every angle. Then he walked over to his secretary and examined the papers the man had pulled out of the pigeon holes. They were just bills and a collection of private correspondence. Nothing that would be of any value to any one but himself.

BILL was making a systematic search of the man's pockets without disturbing the body more than necessary. An exclamation burst from his lips as he held two sheets of paper toward Shorty.

"Here's a letter I found in his pocket that is addressed to you," he said.

Shorty took it and stared at it stupidly for a moment.

"Get Tony Lamport on the telephone and tell him to send Dr. Humphrey and a couple of men with a litter over here. And tell him to call the police," Bill said to Sandy.

Sandy dialed a number and spoke to Tony Lamport, the chief radio man on Barnes Field. When he hung up the phone Shorty was still staring at the letter.

Bill Barnes stood up and swept the room with his glance. Then, with his characteristic decisiveness, he spoke to Shorty again.

"Bring that letter along and come on over to my quarters for a few minutes before the police arrive. The rest of you had better stick here and see that nothing is touched until they come."

For once in his life young Sandy was silent as Shorty passed him. But he reached out his hand and gave him an encouraging pat on the shoulder. Shorty thanked him with a grin.

When Bill and Shorty were seated in Bill's rooms and Shorty had lighted a cigarette they both gazed at the letter Shorty still held in his hand.

"What's the tie-up between that letter and the man you shot?" Bill asked slowly.

"You tell me," Shorty answered. "It doesn't make sense. I can't link them up. You didn't find anything that would give you any idea as to the man's identity when you went through his clothes?"

"Nothing," Bill said. "Clean as a whistle. No identification on his clothes that I could find. Maybe the police'll have better luck. Who was that letter from?"

Shorty frowned and shook his head from side to side.

"It's from the father and mother of an old friend of mine. I meant to show it to you. It came this morning and I didn't have a chance to talk to you before I left for New York. I was puzzled by the letter. The son of the man who wrote it was my O. C. while I was attached to the Royal Flying Corps during the War. He was shot down during a battle behind the German lines. I was with him at the time. I had been home with him a couple of times on leave. We were great pals. But read it. That'll give you more of an idea. The 'Dick' mentioned in the letter was the younger brother of Virgil Wyndam, my O. C. I've visited them a couple of times since the War and we correspond at intervals."

A shadow of pain flickered in Shorty's eyes as he remembered Major Virgil Wyndam, his kid brother Dick and his father and mother. Seventeen years ago he had said good-by to the major.

Bill took the letter and read it.

DEAR SHORTY:

I hope we will not startle you, since so many months have lapsed between our letters. We have read in our English

papers of your exploits with Bill Barnes' famous squadron of fliers and are proud to be privileged to name you among our friends. Perhaps we should say "sons."

A curious thing has occurred. It prompts our asking you to delve back into your memory to help us solve a sorrow and mystery that seems almost more than we can bear in these, our last few years—I am much afraid that Mrs. Wyndam is not long for this world unless the thing is cleared up quickly.

As you know, conditions have been frightful all over the world. England has been no exception. Young Dick has had little success in finding a profitable enterprise since his graduation from Oxford.

After a great deal of pleading on his part we finally consented to his going to Madagascar as Virgil did before the War. He has had the idea in the back of his mind ever since he was ten years old, when Virgil told him stories of his life there.

We are sure that Virgil owned a large tract of land but we're unable to find any papers relating to it. Correspondence with officials on the island of Madagascar has netted us nothing. Dick wanted to go there to establish a claim to Virgil's land and then develop it.

After some discussion we financed the venture. Dick left, via steamer, from Marseilles for Tamatave, on the east coast of Madagascar several months ago. We heard from him regularly until he arrived there. Then, after one letter, we heard nothing more. He has vanished as though he had been swallowed up by the earth. We have used every means known to us to make some contact with him. Our foreign office has done everything possible. But they have not found Dick.

We have written to you because just before Virgil was killed in 1918 he wrote us that he had been talking to you about going back to Madagascar with him after the War. He wrote us that you had agreed to go. It occurred to us that he might have told you facts that he withheld from us about his property there—where it was located, etc.

We beseech you to probe your memory and give us any information you may recall, anything Virgil may have told you. Something that seems of small consequence to you may be the clue for which we are frantically searching, so leave nothing unsaid.

The loss of the last of our four brave sons seems more than we can bear. I beg of you, my son, to help us.

Sincerely,

THOMAS WYNDAM.

When Bill looked up from the letter his eyes were both misty and puzzled. He shook his head sadly. "War, and its aftermath, is a great thing," he said, sardonically.

"For whom?" Shorty asked, savagely.

"Can you give them any information about Virgil's land on Madagascar?" Bill asked.

"That's just it," Shorty answered, frowning. "We talked about going out there after the War. I was just a kid. It didn't make any difference to me where I went in those days."

"Or since," Bill said, dryly.

"I can't recall the details of the things the major told me," Shorty went on. "I can't remember names or places. I just remember that it was Madagascar. You see I got a couple through the shoulder that same day the major was killed. I also got a frightful thump on the head. Gave me concussion. I didn't know anything for days. Managed to land my crate, after it had caught fire in the air, behind the allied lines. Everything that happened that day has always been hazy in my mind. Sometimes little things come to me, but they seem like a dream—unreal."

"You can't link up this attack on you to-night with this letter?" Bill asked.

"Not even remotely," Shorty said. "Maybe the police will have some record of the man. That may help."

"I doubt it," Bill said. "It's deeper than that. After the police get through with you why don't you take a trip for a few days and see if you can't remember some of the things these people want to know. They seem to be in pretty bad shape."

"I know," Shorty said. "This kid Dick was all they had to live for. They lost two other sons beside Virgil in the

War. Dick——” His voice broke. He stopped speaking and turned away. “Let’s see if the police have come,” he said.

III—ALL FOR ONE

IT WAS late in the afternoon before the police commissioner, detectives, fingerprint experts, photographers and medical men finished in Shorty’s room. They found no clue to the identity of the man Shorty had killed. But they decided that he was German. Or of German descent.

“It’s a plain case of justifiable homicide,” the police commissioner said. “And like all the things that happen to you, Bill, the truth will come out later.”

“This is just the beginning,” Bill agreed. “Some one is gunning for us

again. They’ll show their hand before long. Then we’ll have something to work on.”

“I wish there was some way we could get advance notices on these cases of yours, Bill,” the commissioner said. “Then we could prevent some of the killings that usually occur.”

“That’s a big wish,” Bill said. “Killers seem a little prejudiced about keeping their murders a secret.”

The police commissioner snorted, shook hands with Bill, Shorty and Sandy and took his leave.

When he had gone Bill sat down and looked at Sandy long and searchingly.

“What’s this Shorty tells me about a savage-looking marionette and ventriloquism?” he asked the kid pilot.

Sandy squirmed uncomfortably and gave Shorty an accusing glance.

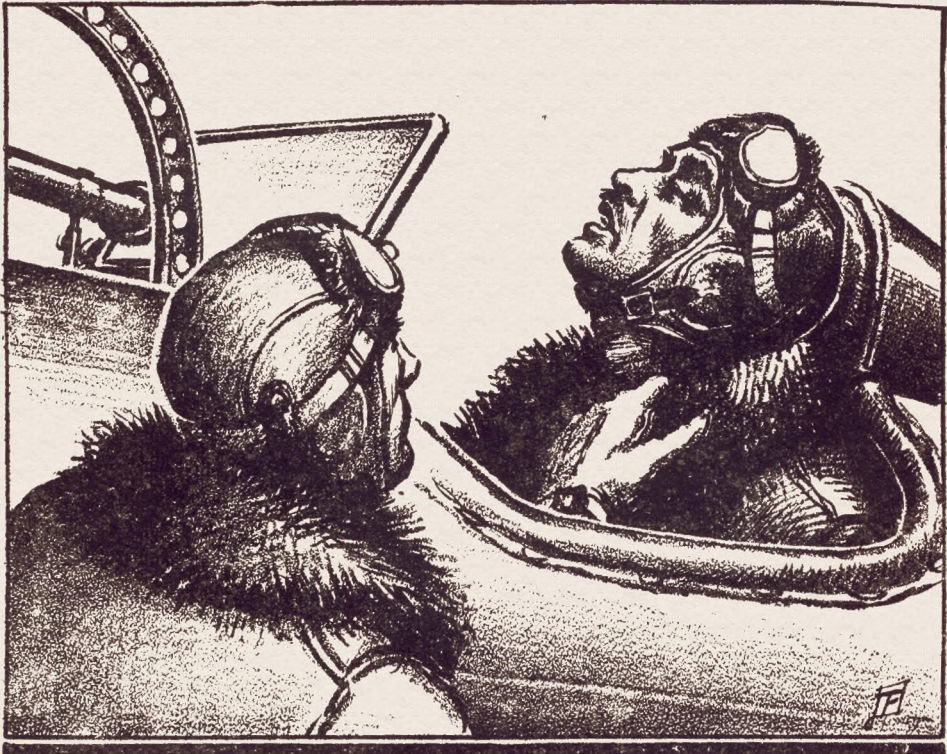

He raised one hand with a painful effort and fumbled with the top of his flying suit.

"Old Osiris himself." Shorty grinned. "The boy with the hidden voice—the boy with a lot of ideas and no sense!"

"Hupplecakes to you, fathead," Sandy said, indignantly. He turned to Bill. "I'm just practicing up on my ventriloquism again," he said. "Only this time I'm using a dummy."

"What for?" Bill asked.

"Oh, I'm just fooling around," Sandy said, coloring. "You know—like they do on the stage."

"He's going on the Orpheum circuit as a ventriloquist and sword swallower," Shorty said.

"And I'll take you along and exhibit you as the jackass that talks," Sandy said quickly. "Or the guy who won the War!"

Both Bill and Shorty threw back their heads and laughed. Sandy's face was crimson and his eyes were glittering with indignation.

"You win, kid!" Shorty said. "Pick up the marbles."

"Yeah, and you never won anything," Sandy said. He was mad now. Shorty always managed to get his goat without half trying. He got to his feet and went out the door slamming it behind him. Bill and Shorty continued to laugh.

"You'd better not ride him so hard," Bill said. "He might really get sore."

"He does get sore." Shorty grinned. "But it only lasts a few minutes. He'll be back soon and let me know in a roundabout way that he is sorry he got sore. He's a great kid."

They sat and thought about that for a moment. Then Shorty's thoughts flashed to young Dick Wyndam, the major's younger brother. He was older than Sandy now, of course. But they were not unlike. They were both fair-haired, fair-skinned and blue-eyed. His hands clenched when he thought how he would feel if young Sandy had disap-

peared as mysteriously as Dick Wyndam.

"I don't suppose you've thought of anything more about Madagascar," Bill said. "I mean, anything that will help the Wyndams?"

Shorty shook his head. "Not a thing," he said. "Perhaps something will come to me later on if I keep thinking about it."

A knock sounded on the door and Sandy's voice came from outside. "Oh Shorty!"

Shorty smiled at Bill and shouted, "Come in, kid."

Sandy pushed the door open, a shamefaced expression on his features. He grinned and sat down.

"I'm sorry about those cracks of mine about winning the War," he said to Shorty.

"Forget it, kid," Shorty said, grinning. Bill was trying to keep from laughing.

"And I was wondering if you'd show me the ribbons on a couple of your decorations," Sandy went on. "I've been collecting all the different ribbons of the countries in the War, and I wanted to check up on a couple."

Shorty opened a drawer in his secretary and pulled out a box. In it, reposing on a velvet lining, were eight or ten medals attached to ribbons. Sandy's eyes gleamed as he studied them.

"Gosh!" he said. "What did you get this one for, Shorty? It's a V. C. isn't it?"

"Yeah," Shorty said. "They gave it to me for swimming the Thames River in my night shirt."

"Nuts!" Sandy exclaimed. "Which one did you get first?"

"The Croix de Guerre," Shorty said. "I lost the medal, but I have a ribbon on an old tunic." He crossed the room and opened a closet door. After poking around for a few minutes he brought out an old khaki tunic that was blood-

stained and tattered. Above the top left-hand pocket was embroidered a pair of silver wings. Attached to the tunic was a short bar with the green-and-red ribbon of the Croix de Guerre."

Sandy took the tunic and gazed at the bullet holes and blood stains with reverent eyes.

"I suppose they gave you this with your lunch one day," Sandy said, pointing to the ribbon.

"For being able to eat snails," Shorty said, solemnly.

Getting to his feet Bill ambled toward the door.

"When you're through with your hero worship I want to see you, Sandy," he said before going out into the hall.

As Bill closed the door behind him, a curious expression suddenly came over Shorty's face. Sandy stared at him in amazement as he snatched the tunic from his hands. Shorty's face became white and his hands trembled as he tugged at a button on the left, top pocket.

"If it's still there——" He jabbed his hand in the pocket and withdrew it. In his hand was a little sheaf of stained papers. He dropped the tunic on the floor and spread the papers out on his secretary.

Beads of perspiration were standing out on his forehead now. Sandy watched him in amazed silence, hardly breathing.

As Shorty unfolded a crudely drawn map an exclamation escaped him. He waved the map and another paper that was printed in French under Sandy's nose.

"There's the secret!" he shouted. "I stuck those papers in there seventeen years ago, kid. It all comes back to me now. The major gave 'em to me behind the German lines, just before he died."

"What does——" Sandy was suddenly speechless.

"Find Bill and bring him back here, kid!" Shorty roared. "Tell him I've found some papers about Madagascar."

SHORTY sat down and gazed at the bloodstained papers as one might gaze at a friend who has returned from the land of the dead. A thousand thoughts flashed through his mind. And a thousand memories.

That flight over the German lines in 1918 became vivid as it had never been before. He could see the havoc the War had wrought on the torn earth below him. Bodies of men and beasts decomposing between the lines. Oceans of mud and filth and destruction.

He thought of the old battle crates they had flown in those days—planes a man would not trust in 1935. Spads, Nieuports, S. E. 5's, Bristol Fighters, giant Handley-Page bombers, Albattrosses, Pfalz "tripes," Fokkers. They all marched before his eyes like a parade of ghosts.

Brave men had flown them. Mostly men like the major—mere kids who were not afraid of death. Kids who snapped their fingers in the face of death and died as they had lived. Gloriously!

He shuddered as he thought of that battle the morning the major had died. He closed his eyes as he saw the major's S. E. 5 come under his own guns. That vision had haunted him all his life. He had never been sure that his bullets had not done for Wyndam. It was not his fault. But that hadn't made it any easier.

That little bundle of papers brought the whole thing back to him with sickening clarity. If he had remembered those papers perhaps young Dick Wyndam wouldn't be among the missing now.

And why had that man taken the letter, from the major's father and mother, that morning? What was the connection between the dead German and the Wyndams?

It came to him that he must find out about those things. Was Virgil Wyndam still alive? No. That couldn't be true because the Germans had dropped notice of his death. It was something else. He got up and began to pace back and forth across his room.

He stopped when Bill came into the room. But he had made his decision.

"Sandy said——" Bill stopped as Shorty pointed at the papers on his desk. They both bent over them.

There was a crudely drawn map of Madagascar with markings that showed where Virgil Wyndam's property was located. There was a deed to several thousand hectares of land in Virgil Wyndam's name and a half dozen other papers showing the location of the minerals on the land.

"It looks," Bill said, "as though he had everything from gold to potash on the property. Does this stuff bring anything to mind you couldn't remember before?"

"Everything," Shorty said quietly. "They bring back a lot of things I didn't want to remember. Everything he told me about the place is written in his notes."

"Anything that makes a link between the man who tried to kill you last night and the Wyndams?"

"No," Shorty said. "That's still a mystery to me. But I've got to solve it, Bill." He stopped talking and walked to a window and gazed out on Barnes Field for a couple of minutes. When he turned back to look at Bill his face was hard and set.

"I've got to leave you, Bill," he said. "There's no other way. I've got to know what this is all about."

"Leave me!" Bill said. "You mean leave the organization?"

"That's what I mean, Bill," Shorty said, evenly. "I've got to know. Those papers bring back memories that have haunted me ever since the War. I've got to know."

Bill gazed at Shorty with an expression beyond description.

"You can't do that, Shorty," Bill said. "Why, I wouldn't know how to get along without you. Why, I—I——" No words came to him that would adequately describe his consternation. He made funny grasping motions with his fingers. Shorty's face was lined and haggard now. He shook his head.

"I've got to go, Bill," he said. "You see, Wyndam saved my life that morning. I'd never have got home alive either if it hadn't been for him. And I've always had the idea that perhaps I killed him. I had a couple of Huns on my tail and he drove 'em off. When I got one under my sights I started to let him have it just as the major came across my guns. He had to land a few minutes later, and he died before I found out whether my bullets had got him."

"He gave me these papers that morning, before he died. If I hadn't forgotten them perhaps young Dick wouldn't have disappeared. I don't know why he disappeared or how but I've got to find out. I feel responsible in a way. I've got to square my own conscience. I don't know what I'll find but I'm going to Madagascar. The major's father and mother were almost like my own father and mother. They're both dying with broken hearts. It's up to me to do what I can."

Bill Barnes didn't say anything for a moment. He turned the things Shorty had said over and over in his mind. He understood the way Shorty felt about the thing. Yet, he didn't see what Shorty could do. But this isn't the kind of thing you stop to reason out, he thought. It's one of those things where you do what you think you ought to do.

Suddenly, he stuck his hand out. And he was smiling in a way that Shorty understood.

"All right, fella," he said. "You're going. But so am I! We'll go over

there and rip this thing wide open. I know how you feel and I'm glad you feel that way. The rest of the gang will feel the same way. If you won't stick with us we'll stick with you."

They shook hands. Shorty protested against Bill's decision.

"It will cost a small fortune to take the whole crowd," he said. "And it may cost a few lives. It's my fight, Bill. I don't want you to mess in it. It may be just a wild goose chase. You never knew these people. They don't mean anything to you."

"You knew 'em," Bill said, simply. "That's enough for me."

"But Bill——"

"Listen!" Bill said. "You know Sandy's favorite expression? Nuts! Well, that's what I say to you. If you're in this thing we're all in it! That's what this organization is for. If we can go out and take a chance on getting our heads shot off for other people we can do it for ourselves. Now shut up!" Bill's eyes were flashing. He was pacing back and forth across the room with long, powerful strides.

"All right, old Richard the Lion Hearted." Shorty grinned. "We'll put on our go-away pants and hop for Madagascar. It'll give us a chance to christen the new carrier-transport. And who knows——"

"Hotcha!" Sandy's voice said from the doorway. "I was just looking the place up in the encyclopedia. It says they have a man-eating tree there." His eyes were gleaming, his freckled nose screwed up.

Shorty had an impulse to make a wisecrack, but he just slapped Sandy on the back so hard that Sandy staggered.

"If it hadn't been for your nosey interest in medals I'd never have found those papers," he said.

"I'm a valuable guy to have around." Sandy beamed modestly.

IV—NARROW ESCAPE

WITHIN AN HOUR Barnes Field became a place of feverish activity. "Scotty" MacCloskey, the chief engineer, and Martin, the master mechanic, worked their perspiring men at top speed checking over the gigantic carrier-transport, two Snorters and Bill's Scarlet Stormer.

A dozen mechanics and half as many sheet-metal men were busy making minor adjustments and repairs on the sleek-looking ships. Bill Barnes stood beside the monster bomber and transport, dressed in high-topped boots and breeches. His light, flannel shirt was open at the neck. His hair was tousled and his blue eyes were shining with pride as they ran over the big ship he had designed and had constructed in his own factory at Barnes Field. What a beauty she was!

Her sixteen-foot props gleamed dully in the glare of electric lights as a mechanic blasted the two fifteen-hundred horse power, supercharged Diesel engines.

Above and behind the mechanic in the pilot's seat was a circular platform on which was mounted one of the new, rapid-firing one-pounders that could throw one hundred one-inch shells in the space of a minute.

In the midships section of the transport was the hangar of the Eaglet, Sandy's fast little fighter. Suspended by its landing hook from an overhead girder, the latest Eaglet was locked rigidly in place on the girders, and hung with its cockpit just above the level of the deck.

Behind the Eaglet's hangar was a retractable machine-gun turret that could be lowered below the bottom of the fuselage. Farther down on the port side were two lavatories, with shower stalls and wash basins.

On the starboard side was Bill's private cabin with his own private bath. A

guest cabin was just to the rear. In a large compartment that extended across the full width of the deck was a dining saloon and the living room of the crew,

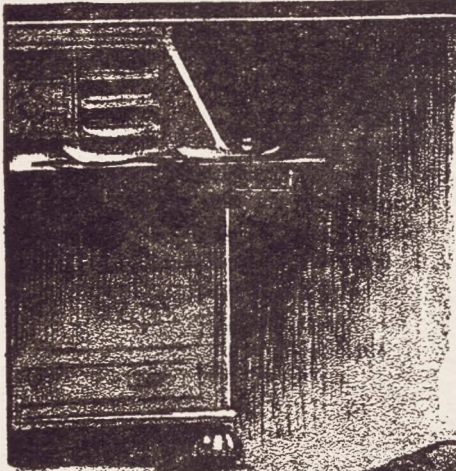

flectors gave the pilot and co-pilot excellent visibility.

Steps led downward from the bridge and pilot's compartment to a machine-gunner's cockpit in the nose mounted with a .50-caliber gun. Beneath his feet were the bomb sights and releases. In each of the wings, abaft the engine were inclosed machine-gunners' pits similar to the one in the nose. A runway connected these two cockpits with the main fuselage enabling the two gunners stationed there to go back and forth while the plane was in flight.

"She's a sweet thing, lad," old Scotty MacClosky said, his words thick with his Scotch bur.

"She'll do," Bill said. "You're check-



with a folding table and twin divans that could be made into bunks at night.

An electric stove and refrigerator in the galley aft graced the workroom of old Charlie, the cook, and machine-gunner of the tail cockpit.

On the bridge of the monster ship were dual controls and instruments, a Sperry automatic pilot under the pilot's seat, wireless equipment, a new Kreusi radio compass and a "homing device." An arrangement of built-in metal re-

Shorty got to his feet with the gun in front of him. A man was sprawled out on the floor.

ing the equipment on all four planes—ammunition and emergency equipment?”

“Everything’s shipshape, Bill.”

“The motors are all right? You know we’ll have some long hops. Bermuda, the Canary Islands, across the top of Africa to Cairo and down the Red Sea to Djibouti and Zanzibar, and Tamatave on Madagascar. Algeria is no place to have a motor conk on you.”

Old Scotty turned a wounded countenance toward Bill. His long face and brown eyes were laughably sad.

“Have I ever let you go out of here without your motors being O. K., lad?” he asked with the air of one who has been unjustly accused.

“Not yet.” Bill laughed. “Have Tony Lamport make the arrangements for refueling.”

“You’re leaving at dawn?”

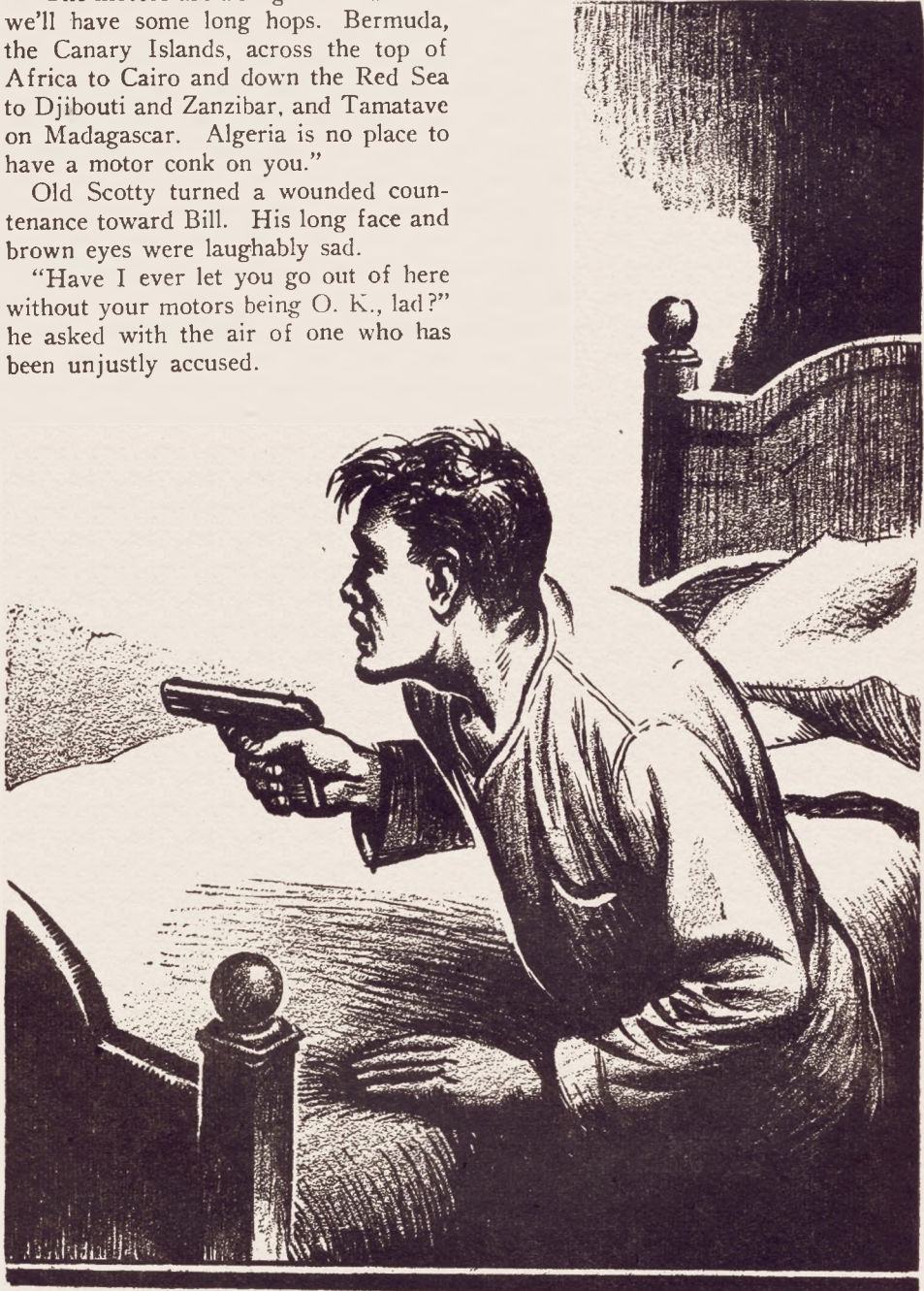

"At dawn," Bill said. "The weather reports seem to be all right. Looks as though we will have a tail wind to Bermuda. You had better——" Bill's lips froze; his eyes stared as he saw a figure stagger through a small door in the front of the hangar and slip to the concrete floor. He ran across the hangar bellowing with rage as he saw that Red Gleason's face and head were covered with blood. Dropping on one knee he lifted Red's battered face. Red tried to speak but no sound came from his lips. He pointed a wavering hand toward the field outside as an airplane motor roared on the apron.

"They came in with a dead stick and landed down the field—two of 'em," Red gasped. "Jumped Shorty in his room. They're taking him with them. Knocked me cold. Go get 'em, Bill." His eyes closed as a groan of anguish escaped his lips.

Bill eased Red into Scotty's arms and rose to his feet. He bellowed orders at the top of his voice. A bell rang in the hangar and the enormous door slid back on its runners. Mechanics swarmed around a sleek, twelve-hundred-horsepower Snorter that had already been warmed up. As it rolled out on the apron Bill Barnes leaped for the forward cockpit.

"Sandy!" he bellowed, "get another Snorter into the air. We'll have to force that ship down." A stocky, rugged, cabin biplane was just lifting its nose off the concrete runway at the far end of the field as the motor of Bill's Snorter blasted.

He kicked the ship around in a half turn and started down the runway into the wind with his flaps set well down. After an incredibly short run he lifted the ship into the air and began to spiral upward. The fast little cabin plane was boring through the air a half mile away as he flipped a switch on his radio panel and shouted Sandy's name into the microphone. He could see Sandy's

Snorter speeding down the runway and taking the air as Sandy answered.

"We've got to move fast, kid," Bill said. "It will be dark before long and we'll lose him. You stay right on his tail. Ride his tail on his blind spot, and I'll get some feet under me and dive on him to force him down. Don't hit the plane if you have to use your gun. You may hit Shorty. We'll drive him down. Got it?"

"O. K., Bill," Sandy said. "I'll ride his shirt off."

Bill's eyes were two spots of fire as he scanned his instrument panel. The gray biplane was streaking along five thousand feet below him. Sandy was riding its tail, just below and behind it.

With an explosive curse Bill shoved his control column forward and blasted the Snorter into a power dive. His speed was terrific and mounting higher. The wind howled and screamed and whined as he tripped the triggers of his two machine guns. White death streamers cut a path in front of the biplane. Bill knew his speed was too great for accurate shooting. But he didn't care about accurate shooting. He wanted the pilot of that gray plane to know he was not alone.

THE GRAY PLANE went into a sweeping turn as Bill leveled off and whipped back into a chandelle. The pilot of the gray plane had seen Sandy and was maneuvering to get in position to use his guns. But each time it seemed that he would have Sandy under his guns the kid whipped around in a series of Immelmann turns that broke his aim.

Bill was back in the battle now, riding just above the biplane. The pilot tried desperately to outmaneuver the two Snorters. He was being forced lower and lower by their frequent bursts of machine-gun fire. They could see his white, strained face as they flashed by him. Suddenly, Sandy dove straight

across his gun sights to lure him lower. As the enemy pilot dove on Sandy, Bill came down on his tail and forced him even lower.

The long, rolling country of Westchester was under them now. Bill decided that here was a likely place to force the man to land. He knew they might injure or even kill Shorty, but he had to take that chance. They would probably do worse than kill him if they got him off alone and tried to make him talk. He was probably lying bound and helpless in the back of the biplane. Bill's blood seethed through his body as the thought came to him that Shorty might already be dead.

Sandy was still flaming back and forth across the sky with the enemy pilot trying desperately to use his guns effectively. The pilot of the biplane could handle his ship. His desperation had added to his skill. He was whipping his snarling plane through the air like a madman.

Bill fired burst after burst just over the top of the swirling plane. Suddenly the ship stuck its nose toward the earth in a terrific dive. A golf course spread out directly below him. Bill groaned as he saw the biplane diving closer and closer to the earth. Sandy was riding almost on its tail.

Then the rugged gray ship flattened out. Its nose came up. It was only a hundred feet from the ground. Bill's mouth opened wide and a roar escaped him as he saw the wings of the ship fold back against the sides of the fuselage. The ship seemed to whirl around like a circular disk. Its nose went down again and it plummeted toward the ground.

Smoke and dirt shot high in the air as the plane struck the ground and half buried its nose in the green fairway of the golf course. Smoke came billowing back from the engine housing as Bill set his Snorter down, kicked his rudder and taxied as close to the ship as he

dared. He was over the side of his cockpit in one leap and running toward the plane as Sandy rushed in from the other side. Flames were beginning to lick back along the fuselage as Bill ripped open a bent door. He stuck his head into the suffocating cabin. Smoke and flame were coming back through the twisted instrument board. The pilot and the man beside him were smashed beyond recognition. Their bodies sprawled grotesquely across the two forward seats.

Behind the one seat in the rear Bill could see a dim form lying on the floor. He called Shorty's name and received no answer. He pulled the rear seat toward him and got hold of Shorty's bound feet.

Gently and carefully, as though he had all the time in the world, he pulled Shorty toward him. He lifted him over the two mutilated bodies in the front seats and passed him to Sandy.

Carrying Shorty between them they half staggered from the gray plane that had now become a fiery furnace. When they were barely fifty feet away the fuel tanks of the biplane exploded. Gusts of hot air and flame seemed to take the very skin off their faces.

Another fifty feet and they put Shorty down on the ground. As they bent over him his eyes fluttered open and closed again.

"Are you all right, fella?" Bill asked, his voice tight and unnatural. Shorty's eyes came open again. He stared at them for a moment with glassy eyes. Then the semblance of a weak smile flashed on his lips.

"I'm a tough guy," he said. "Who hit me?"

His gaze wandered to the burning plane. He looked at Bill questioningly.

"Some one—two men—went in your room, blackjacked Red and you. They left Red, but tried to take you away in that plane over there. We drove them down and they crashed. Are you hurt?"

"I don't think so. My head feels as though they had dropped a safe on it. Outside of that I'm all right. What did they want? What was the big idea?"

"Those papers," Bill said, quickly. "Do you still have them?"

Shorty produced a real grin this time.

"Sure," he said. "I had Tony Lamport put them away in your safe. I'm going to have copies made of them. There is something darned funny about all this, Bill. Those papers must be worth a lot of money or men wouldn't go around trying to murder to get them."

"Those babies over there will never try to murder any one else," Sandy said.

"Can you walk?" Bill asked.

"I can try," Shorty said. He got to his feet unsteadily, with their aid.

"We'll stick you in the after cockpit of my Snorter," Bill said. "We've got a lot of things to do before dawn." He stopped and looked at Shorty keenly.

"Maybe we'd better put this thing off for a few days. I mean, our start. Our first leg is to Bermuda. Then the Canary Islands. It's going to be tough going."

"What do you think I am," Shorty asked. "A lily?"

Bill grinned as he helped Shorty over the side.

"All right, fella," he said. "We shove at dawn, if the doctor says you're O. K."

V—MORE MYSTERY

CY HAWKINS, the slow-talking, fast-thinking Texan, stood with Bill Barnes on the apron just before dawn the next morning. Bill was giving last-minute instructions to Scotty MacCloskey before the four ships took the air.

"Don't let Tony Lamport forget about making plans for our refueling at Bedmuda, the Canary Islands, Cairo,

Djibouti, Zanzibar and Tamatave," Bill said.

"You're sure Red and Shorty are all right?" Scotty asked, anxiously. "You have some long hops ahead of you."

"They're too tough to be bothered by a couple of raps on the head," Cy said. "Anyway, try and keep 'em home."

The props of the two Snorters, the Scarlet Stormer, and the monster transport were ticking over slowly. The goggled, white-helmeted heads of Bill's men jutted above the rim of the scarlet amphibians. They were waiting impatiently for Bill to signal the dispatch tower. Luggage, ammunition and emergency equipment in the tails of the big ships had been carefully checked.

"You're in charge, Scotty," Bill said. "Bev Bates will be back in a couple of days to give you a hand. I'll keep in touch with you by radiophone when the weather isn't too soupy. By cable when it is."

Cy shook hands with Scotty and moved toward his Snorter.

"This," Bill thought, "is one of the most mysterious expeditions I've ever undertaken. I don't know where or why." He shook his head angrily. He shook hands with Scotty MacCloskey and raised his hand above his head. The dispatch tower acknowledged.

The motor of Red Gleason's Snorter roared. A signal flashed. The Snorter rolled forward as the brakes were released. Red Gleason grinned and began to sing as his ship streaked down the runway. The tail came up. The concrete faded away beneath it. Red took it swiftly upward in tight spirals. At five thousand feet he leveled off and began swinging around in wide circles until Cy had joined him in the other Snorter.

As the twenty-four-hundred-horsepower engines of the Scarlet Stormer blasted, Shorty Hassfurther flipped a hand of farewell into the air. His flaps came down and the wheels of the long,

streamlined pontoons left the concrete. The amphibian gear rose smoothly to disappear beneath the fuselage. The Scarlet Stormer joined the circling Snorters overhead as Bill climbed into the starboard pilot's seat of the transport-carrier.

Bill slipped his boots into the rudder stirrups and gunned the twin, super-charged engines. He flipped a switch on the intercockpit telephone and checked his crew. Old Charlie, the



cook; Miles, who operated the landing and loading trapeze of the little Eaglet and the retractable machine-gun turret; Martin up in the nose, who could knock a fly off an apple tree with his bombs at two hundred m. p. h.; McCoy and Neely in the two machine-gun cockpits abaft the engines. Straight-shooting boys, all of them. They could take it. And sometimes had to!

On the circular platform above and behind Bill's head sat young Sandy Sanders. Before him was the rapid-fire, one-inch gun that could throw a hundred shells a minute, mounted on a circular glass-inclosed turret. From his seat he could see into the pilot house and into the Eaglet's hangar. He was riding forty feet above the ground as Bill threw the brakes on the monster ship.

Bill's lips were a thin, grim line across his face and the knuckles of his hands were white on the control wheel as the big transport rolled down the concrete with ponderous grace. The low-winged monster left the concrete almost immediately as the flaps came down. Bill took it upward in wide, sweeping spirals.

The four ships fell into a tight formation with the Snorters just a little behind and on each side of the transport. Two thousand feet above and a little in front rode the Scarlet Stormer with Shorty's hand wrapped around the control column.

As the four ships stuck their noses on the horizon and took a course south by east, Shorty had a moment of uncertainty. His face clouded and he shook his head slowly from side to side. Suddenly, he flipped the switch on his radio panel and spoke Bill's name.

"Bill speaking, guy," came back to him.

"Listen, Bill," Shorty said, earnestly. "It's not too late to turn back, even now. I haven't any idea what is ahead of us. We don't know why any one wanted those papers. Or who wanted them. We don't know anything about it. It's twice as bad as flying blind."

Bill gave a snort of derision.

"Who wants to turn back?" he asked. "We usually make out, don't we?"

"Sure, Bill. But——"

"But, my eye! Judging by the cable you had from Wyndam after you cabled we were going, we'll do a lot if we can turn up the disappearance of young Dick. It will mean life or death to them, probably. It may mean a fortune besides. But we don't know that yet. We'll take things as they come. And keep your powder dry! If it's worth a trip from Madagascar to New York to steal those papers, they must be valuable. The birds who want them will probably come shooting next time."

"I learned to keep my powder dry

when I was twenty years old," Shorty said.

"Then why don't you get dry behind the ears?" young Sandy said into his microphone above Bill's head.

"Shut up, you long-legged brat!" Shorty answered. "I'll check back later, Bill."

BELOW THEM the newly cleaned Statue of Liberty held her torch pointing skyward. The waters of the East and Hudson Rivers joined in the harbor of New York. Barges and battleships, tugs and tramps, steamers and ferry boats made their way through the heavy harbor traffic, their whistles and sirens shrilling. Little antlike forms that were men poured out of the ground on their way to their every-day life in the towering skyscrapers on the lower end of the island that was Manhattan.

Black smoke curled above the industrial towns of New Jersey as they hurtled above them. The Atlantic Ocean shimmered under the morning sun and curved away.

A solid mass of cumulus clouds came racing toward them as the State of Delaware spread out beneath the speeding formation.

Skirting the eastern shore of Maryland they fled above the choppy waves of the Chesapeake Bay and into Virginia. This was all old territory to Bill. He had flown it hundreds of times. The formation was flying blind now, checking their position with Bill every five minutes. Off Cape Hatteras Bill checked his bearings carefully and altered their course almost due east.

The drone of the powerful Diesel motors filtered back through the sound-proof construction of the big duralumin ship. The monotony of the drone brought a yawn to Bill's lips. He shook his head and decided to give the controls to Sandy while he took a look around to be sure everything was as it

should be. If he didn't he would go to sleep.

He looked back and up to where Sandy was riding in the circular, one-pounder turret above his head. What he saw caused his eyes to pop.

Sandy was sitting with a gangling dummy on his lap. The dummy had a belly like a department-store Santa Claus and a head covered with kinky, black hair. The features were picked out with white paint so that the face had the appearance of a death's head. The thing was bowing and waving its arms as Sandy manipulated the strings attached to them. Bill grinned and strained his ears to hear what the thing was saying in that high, piping voice.

"Red Gleason and Shorty Hassfurth-er?" it was saying. "Why, of course I know them. After they lost their jobs as street cleaners they were stable boys for my uncle. My uncle gave them the gate because it made the horses sick to look at 'em."

Bill saw that Sandy had the dummy talking into his microphone. He turned on his own radiophone to see if Red and Shorty were listening to Sandy. They were. He grinned as he listened to the cracks coming back at Sandy.

"I understand they are fliers now," Sandy said to the dummy.

"Fliers?" the curious voice of the dummy replied. "Drug-store fliers, you mean. They're so dumb they think an outside loop is something you attach to your radio and hang out the window. Shorty told me he was going to the zoo the other day. I asked him why. He said he wanted to see one of those wild animals they had just captured—an amphibian!" Sandy threw back his head and laughed in the best stage fashion.

"I understand you do a little singing on occasions?" he said to the dummy.

"Oh yes," the dummy replied. "I sing very well. That guy with the flat ears, Red Gleason, thinks he can sing,

too. I'll sing you a little song I made up about Red."

"Hey!" Bill yelled into the microphone. "Where do you think you are, half-wit? How about coming down here and taking over the controls?"

"O. K., Bill. O. K.," Sandy replied, hastily. "I was just amusing the hired help to keep awake."

"You'd better get some sense and keep your eyes open," Bill said. "It looks as though we might hit some soupy weather."

"Nothing's going to happen on this trip," Sandy said, dismally. "It's going to be one of those long, tedious journeys."

A roar of laughter sounded over the microphone from Shorty. Then he lifted his voice and spoke in a high falsetto.

"Deah! Deah! I do find these long tedious journeys so tiring. So hard on the complexion and the nerves. My doctah told me to find some new interests to relieve my boredom. Fawncy seein' you heah!"

"Nuts to you, you fish-faced ape!" Sandy shouted.

BILL BARNES threw the controls of the monster transport to Sandy and went down the steps to the runway alongside the Eaglet. He stuck his head in his own compartment for a moment. His eyes were shining with pride as he peered into his own private bath. The carrier-transport was certainly a success.

He went aft into the tail and talked with old Charlie for a moment. As he stuck his head in the door old Charlie quickly closed the door of the electric oven. He closed it so quickly Bill looked at him suspiciously. Old Charlie rubbed his big hands on his apron and grinned foolishly.

"What are you cooking?" Bill asked. "It smells good." He stuck a hand out to open the oven door.

Charlie grasped his arm quickly to stop him. "Don't open the door. It'll spoil," he said.

"What'll spoil?"

Old Charlie looked at his feet like a schoolboy caught in the act of hitting his teacher with a pea shooter.

"It's just a pie," he said.

"A chocolate pie!" Bill said. His face was stern, but there was a twinkle in his eyes. "You know you're not supposed to carry stuff for pies on a long cruise, Charlie."

"I know it, sir," Charlie said. "But Sandy brought it aboard. He said he probably wouldn't get anything to eat in Madagascar. He said he had to have one chocolate pie."

Bill threw up his hands and stalked out of the galley, slamming the door behind him. But he was grinning. Try and keep food away from that kid, he thought.

Sandy held the ship steady on her course while he studied the complicated instrument board. He saw that a slight tail wind had brought their cruising speed up to two hundred and ten miles an hour. Everything was ticking over beautifully.

He flipped the switch on the radio panel as a red light burned more brightly. A voice chanted into his ear phones:

"Calling B. B. Calling B. B. Calling B. B.," it said.

"B. B. answering," Sandy said. "B. B. answering, Tony."

"That you, Bill?"

"Sandy speaking."

"O. K., kid. Tony from the field. Get Bill on the phone."

Bill connected his ear phones a few seconds later and spoke to Tony. Tony's voice was more than a little excited. His words tumbled over one another.

"We picked up a bird in Shorty's room," Tony reported. "He was going through the place with a fine-tooth

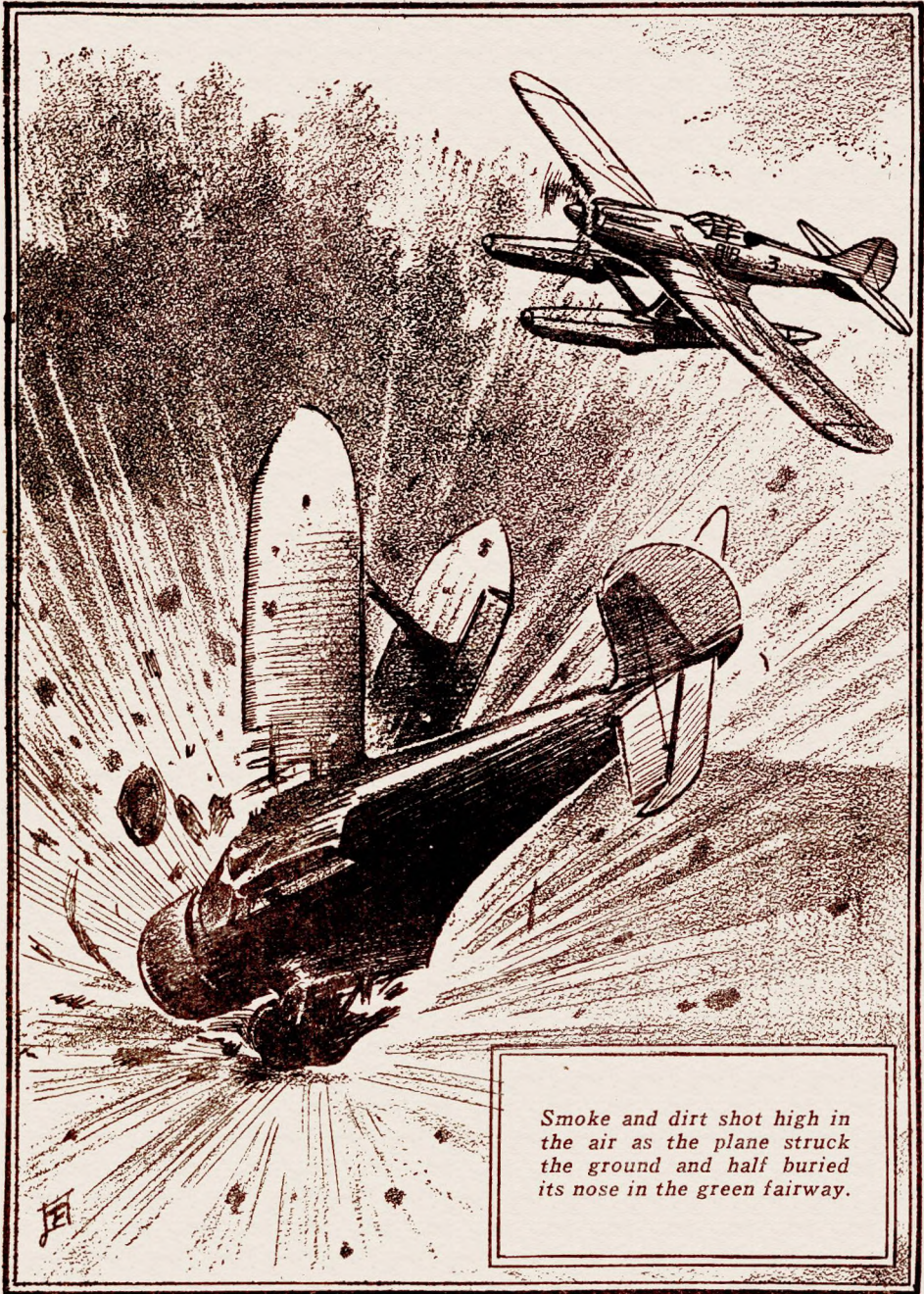

Smoke and dirt shot high in the air as the plane struck the ground and half buried its nose in the green fairway.

comb. His name is Belcher. Scotty signed him on as a mechanic a couple of weeks ago. A good man and a hard worker, Scotty says. We've tried to get him to talk, but he won't. He has closed up like a clam. We checked his references and credentials and found they were forged."

"Could you find any papers among his things that would give you an idea as to where he came from. Or from whom?"

"Not a thing, Bill. Clean as a whistle. Nothing on him when we caught him. What'll we do with him?"

"Turn him over to the commissioner of police and tell him I want him held," Bill ordered. "Tell him to hold him on some pretext or charge until he hears from me again."

"Right, Bill. How's the transport riding?"

"Sweet," Bill said. "Tell Scotty she's a honey."

"O. K., Bill. Everything has been arranged for refueling and supplies along your route. Keep us informed."

"Right, Tony. Signing off. I'll check back from Bermuda."

VI—PLANS FOR REVENGE

TWO MEN sat at a small metal table in a sidewalk cafe on the main street of the hill city of Tananarivo, the capital of Madagascar. They were both large men with large bones and large paunches. Their hair was blond and their eyes were a cold, metallic blue. Their features were large, hard and cruel.

They watched the milling throng of natives and Frenchmen passing their table with disinterested eyes. They did not see the Frenchmen who passed them now. Their minds had flitted back over a period of seventeen years and they were seeing other Frenchmen. Frenchmen who plodded along the shell-torn roads of their own country, their

backs laden with all their earthly possessions. Frenchmen fleeing from the advancing German hordes. Frenchmen in uniform, fighting desperately to withstand the onrushing and victorious Germans.

Through the minds of these two Germans ran a kaleidoscopic picture. The pictures raised from fighting on the ground to battle high above the clouds. They saw themselves as youths of twenty-four or five piloting their Albatross planes through a shell-torn sky. They saw a mad, frantic dog fight in the air between British and German fighters. They saw men fall dead over their control sticks and plunge to the earth in flames. They saw a British S. E. 5 limp to earth, mortally wounded, and another one land beside it. All this came back to them from the past.

All these things flitted through their minds. They remembered how joyful they had been when peace had been declared. And how sorrowful and bitter they had been when they learned the terms of that peace. A peace, they believed, that had robbed Germany of her possessions and colonies unfairly.

And in their twisted, youthful minds a desire for revenge had been born. They bided their time and studied how best they might help their country to regain its place in the sun.

In 1928, when Germany had been sucked dry and nothing remained in prospect for them at home they made their way to Madagascar.

They recalled that their plans had been hazy in those days. They had an idea—a deep, sinister idea. And they set about putting it in motion—

Adolph Boettner brought his huge fist down on the table with a bang that caused the bottles of imported German beer to dance. His face was twisted in a snarl of purple anger. The blood vessels bulged on his high Teutonic forehead.

"Inefficiency!" he growled in Ger-

man. "Belcher cables that dunderhead Kurtz got himself killed trying to locate the papers. Now he cables that Hortsmann and Kiel got themselves shot out of the air by this fellow Barnes when they tried to kidnap Hassfurter!"

"If the fools had planned right they would have succeeded," agreed Hans Zimmerman. "These half-baked kids of to-day do not know the meaning of the word efficiency as we knew it in our youth. They do not know how to withstand hardships or act on their own initiative." He drank deeply from his seidel and wiped his mouth with the back of his hand. His narrow, pig eyes were alive with contempt and derision.

"We must do something," Boettner said. "We have trained an army of natives and they are waiting for us to put the descendant of their queen back on the throne so that they can throw off the yoke of France."

Zimmerman chuckled deep down in his chest, a noise that rolled out of his mouth to keep time with his bobbing stomach.

"Your niece," Zimmerman said, with a curious light in his eyes, "will make a charming queen, although she is a little too fair to play the part of a Malagasy."

Adolph Boettner's face became purple again. He pointed a finger at his friend. His eyes were mere slits in his face.

"You get the idea of my niece out of your head!" he roared. "I brought her out here to play the part of the granddaughter of the queen the French exiled. And you are not to be the king! You get such ideas out of your head!"

Zimmerman shrugged his shoulders and picked up his seidel again. All that can wait, he thought. We will see who will be king.

"Let's not fight among ourselves," he

said, suavely. "The thing we have to do is put Cistra on the throne and drive out the French. With the weapons we have smuggled in and the men we have trained it should not be hard. Once we have a foothold we will have"—he lowered his voice to a whisper—"powerful weapons and money behind us. The French will not dare to attack us if we can take the island, using the natives as a smoke screen.

"But now the French are suspicious of us. Their secret service is working on us constantly. They know we are up to something. They know we have massed the Hovas and Sakalavas and other natives behind us. They have investigated the deeds to our property carefully. They think there is a fly in the ointment, but they aren't sure. If they knew we had bribed men to falsify the tax records and commit forgery they would slit our throats and throw us to the crocodiles."

"As we slit the throats of the men we bribed," Boettner growled.

"Such men are better dead," Zimmerman said calmly.

"But what are we going to do now?" Boettner asked. "We must get the records straight until we have our army thoroughly trained. With this fellow Barnes and his men on their way here anything might happen. They must know something. Hassfurter must have remembered something vitally important to start them off on a fifteen-thousand-mile journey."

"Hassfurter remembers what his major told him seventeen years ago," Zimmerman said. "His major's parents have written to him about the disappearance of their youngest son. We know that. Barnes is up to his old tricks. Sticking his nose in other people's business."

"When he sticks his nose in this business he'll get it bent," Boettner said. "When he gets here I'll slit the pig of a Yankee's throat myself."

"He mustn't get here," Zimmerman said. "He must be stopped."

"How?"

"Easy!" Zimmerman said. "We have ten fighting planes, fully armed and almost ready for delivery. Heilner and his men will be ready to leave Europe with them any day. We will cable Heilner to follow the course of this fellow Barnes and his men. Heilner will take care of them. When Barnes finds himself pitted against an old War flier like Heilner he will find

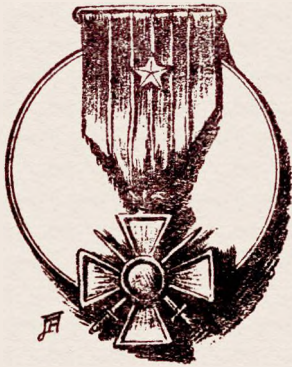

it is a different matter than being thrown against the slobs they are training nowadays."

Boettner shook his head from side to side. His eyes were shining with admiration.

"Trust Hans to think of a way," he said. "Heilner will knock him out of the air with one hand while he eats his lunch!"

"If Heilner is as good as he was in 1918 he won't need either hand," Zimmerman smiled. Suddenly the smile disappeared from his face and it became hard and cruel and treacherous. He pointed his finger at Boettner.

"You remember that Hans always thinks of a way," he said, his eyes threatening. "We all agreed that I was always to be in command. Don't lose sight of that. We will all get along better—and live longer if we keep that in mind."

Fear crept into Boettner's eyes for a moment as he gazed into the merciless eyes of Zimmerman. A hundred thoughts flashed through his mind. Thoughts that had to do with his niece and Zimmerman's attentions to her. They had brought her to Madagascar to impersonate the descendant of the last queen. The gullible natives had believed their story and were ready to fight to regain the island that had belonged to their fathers and grandfathers. Now Zimmerman was hinting at making himself the king after Boettner's niece was on the throne. Then, Boettner knew, Zimmerman would get rid of him and would have to share his gains only with Heilner—until he got rid of Heilner. He decided that he would talk to Heilner after Heilner had got rid of Bill Barnes.

"I am keeping it in mind," he said, placably. "I am always keeping it in mind."

"That is better," Zimmerman said, hitching his chair closer. "Now, Belcher cabled that Barnes is on his way to Bermuda and is going to cross to the Canary Islands. From there he will take his men over lower Algeria. That is the place for Heilner to strike. There will be no one but a few Arabs to see Barnes' men wiped out. If they are shot down and live they will never get back to civilization. They will be fortunate if they are not horribly tortured."

"We had better get cables off to Heilner immediately," Boettner said.

"After," Zimmerman said, rubbing his hands across his fat stomach, "I have another bottle of beer."

FRITZ HEILNER, veteran pilot of the Imperial German Air Force, read the decoded cablegram he held in his hand and chuckled evilly.

So, he thought, that over-exploited Yankee, Bill Barnes, is going to mix in other people's business again.

"I," he said to himself, "will teach him the tricks the Red Knight over Germany taught me. Only Barnes will not live to profit by the privilege. And Hassfurther! Seventeen years I have waited to get another chance at him."

Heilner was thinking of the morning Shorty Hassfurther had nearly taken his head off getting off the bumpy ground behind the German lines. Heilner's hideously scarred face attested to the fact that some one beside Shorty had tried to take his head off. The some one had been a French anti-aircraft shell that exploded nearly in his face. One of his eyes was of glass. The whole side of his face had been reconstructed but showed horrible scars. The flying helmet he perpetually wore hid the jagged tears where hair should have been. With a hump on his back he would have been the personification of the hunchback Victor Hugo so aptly described. Murder and violence and evil were written on his frightful face.

He tore the cablegram into a hundred pieces and threw it to the winds. He turned and ran an expert eye over the ten gray biplanes lined up in the hangar. They were rugged little single-seaters with short, flat wings, lean fuselages, stripped-down undercarriages, and mighty power plants. Mechanics and gunners were swarming over them adding the last touches to the installation of their twin machine guns.

Heilner smiled to himself as he thought how he had hoodwinked the English manufacturer of the planes into building them ready for machine-gun installation and synchronization through the prop. After the ships had been completed he and his men had flown them across the English Channel to a little country in northern Europe. There, under the strictest secrecy, the machine guns had been installed. They would be ready for tests before the day was over. With their breath-taking speed and ability to climb to twenty

thousand feet in six minutes they would be the equal of any fighting plane in the world.

Heilner had read of Bill Barnes' Scarlet Stormer. But he did not believe the things he had read and heard about it. To him the reports were like all the reports that came from America. All bluff and noise and braggadocio, with no performance. He shouted at the stocky German who was supervising the work on the ten fighters.

"Have all planes tested and refueled and ready to take off at dawn to-morrow morning, Beck," he ordered.

"Where——" Beck stopped.

Heilner looked at him from his one good eye.

"Never mind where," he said. "Have them ready. No leave for any pilot to-night."

"Yes, sir!" Beck answered, saluted smartly and turned away.

VII—SEVEN TO ONE

BILL BARNES gazed numbly at the light burning red on the radio panel before him. His eyes were red-rimmed and tired. He had stayed at the controls most of the time during the flight from Bermuda and he was weary. An unannounced storm had buffeted the big ship about like a feather.

Shorty had brought the Scarlet Stormer through. Cy and Red had taken a terrific beating riding the storm in their sturdy amphibians. But they had won the fight. Now they were all anxiously scanning the horizon ahead for the first of the Canary Islands.

Bill glanced at young Sandy, sleeping in the co-pilot's seat, as he threw over the switch on the radiophone.

Shorty's voice sounded in his ears. It was high-pitched and excited.

"Land, fella!" Shorty shouted. "Dead ahead. And I'm almost dead. I can sleep for a week. I didn't know they

brewed storms like that one in this locality."

"The weather men do it," Bill said, grinning. "They do it to get even with the guys who complain about their service."

"They're even," Shorty answered. "How long do we lay over here?"

"Until late to-morrow afternoon," Bill answered. "Then we'll miss some of the heat over the Igidi Desert if we make the hop to Cairo at night."

But Bill Barnes and his men did not make an overnight stop on the Canary Islands. After landing they found that the condition of one of the fifteen-hundred horse power Diesel motors in the monster transport required certain replacements—replacements they were not carrying with them.

After a talk with Tony Lamport on Barnes Field over the radiophone, and an hour's conference, Bill decided they must push on for Oran, one of the three settled departments of Northern Algeria. There, according to Tony Lamport, they would be able to secure the replacements necessary.

The five weary pilots lifted the noses of their ships into the air at two o'clock in the afternoon. In an hour they were high above the dark-blue mountains of Morocco, mountains dotted with white-domed tops.

Over the endless barren wastes of the Oasis Tafilet they altered their course north-northeast until the sparkling Mediterranean flashed beneath them. Flying low they could see the green meadows beyond hedges of pale-lavender asphodels, fields of orange-hued buttercups, pale-yellow daisies and masses of apple and pear trees in full bloom. Far to the south of them they could see the white tops of the Sahara Atlas Mountains and far to the east the dim outline of the snow range of the grand Kabylia blocking the horizon.

Fishtailing onto the field at Oran at

dusk they were greeted by a Frenchman who spoke excellent English. He had been notified of their coming and informed Bill that they could supply him with the parts needed, also oil and petrol for the Diesels.

"That's a break, fella," Bill said to Shorty. "I was afraid we might have to send for Bev Bates to bring the things we need."

"Sure!" said Shorty. "But let's go some place and get to bed."

"Just a drooping pansy," Sandy said, blinking his red-rimmed eyes. He added: "Just a guy who can't take it!"

"I learned how to take when I used to win the six-day bicycle races without a partner," Shorty replied. "But you wouldn't know about that. It was before you were born."

"All right, grandpa," Sandy said. "Comb the curls out of your beard and we'll help you to the hotel."

"Shut up!" Bill roared. He turned back to the smiling French official to find out if it would be necessary to leave a guard with his planes.

"No danger," the suave Frenchman assured him. "They will be well guarded."

"I'll be out early in the morning, with my men, to work on the transport," Bill said.

Five minutes later Sandy's eyes were popping as he gazed out of the car window at barbaric-looking spahis, blue-and-yellow tirailleurs, pale-blue chasseurs d'Afrique and the red-and-blue uniformed Zouaves from the army of Africa and Foreign Legion station at near by Sidi bel Abbes.

"It is just as well we had our trouble before we tried to cross the desert and mountains," Bill remarked. "We can hop from here along the coast of the Mediterranean to Algiers, Tunis, Tripoli and down to Cairo. Ought to do it in about twelve hours if we don't have trouble. I like it better this way. Cross-

ing the Sahara at this time of year is no set-up. The sirocco is blowing."

"What's the sirocco?" Sandy asked.

"A south wind off the Sahara," Bill said. "It's called the sirocco or simoom. It drives them crazy in Italy—blows continuously until they are all exhausted."

"It wouldn't be any place for Shorty," Sandy said. "He'd be tired in half an hour."

But after a hasty dinner in the *sâle-à-manger* of their hotel Sandy was the first one to crawl into his massive bed with mountainous feather covers. Five

minutes later he was doing outside loops in his dreams.

While Bill and Shorty went over their maps and charts and weather reports Cy and Red Gleason wandered out into the street where the "fête Mosambique" was in progress. Attended by the discordant noises and loud smells of an Arab gathering, the heat, dust, dirt and dogs were more than they could stand.

"Right, Bill," Sandy said. His voice was cool and calm now. For a brief instant a gray plane came under his sights. The breach of the one-pounder burned against his cheek.

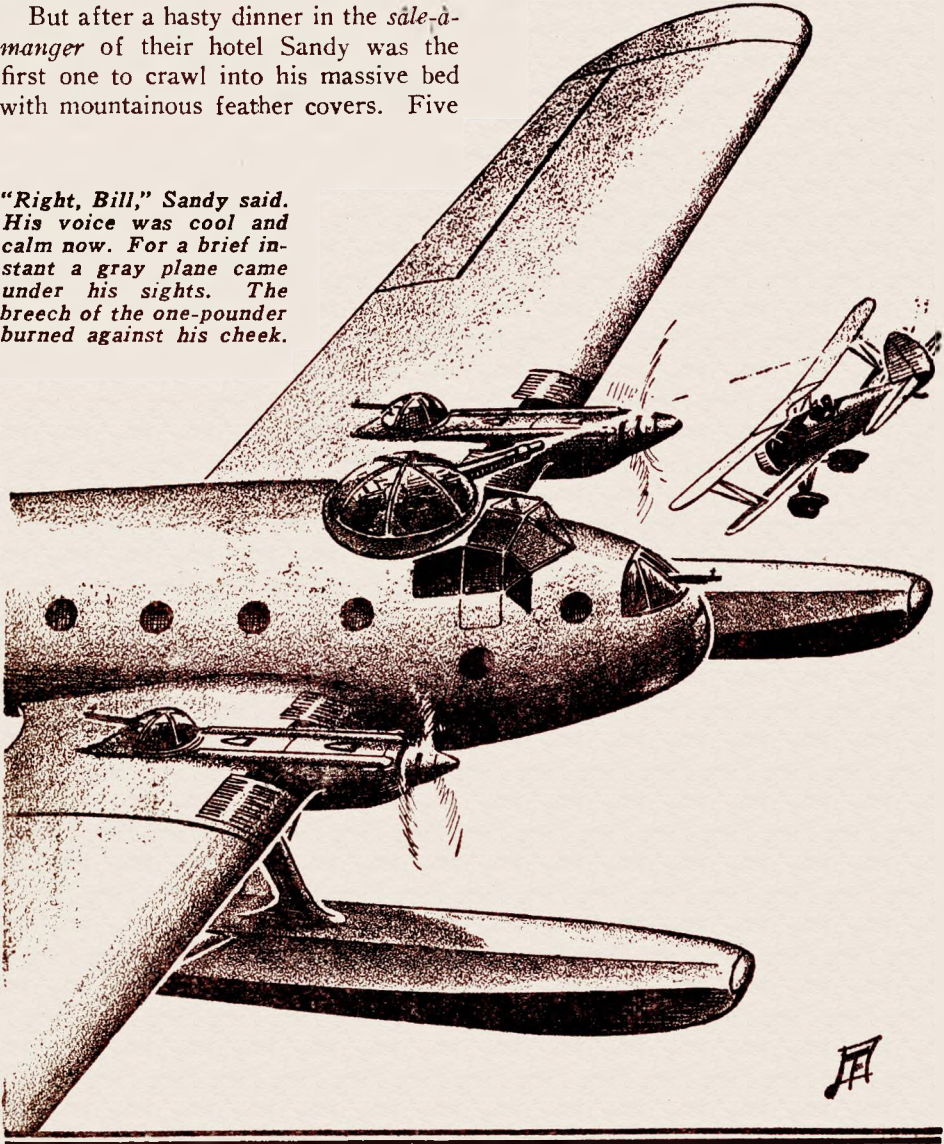

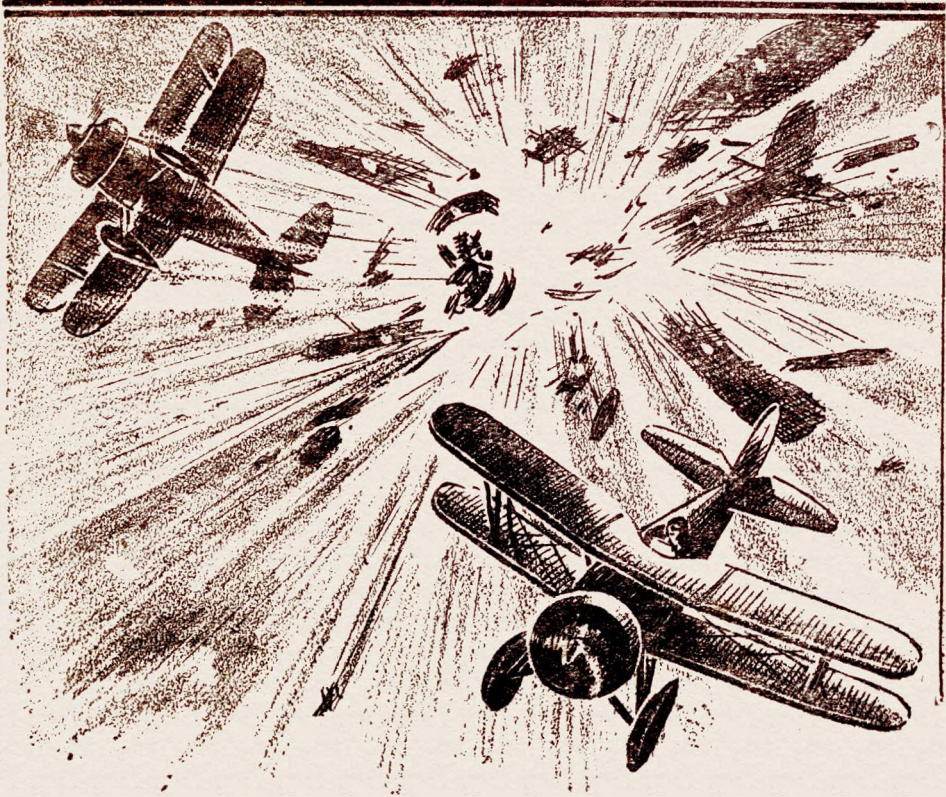

They went to their rooms and were half asleep before they had removed their clothes.

Bill Barnes shook his head wearily from side to side when he and Shorty were finally folding up their maps and charts. He was so tired he could scarcely keep his eyes open. But Shorty seemed to have taken a new lease on life. His eyes were bright and shining. His reflexes and coordination were perfect.

"Don't you ever get tired?" Bill asked him, in disgust.

"I'm tired all right, guy," Shorty said. "But this trip is making a new man of me. A lot of things that have bothered me for years are going to be cleaned up. I can't tell you just how I feel about it. Maybe that's it. It's something I feel. But nothing I can put into words."

"Don't try," Bill said, shortly. "Get some sleep. I want to get the transport in shape to leave here within thirty-six hours."

"That'll give us all day to-morrow."

"We'll need it," Bill said. "I have a hunch we're apt to run into trouble before we see Cairo. Things have been too quiet the past three days. Whoever was gunning for you must know where we are by this time. Judging by their attempt to kidnap you they'll try to meet us on our own field—I mean, with planes. And they may come shooting."

"Fine!" Shorty said, cheerfully. "Nothing I'd like better."

"You've still no idea who is behind it all, or why?"

Shorty shook his head. "Not the faintest," he said. "The only way I can figure it is that some one gobbled

Wyndam's land on Madagascar because it was valuable. When young Dick went out to reclaim it they got rid of him to keep from losing it."

"But who?" Bill asked.

Shorty spread his hands and shrugged his shoulders. "You tell me," he said.

LATE the next afternoon after the starboard Diesel motor had been remounted in the starboard wing stub of the huge carrier-transport, Bill climbed to the bridge, flipped his contact switches and worked the starter. The two powerful motors caught, sending a terrific blast of sand and dirt backward in the slip stream. With his head cocked to one side he listened to the drone of the two engines while his eyes rested on the tachometer.

A few minutes later he slipped his boots into the rudder stirrups and gunned the twin supercharged motors. He signaled to his mechanics that he was going to take the big plane into the air. The giant sixteen-foot propellers had become two iridescent arcs in the sunlight. The low-winged, duralumin plane was trembling like a pointing setter. As the escape doors in the forward compartment came closed and the wide entrance door on the port side was swung to, Bill turned in the pilot's seat and shouted for Sandy. The kid came running forward along the runway beside the Eaglet. Bill pointed to the circular platform above and back of the pilot's seat.

"I'm going to take her out over the Mediterranean," he said. "Get up in the one-pounder turret and when we get out I'll give you a signal. I want to be sure that gun is all right."

Sandy's face beamed. He scampered up the steps to the circular glass-enclosed turret. He had practiced with the rapid-firing gun mounted there. But not enough to satisfy him. He wanted to be able to use the gun with the same deadly accuracy he had with the machine

guns mounted in the Eaglet.

Bill swung the huge ship around into the wind and poured juice into the twin engines. Their muted roar came through the almost soundproof cabin as one. A smile flashed on his lips. Both the motors were doing their stuff to perfection.

The big plane rolled down the runway with lugubrious grace. The flaps came down. The transport lifted almost immediately. Bill took it heavenward in wide, sweeping circles. At ten thousand feet he leveled off. The self-adjusting props automatically adjusted themselves to a new pitch. The monster ship bored through the chilly air at its usual cruising speed of two hundred miles an hour.

Far to the south of them the air quivered and danced above the brilliant-yellow sand of the desert. Picturesque mountains towered thousands of feet upward along the sparkling waters of the Mediterranean. Along the coast wound a white stream cut out of solid rock, high above the sea, forming a *corniche* that is one of the finest roads in the world. Along the same route centuries ago passed Carthaginians and Romans, Vandals and Berbers, Arabs, Spaniards and Turks.

"There's history in them there now hills, kid," Bill said into the plane phone as the Moorish city of Oran faded away behind them. "A high state of civilization existed here centuries ago. But France has developed it. The roads are the equal of the old Roman roads. They extend far out into the desert to meet the great caravans that come in from the heart of Africa. Great men these Frenchmen!"

"The French own Madagascar, too, don't they, Bill?" Sandy asked.

"They do, half-pint," Bill said. "They took it the way the British took India and the Japanese took Korea. They claimed it as far back as 1642 but never got anywhere with their claim.

"In the 1880's they tried to take it

by force but Queen Ranavalona III, drove them out with her own troops under British officers. In 1896 the French sent in twenty thousand French troops under General Duchesne, conquered the island and took control. General Gallieni, the man who saved Paris in the World War by sending reserves to the front in taxicabs, was the first governor of Madagascar for France. The half-military code France uses in all her colonies was put into effect. They developed the roads, built a railroad and taxed the natives. The Hovas were the rulers of the island before the French came. They were traced back to Indonesians, building square houses on piles, wearing sarongs, practicing infanticide, and polygamy and using outrigger canoes. They were tillers of the soil, shepherds and traders.

"Next to them were the Betsileo and Betsimisaraka. They are supposed to be of Arab descent. Then the warlike Sakalavas and the people of Antandroy. They store and eat cactus berries and fruits and, like all the Malagasy, are successful cattle raisers.

"The Sakalavas are big and tall and shiny-black with frizzy hair and flat noses. They practice fetichism, voodoo and are ruled by superstition. They were the last to be reached by the French as a source of revenue. The Sakalavas were great fighters and warriors. They had some neat tricks. They used to dig a hole near an enemy camp and put a huge, red bull in the hole. Then they would cover over the top, leaving a hollow log inserted to give the bull air. When the enemy heard fearful noises coming out of the ground they ran."

"That's great stuff, Bill," Sandy said. "I want to get a book about it."

"Keep it to yourself if you do." Bill grinned. "Shorty and Red will break both your legs if you begin telling them stories about Madagascar as you did

about the Incas when we were in Peru."

"Somebody has to help out the ignorant," Sandy said. "What happened after the French got control?"

"They kept control," Bill said. "They had trouble with the Sakalava's and had to kill a few of 'em. They sent Queen Ranavalona into exile in Algiers and kidded the natives by giving them tin medals and a chance to pay more taxes.

"During the World War the natives tried to poison the French officials because they drafted them for service in Europe. The island is nearly a thousand miles long and is filled with valuable minerals. I think that fact fits in with the attempts to kill and kidnap Shorty. Those maps and papers he has are probably the key to the location of valuable deposits. We'll know more about that soon. We'll hop for Cairo in the morning if this motor is all right."

"She sounds sweet, Bill," Sandy said. "What about giving this rapid-firer a test now?"

BILL LOCKED the controls and crossed to one of the cabin windows. The Mediterranean sparkled blue and green below them. Overhead the sky was a vast expanse of deep-blue, fading to aquamarine and white on the horizon. The city of Oran was a mere speck on the north shore of Africa.

One or two specks that were ships plodded along on the surface of the sea. A gorgeous panorama of land, sea and sky unrolled before his eyes. He listened to the steady drone of the two Diesels for a moment. Then nodded his head with satisfaction. He raised his eyes to the inclosed turret where Sandy sat.

"Let her go, kid!" he said. "Only a few shots at a time or she'll tear out the whole bridge."

Sandy settled himself on the gunner's seat and drew a bead on an imaginary enemy through the telescopic sights. The big ship bucked and trembled as

five one-inch shells went hurtling into space in three seconds. Bill nodded his head as Sandy turned a surprised, questioning glance toward him.

"I wish I had something real to shoot at," Sandy said. "I don't know whether my aim is any good or not."

"Give her a longer burst this time." Bill said. "If she's going to tear out we might better know it now. How does it look?"

"She's secure enough, Bill."

Sandy's fingers clamped down on the firing trip again. The carrier-transport seemed to have struck an unexpected air pocket as it trembled from stem to stern and slid away again.

"She certainly kicks like——" Sandy's voice trailed off as the deafening roar of a half dozen diving airplane motors joined the drone of the twin Diesels. His mouth dropped open as he raised his eyes and saw seven rugged single-seaters with short, flat wings and lean fuselages diving at them out of the sun.

It was not until the noses of those seven gray planes began belching streamers of tracers and lead into the monster transport that he found his voice. Bullets drummed on the tail surface and through the fuselage of the carrier-transport. A thousand tiny lines appeared in the bulletproof glass over Sandy's head as bullets crashed onto it.

"Seven of 'em, Bill!" he screamed. "They're riddling us."

"Hold everything, kid!" Bill roared as he jumped for the starboard pilot's chair and opened the throttle of the twin Diesels wide and pulled back on the wheel.

The muscles in his cheeks stood out like knots of rawhide as his hands wrapped around it. His eyes were thin slits of fire as he watched the seven planes dive by them and ease out of the dive to return to the attack. His whole body and mind seethed with rage at the murderous attack launched from no-

where and without warning. He could see a hundred places where machine-gun bullets had torn through the wings, fuselage and tail of the new transport. It had, literally been riddled in that first vicious attack. Only the fact that the engines droned on without a miss gave him any satisfaction. He wondered what miracle had kept them from being struck.

"Let me take the Eaglet out and pin their ears back, Bill!" Sandy shouted above the roar of the returning planes.

"Sit where you are!" Bill roared. "I'm going to eighteen thousand and lock the controls. Try to keep them off with your gun. I'm going down in the retractable machine-gun turret after I lock the controls. You'll have to take over if anything happens. If you can get any of them under your sights you'll tear 'em to bits."

"Right, Bill," Sandy said. His voice was cool and calm now. He was watching the leader of the seven planes circling upward to get above them again. But the big transport was sweeping upward in tight spirals. It had a good half mile lead as it had turned its nose up. The fleet little single-seaters were rapidly cutting down its advantage.

Sandy whirled the rapid-firer around as the first ship dove in on the transport. For a brief instant the gray plane came under his sights. The breach of the one-pounder burned against his cheek as he clamped down on its trigger. A half dozen savage barks sounded above the throbbing roar of diving motors. Sandy could almost follow the course of the projectiles as they sped toward their target.

Suddenly the target became a great cloud of black smoke, streaked with dabs of saffron and crimson. Ribbons of bright-orange shot out of it as it broke in all directions. The six planes behind the leader zoomed upward to get away from the bits of wreckage that flew in all directions. Wings and fuselage

hurtled through the air as the one-pounders' shells struck the engine block and detonated. The engine—what was left of it—dropped from the black cloud and plummeted toward the earth. A breeze struck the cloud of smoke and it drifted away. What had been a sleek, fast single-seater with a pilot at the controls no longer existed. The one-inch shells had blasted the ship out of the air.

"What a shot! What a shot, kid!" Bill shouted. "That'll teach that pilot a lesson he'll never get over."

"Gosh, Bill. He had it coming to him." Sandy grinned happily. "A direct hit the first time I tried. Gosh!"

"They'll try to come up underneath us now," Bill said as he leveled the big transport. "I'm locking the control and giving the automatic pilot a chance to do his stuff. I'm going down below. Give 'em everything you've got. I'll try to keep 'em busy when they come underneath us."

HE WAS out of the pilot's seat and down the steps to the mid-section of the transport in three jumps. Quickly working the mechanism to set the retractable turret in motion he strapped himself in.

A few seconds later he was suspended in mid-air in the tiny bucket that spun

around at the slightest touch on the controls. As the first gray plane dove and sped back to attack under the tail, Bill's fingers, tightened on the firing trip of the fifty-caliber machine gun. The air between the single-seater and the turret was suddenly laced with white streamers.

The streamers dropped as Bill corrected his aim. The oncoming plane took the full force of the shattering impact of those powerful fifty-caliber bullets. They tore the prop to a thousand pieces and drove into the high-powered motor as though they were being driven into a mud bank.

The windshield and face of the surprised pilot disappeared as though a Houdini had snapped them up his sleeve. Smoke billowed from the housing of the stricken plane as it yawed wildly and burst into flame. The nose of the pilotless plane dropped and it went plummeting toward the Mediterranean eighteen thousand feet below.

For the next thirty seconds Bill Barnes thought he was on a merry-go-round that had gone insane. With his eye glued to his gun sights he fired burst after burst at the attacking planes as they came toward him with their guns belching fire and death. His face was black and grimy as he wiped the perspiration out of his eyes. His whole body was soaked with it. The inclosed turret had become a Turkish bath. The fumes from his gun were strangling him. The sharp roar of Sandy's one-pounder came faintly to his ears as his head began to whirl. The huge transport was keeping steadily on its course as he worked the raising mechanism and stuck his head above the level of the transport deck. He drew great gulps of fresh air into his burning lungs and saw that not a single bullet had touched the retractable turret while he had been suspended below the belly of the plane.

He rubbed his grimy hands across his aching eyes and half staggered up



the steps to the bridge. Sandy was still bent over the sights of his rapid-firer. His blue eyes were shining, his blond hair shooting in every direction.

"You'll have to take the turret for a few minutes, kid," Bill said. "Can't stand it down there for more than a few minutes."

"We don't need any turret," Sandy said, laughing at Bill's smudged face. "They have their tails between their legs. They're five miles south of us now and going faster every minute. They don't seem to like the way we play."

Bill climbed the steps into the turret to join Sandy. Five speeding dots to the south were what remained of the seven planes that had attacked them a few minutes before. He studied the fleeing planes for a moment then gazed downward. There was no sign of the two planes they had torn to pieces with their lead.

"I'm going to look the transport over," Bill said. "You get into the pilot's seat and take us back to Oran."

"Who were they, Bill?" Sandy asked.

Bill spread his hands and shrugged his shoulders.

"They don't want us to get to Madagascar, whoever they are," he said. "It's part of the picture and it fits the frame. I don't think you'll be bored by any more tedious long-distance flying."

He went down the steps leading to the forward machine-gun cockpit to inspect the damage done by the enemy's bullets.

Twenty minutes later, as the city of Oran began to take shape beneath them, he was back on the bridge.

"Anything bad?" Sandy asked.

"Nothing that can't be fixed up to-night," Bill answered. He turned an amused eye on Sandy. "I thought you said you hadn't learned how to use the rapid-firer?"

"I haven't really learned yet, Bill,"

Sandy said, earnestly. "That was just luck."

"You always seem to have a lot of luck," Bill said dryly.

VIII—SURPRISE ATTACK

SHORTY, Red Gleason and Cy Hawkins listened to Bill's report of the attack with troubled eyes as they inspected the damage done to the carrier-transport.

"Where did they come from and where did they go?" Cy drawled.

"Probably from the city of Algiers," Bill said. "It's a few hundred miles down the coast. One of the officials in the office of the field phoned there to find out a few minutes ago. I didn't tell him why I wanted to know. They told him a squadron of ten British planes with private licenses had been there for several days."

"And they said two of them had left to-day," Sandy added.

"And won't be back!" Shorty replied. "I don't suppose there is any use in asking the authorities to hold them until we can get there?"

"No," Bill said. "There would just be a lot of red tape. We would be held if we told our story. They must have permits to fly over French territory or they would already be in trouble. We'll just have to do what we usually do—wait for the other fellow to show his hand."

"By trying to murder all of us," Shorty said bitterly.

Bill scrutinized Shorty's angry features carefully. What he saw bothered him.

"We'll go back home if you want to, fella," he said. "We're still all alive and sound."

"That isn't what I mean," Shorty said. "I don't like the idea of the rest of you being open to murder. It isn't your problem. I'm going on. But I think the rest of you ought to go back."

I don't want to be responsible for anything that happens."

They all gazed at him with expressions that were both affectionate and amused.

"We've always been able to do pretty well when we've been caught in a bad spot." Red grinned.

"Nuts, to him!" said Sandy. "He wants us to go home and do our needle work while he has all the fun!"

ALL THE VINES, flowers and trees were fresh from their night's sleep and covering of dew when the sun poked its nose over the tips of the Atlas Mountains the next morning as Bill and his men fell into formation at five thousand feet.

Below them clustered little Kabyle villages, picturesque from the air but smelling to high heaven if one got near them. The superb road that was the African *corniche* wound along the coast toward Algiers.

At seven o'clock the city of Algiers, rising terrace upon terrace from the sea, appeared below them. Great fields and vineyards spread out in every direction from the city. Huge vans bearing casks of port rumbled toward the wharves. They flew low and circled the airport searching for some sign of the gray fighters they had encountered the day before. They saw nothing to indicate that the planes were still there.

Bill checked his bearings and laid a course due east over the African Riviera toward Tunis.

An hour later they were speeding over the ancient city of Bougie, perched high on a hill overlooking the sea. Encircled by mountains rising seven thousand feet into the air to the south, and the sparkling waters of the sun-kissed Mediterranean to the north, the ruined forts of the old city presented a picture beyond description.

"They used the heliograph in Bougie as early as 1608," Bill said to Sandy.

"I thought the heliograph was a modern discovery," Sandy replied.

"A lot of people think that." Bill laughed. "Bougie had the grandeur of Rome long before America was discovered. The Moors drove out the general of Charles the V of Spain and let him return to Spain with four hundred of his men a little later. That ended the grandeur of Bougie until the French arrived."

"What happened to the general?" Sandy asked, his face alive with interest.

"The king promptly cut off his head," Bill said.

"Nice playmates, those Spaniards."

"Almost as nice as the old-time Chinese," Bill agreed. "But now you're going to see something. We'll be over the Chabêt Gorge in a few minutes. France completed a road through there in 1864."

Bill pointed to the banks and foothills along the narrowing river that were covered with blooming oleanders and roses and spread away to the sea in vast forests of cork and oak trees.

Flying low they could see a troop of monkeys fleeing through the treetops. The winding road below them was cut out of the cliff's side some three hundred feet above the raging torrent that flowed through the gorge. The cliffs rose barren and somber below and the absolute silence was broken only by the drone of their motors. Where lateral valleys entered the gorge beautiful cascades dropped into the boiling river, streaming downward like molten silver in the sunlight. In spots, the cliffs rose from a thousand to fifteen hundred feet on each side and a stone could be thrown across them.

"That's something to see," Sandy said.

"Gloomy and majestic are the words you want," Bill supplied. He looked at his maps and pointed again. "That little village ahead is Kharata. That's where Chabet-el-Akhira begins. When

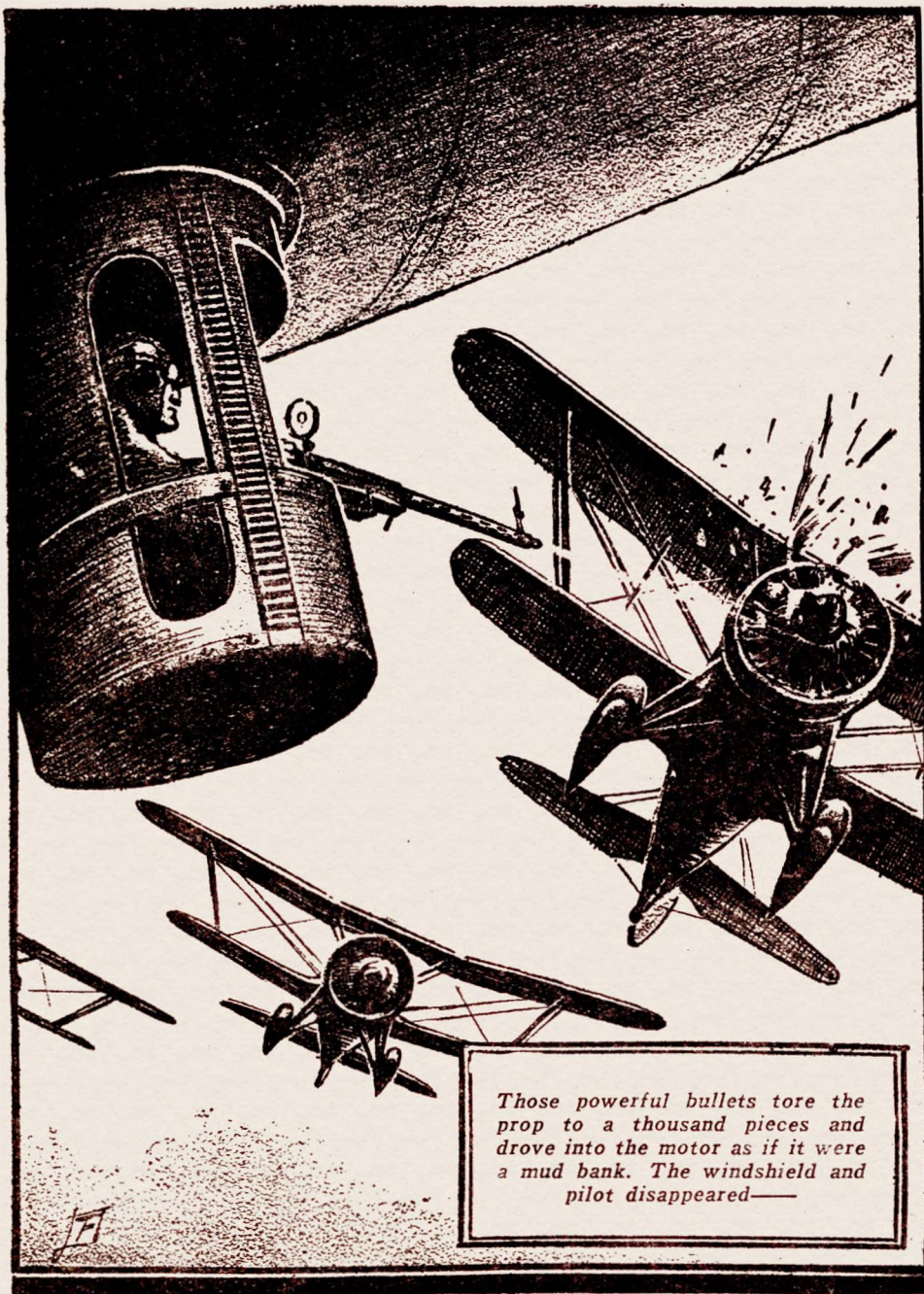

the Sahara Desert was a sea this was probably one of the outlets from it to the Mediterranean."

The snow range of the grand Kabylia rose ahead of them in all its somber grandness as Bill stuck the nose of the transport upward. Not a tree or a bit of green could be seen in the distant valleys. Farther on they crossed a high, dusty plateau some thirty-five hundred feet above the level of the sea. Here and there a native village sprawled in the choking dust that blew in clouds, or perched on the side of a steep hill.

"South of here, kid—about a hundred and fifty miles inland—are the ruins of Timgad. It stands, or what is left of it, at the foot of the Aures Mountains, on the northern fringe of the Sahara. It was founded in the days of Rome and was strongly fortified. The Vandals partially destroyed it in 535. It was restored by Solomon, a Byzantine general, and was like Wall Street in 1928 until the Arabs took a crack at it in 646. After that it was abandoned and the passing centuries covered it with sand until the city was blotted out. Then the French uncovered it to find mosaic pavements more perfect than the pavements of old Rome. Great mansions and monasteries, theaters and luxurious baths, courts and gardens were unearthed. Soldiers from the Augustan third legion used to congregate in the great monastery. The whole place was preserved from the barbaric invaders by the sands of time."

"Gosh, Bill," Sandy said, "you sound like one of those lecturers. Wait until I spill all this stuff to Shorty."

"You'd better lay off, or he'll spill you." Bill laughed. "You'd better contact him on the radiophone. Also Cy and Red. See how they're riding."

Sandy adjusted a couple of dials on the radio panel and spoke to Shorty a moment later. Cy and Red checked in at the same time.

"Bill says to check your maps and

bearings," Sandy said into the microphone. "We'll be over Constantine in a few minutes. Due east from there to Bone and then across the tip of Tunisia to Tunis. Southeast over the Mediterranean to Bengazi in Tripoli. Check back before we start the water hop. It's about seven hundred miles. Eight hundred from Bengazi to Cairo, on the same course."

They all reported their motors turning over perfectly.

"Dinner to-night at Sheppard's Hotel in Cairo," Cy Hawkins cut in. "There's a place to eat. The best food east of Paris."

"That's fine," Sandy said, chuckling. "I want to tell all of you about the ancient city of Timgad which lies on the border of the Sahara about one hundred and fifty miles south of here. It——"

"Go soak your ears!" Shorty and Red Gleason said in unison and signed off.

A FEW MINUTES later the little squadron soared over Constantine, perched high on her cliffs. To the south were vast stretches of lonely yellow mountains silhouetted against the blue sky. Here and there were pale-green meadows over which trains of camels and turbaned Arabs made their way. But on the barren, desert mountains no life existed or ever had existed.

As the little city of Bone flashed behind them, the sad blue-gray of olive groves came in sight, relieved by countless fruit trees in blossom. Almond, cherry, apple and peach blossoms made a bed of delicate hues of the earth, bordered by green fields of flowering narcissus.

At Bone they left the sapphire blue waters of the Mediterranean behind them and roared above mountains covered with groves of cork trees. Dougga, the ancient Thugga of the Romans, stood high on a hill overlooking a fertile valley. Flying low they saw that the once graceful columns of the theater and

beautiful temple of Jupiter and Minerva were now foul with the dirt of human Arabs and dogs.

White Moorish villages flashed beneath their wings, and here and there the low, black tents of the Bedouins dotted the green fields on their course to Tunis.

Over the Bay of Tunis, which gleamed pale-green and opaline against the dark mountains, below them, the Scarlet Stormer and two Snorters reported their motors running smoothly. As green meadows spotted with daisies and buttercups and the delicate pink-and-white of almond trees appeared beneath the roaring planes again, the three fighters went into a series of acrobatics to prove that their motors were clicking and that life was worth the living.

Stately camels and white-robed Moors stared into the sky at the whirling, flashing evolutions. A flock of brown-and-white sheep broke in a hundred different directions, frightened by the roar of their diving motors. Against the green meadow where the sheep grazed rose the blue hills of Tunisia to a bluer heaven, across which white clouds danced in the cool, morning air.

Over the ancient, holy city of Kārawān the four planes roared. Stately Moors wearing white robes and burnouses stalked the streets of the white city of the Orient. Prim camels and humble donkeys were silhouetted against the white walls. A snake charmer held aloft a cobra with distended hood. Peddlers of carpets, of vegetables, of pottery from Naples; white-robed Arabs from the plains, city dandies in robes of purple or blue over white, paced majestically along the streets. White pigeons circled above the domed-tower gateways of the great mosque of snow-white.

At ten o'clock the carrier-transport and three fighters roared above the British island of Lampedusa, far out in the Mediterranean. At twelve they flashed across the northermost tip of Tripoli,

north of the city of Bengazi. At two they were over the Bomba Gulf on a true course for Alexandria in Egypt.

Bill Barnes was sleeping in his bunk in his private cabin as the little squadron droned down the north coast of Africa. The mechanic-gunners of the monster transport were also asleep, except Charlie. He was cleaning up after lunch in the dining saloon and galley. Young Sandy was half asleep at the controls. McCoy, gunner in the starboard wing was puttering about in his cockpit, checking his ammunition.

The Scarlet Stormer was boring through the sun-kissed air above the transport. Shorty had just managed to get Sandy's goat over the radiophone. That helped to break the monotony of the long hop, he told himself, grinning.

Red Gleason was trying to keep awake by singing songs of his own composition to the tune of the motor. The motor, he pretended, sang bass, and he sang what he thought was a rich, clear tenor. Actually, he sounded like a goat that had lost its mother. But with the roaring motor it made no difference. He couldn't even hear himself—which was just as well.

The words he sang made no sense, and the tunes were something a Chinese band would have sneered at. He sang loudest and fastest when his guns were blazing in battle. Right now he was singing a song that he thought had to do with the cities they had just left behind them. He sang:

"I met that gal in Oran,
I kissed her in Algiers,
I threw her out at Tunis—
And wasn't she in tears!

"Not so good, Mr. Gleason," he said to himself, drew a deep breath and started over again:

"She wrote to me at Cairo,
Sent love to Zanzibar,
But I know she's only kidding,
No love will reach that far!"

"Well, well," he gloated. "That's more like it."

Cy Hawkins, in the other Snorter, was almost asleep. He kept his hand on the control column. Each time he went all the way to sleep it slipped off and he awoke with a start. Just at the moment he was dreaming about the dinner he was going to order at Shepherd's Hotel in Cairo.

IT WAS just four o'clock in the afternoon when Bill Barnes mounted to the bridge again, his eyes heavy with sleep. He yawned and told Sandy to go down in his cabin and get a few winks of sleep. As the words left his lips he suddenly stiffened. His mouth became a thin, straight line, his eyes mere slits as he listened for a fraction of a second. Then he leaped for the intercockpit telephone and roared forth orders. He didn't bother to look out the windows. He knew the sudden roar of a half dozen attacking planes only too well.

"Battle stations!" he barked. "We're being attacked."

Machine-gun bullets tore through the surfaces of the big transport. It reeled dangerously and shuddered like a battleship that has been struck in a vital spot by a fifteen-inch shell.

"Take the rapid-firer, Sandy!" he belted, grabbing the controls. "I'll hold her straight on her course and hold her steady." He threw a switch on the radio panel and waited for Shorty, Cy and Red to check in.

"Come back fast, Shorty," he said. "Keep 'em off the transport. Sandy will help with the rapid-firer!" The muscles in his bronzed cheeks bulged as he talked through clenched teeth.

Martin, in the forward gunner's cockpit, scanned the air above him as old Charlie leaped to his station in the tail cockpit and Miles let himself down in the cylindrical turret beneath the belly of the ship. The guns poured a burst of

lead after the diving gray planes as they went by.

As Shorty came streaking back in the Scarlet Stormer the two Snorters tossed their tails in the air and dove on the eight gray planes like thunderbolts. The Scarlet Stormer and the Snorters were like three wild bulls as they tore viciously after the enemy. Tracer smoke, white and yellow, rose in the dull haze as the eight gray planes maneuvered to meet the three diving ships.

Bill's eyes glittered and his fingers were so tightly fastened around the control wheel they appeared to be bloodless as he watched Shorty whip the Stormer through the roaring heavens with the reckless abandon of a man gone berserk.

Gray planes skidded crazily out of his path to escape his lightning acrobatics to bring them under his sights. A gray plane zoomed and went far over on its side with its rudder biting into the air to swing in a tight circle. But the first burst of fire from Shorty's guns cut the rudder from the post. As the gray ship slipped, Shorty smashed its center, his fire raking forward. The pilot half leaped out of his seat, then collapsed over the stick as the ship fell into a spin and plunged toward the waters below.

Two of the fast, gray ships hurtled down on the tail of Red Gleason's plane as he leveled off to come out of his dive. As their bullets ripped the air above his head he kicked his Snorter enough sidewise to throw them off aim. He brought his Snorter around in a tight loop on the tail of one of the gray planes and around harder in a tight vertical. His guns drew a line like the track of a snake from rudder to engine. Smoke billowed from the engine a moment later as the pilot dived and went over the side.

Up near the speeding transport, two of the rugged, gray biplanes were trying to get Cy Hawkins in a cross fire. Their crisscrossing lines of tracers showed that he was outmaneuvering

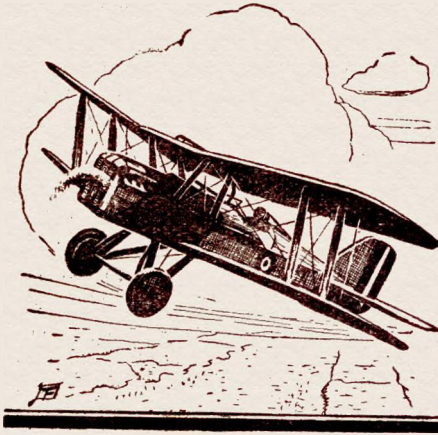

them, waiting for an opportunity to slip out and attack.

As the Scarlet Stormer sped back toward the transport with three gray planes in pursuit, Sandy's finger clamped down on the firing trip of the rapid-fire gun. The big transport bucked and trembled as he fired burst after burst toward the three gray planes. They were too far away for effective shooting and they followed Shorty only to a certain point. They had tasted Sandy's marksmanship the day before and evidently had orders to stay out of his range of fire.

As Shorty swung around in a chandelle his blue eyes were gleaming with that recklessness that always rode with him when he rode close to death. He tore the formation of the three planes apart as they dived and zoomed and rolled to get out of the path of the mad man that turned neither to right or left, his guns belching death.

As the three planes whirled to pounce on him he flipped over like a hawk and shot across their rear. His fingers clamped down on his triggers as he caught one of them under his hair sights. The burst of fire lasted a mere second and a half, but his aim was deadly. The plane slipped off on one wing and began to flutter downward, half out of control as the pilot fought desperately

to bring it to an even keel.

Red Gleason was riding his ship with the same reckless abandon characteristic of Shorty. He followed a gray plane as it pulled steeply up into the sky, went over in a half loop, rolled right side up and came tearing back at him with guns chattering. Bullets ripped through the starboard wing of his Snorter. He pushed his stick forward and went into a dive. He felt his machine shudder and tremble as the bullets from the gray plane drove through his tail surfaces.

The next second he jerked his stick back into his stomach and zoomed vertically in the sky and over on his back. Neutralizing his controls, he opened the throttle and was on the gray plane's tail. Hanging head downward, he lined up the enemy ship in his hair sights and tripped his guns. Fire and smoke belched from the biplane's engine housing as Red went by it. He threw the stick to the left, rolled right side up and came around in a swirling, vertical bank. He held his fire as the gray plane became a whirling ball of red smoke plunging to its death.

Bill saw Cy Hawkins flash over in a dazzling inverted loop to come up under the tail of one of the planes that had held him in a cross fire. As Cy's guns poured lead and tracers at the enemy ship two more planes dove on him from above. Their tracers and lead smashed into the Snorter's engine. A savage curse ripped from Bill's lips as he saw clouds of black smoke and orange flame pour from Cy's engine housing. He swung the transport around in a sweeping turn and switched on the radiophone.

"Shorty and Red!" he shouted. "Stick close to me. Cy's been hit. His plane has caught fire. I think he's going to bail out. Stick beside him and protect him on his way down. There he goes!"

The flaming fuselage of Cy's Snorter was whirling earthward when something shot out of the cockpit to go tumbling

and turning toward the Mediterranean below. A white streamer came out behind it that a moment later became a large cotton ball.

Bill's face was livid with rage as he saw one of his Snorters whirling downward. He shouted at Sandy. "Why don't you knock a couple of those ships out of the air? Are you a cripple?"

Sandy looked down at him with the expression of one who has been grossly insulted.

"Knock 'em down?" he shouted back. "They won't come close enough to give me a crack at them. And now they've all turned tail and are streaking toward land. That is, all that are left. Shorty got two of them and Red one. That's five in two days. What more do you want?"

Bill laughed. He couldn't help it. Sandy's injured dignity was too much for him.

"All right, kid," he said. "I take it back. How's Cy coming on?"

"He's all right unless he's wounded," Sandy said. "Shorty and Red are sticking right beside him. You couldn't hurt that leatherneck."

IX—MADAGASCAR

TWENTY MINUTES later Red Gleason made a landing on the smooth, blue waters of the Mediterranean and picked up the struggling Cy Hawkins.

"We'll make Cairo in a couple of hours, Cy," Bill said over the radio-
phone. "Think you can stand your wet clothes until then?"

"First time I've been cool to-day," Cy answered. "I'm sorry they got the Snorter, Bill."

"It's O. K., as long as they didn't get you," Bill answered. "You sure you're all right?"

"Not a scratch," Cy answered.

Bill circled above the debris of the four shot-riddled planes for a half hour

before he put the transport back on its course for Cairo.

"No sign of any life," he said. "All their pilots must have been dead before they hit the water."

"The one who went over the side was badly wounded," Shorty put in. "His face—but let's skip that. We'd better keep our eyes peeled from now on."

"All the time," Bill answered. "Shorty, you stay down on the starboard side of the transport now. Red on the port side. They only have five of their ten planes left unless they have picked up some more. They must be heading for Madagascar. Anything about any of them you recognized, Shorty?"

"Nothing," Shorty said. "Except that the tactics of their leader reminded me of the strategy of a German War ace I had a few brushes with during the War. Same maneuvers and way of executing them. He knew his onions."

"Well, keep your eyes open," Bill said. "We'll need a good rest to-night. Anything may happen to-morrow."

But nothing out of the ordinary happened on the morrow. After dinner at the famous Shepheard's Hotel in Cairo they all went to bed and slept until five the next morning. At six o'clock they were warming up their motors, ready to take the air.

Suddenly, while Shorty and Red were waiting for Bill to wave them into the air, a yellow gloom descended upon the whole world. The nonshatterable glass in their windshields and in the hatches overhead appeared to be fitted with yellow glass. Mechanics and pilots and passengers had disappeared from sight. The place was as still as a tomb except for the roar of their motors. The sky above them was filled with a golden glow, but the air was still as death. Back in the city of Cairo the great mosque of the citadel and the mountains of Moukatam gleamed yellow in the dim

sunlight. All the houses and trees were powdered in gold dust.

Bill Barnes flipped the switch on the radiophone and roared into it. "They're opening the doors of the hangars. Get back inside!"

Even as he spoke the sobbing and sighing of winds—winds from the recesses of the farthest deserts—rose. Almost instantly they were in the midst of a shrieking sandstorm. The world was alive with sand.

They ran their ships back into the hangars. Both they and their engines were half stifled. After the hangar doors were closed the dust penetrated through cracks and crannies and filled the hangar. It got into their hair and lungs and penetrated the cockpits of their planes. They gasped and choked for breath, feeling half strangled.

"It's a good thing that broke before we got into the air. That sand penetrates anything. We'll have to clean our motors before we start out again," Bill said, trying to wipe the sand out of his eyes.

THREE HOURS LATER, after the storm had passed, Bill was pointing out the pyramids to Sandy from the air. Far off to the left the dim outline of the broad Suez Canal joined the Gulf of Suez, while the yellow desert sands stretched away on either side to meet the sky. Tiny dots that were camels formed a long caravan toward the city from across the Libyan Desert and Arabia. In the city below great masses of people were congregated on the steps of the mosques to observe the Holy Carpet's return from Mecca and its reception by the Khedive.

Bands playing European martial music led the lancers in blue and white and a khaki regiment wearing the scarlet tarboosh on the streets below. Heralded by mounted soldiers and the royal salute, the Khedive rode in a barouche drawn by four matched bays in gorgeous har-

ness. Bugles blew; the rattle and noise from the city was tremendous. They were glad to turn the noses of their ships down the green valley of the Nile.

Two hours later as they flashed above the first cataract at Aswan the whole character of the Nile changed. The wide green valleys and distant mountains and deserts disappeared. From where the cataract gripped the Nile at Aswan the land southward became barren hills, all black and yellow, with only a patch here and there of vivid green. In those green patches could be seen a white house or the glistening dome of a sheik's tomb, but more often the low mud hut of a native near which a camel was tethered, or a donkey asleep. Date palms waved majestically back and forth along the banks of the twisting silver ribbon that was the Nile.

The morning sun sparkled brilliantly on the pale-green waters of the river where it washed against the base of the temple Abu-Simbel, built by Rameses II, more than three thousand years ago. At the base sat four great seated colossi and above the statue of the wife of Rameses, watching the approach of the three thundering airplanes with the same expression of tranquillity they had watched the boats of Greeks and Romans, Saracens and Turks through thirty-three centuries from their temple of solid stone.

The boats on the river beneath them were of the same shape as those of the twelfth dynasty and the clothes of the people in Wady-Halfa were the same as then. Flying low they circled the city of Wady-Halfa spread along the eastern bank of the river in the Sudan. A minaret pierced the blue sky among the mud houses of blue, yellow and pink embowered in acacia trees. The air from the broad river blew cool and fresh while that from the Nubian Desert to the east came at them like blasts from a fiery furnace as they altered their course southeast.

As far as they could see ahead of them nothing could be seen but the brilliant yellow sand of the desert, hot and sizzling, over which the air quivered and danced.

Along the bed of the railroad, which Bill intended to follow as far as Atbara, the rails were inclosed on each side by fences and barriers to keep off the drifting sand. The desert sands stretched away in a dead level, covered with a desolate gray brush, like sage. Skeletons of camels and an occasional gazelle were the only things that met their eyes, except the desert and the sky. Heat rolled in on them until they felt that they were about to smother. Then the fifth cataract of the Blue Nile flashed below and the desert cities of Berber and Atbara. Now the shadows were

beginning to lengthen and the sun lost some of its fierce directness. The winds from the Nile and the mountains of Abyssinia fanned their faces, cool and delicious, as Bill took his bearings and left the Nile and the railroad, to follow the Atbara River across the Sudan, and the corner of Eritrea, and the northern portion of ancient Ethiopia to Djibouti, in the Somali coast protectorate of France.

They set the three planes down on the field at Djibouti with aching bodies and red-rimmed, burning eyes. A cool wind off the Gulf of Aden revived them long enough to allow them to eat a hurried dinner and fall into their hotel beds utterly exhausted. Not even the heat of twelve degrees from the equator could keep them awake.

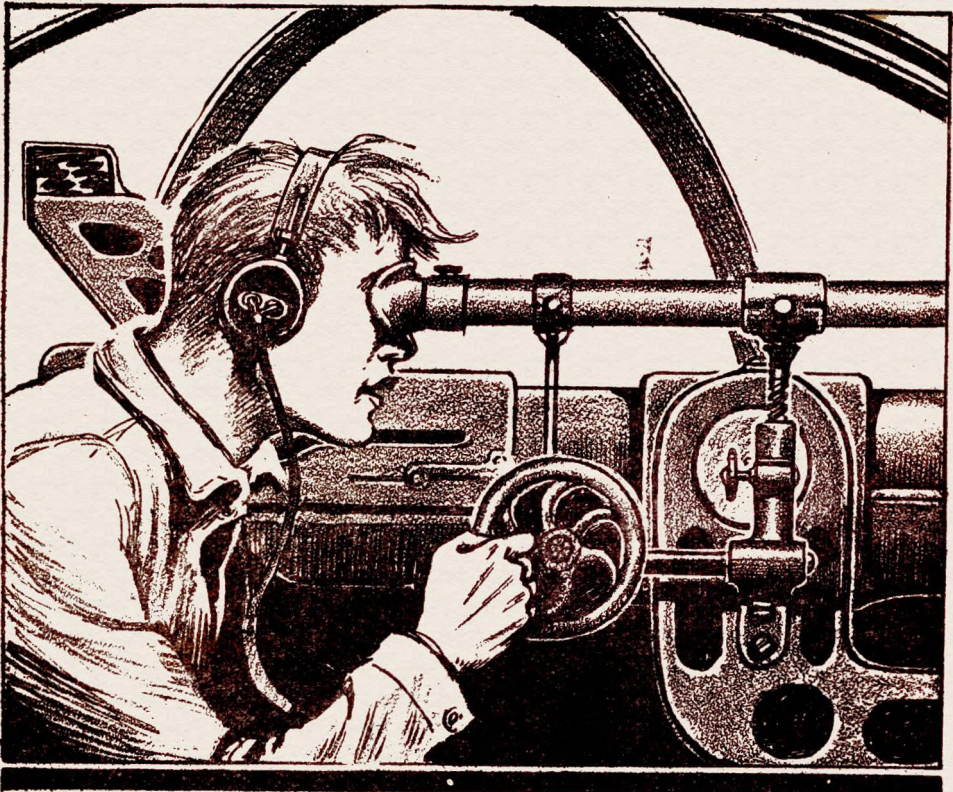

"We don't need any turret," Sandy said. "They have their tails between their legs now, and going faster every minute!"

WHILE they were eating breakfast the next morning the proprietor of the hotel led a man into the dining room. He approached Bill respectfully and spoke to him in English. Then he presented the dark-skinned, curly-headed man following him. The man bowed low and spoke to Bill in a language Bill could not understand. After the bow and speech he reached into an inner pocket and drew forth a letter which he presented to Bill. Bill turned the plain white envelope over curiously.

"Where is he from and what does he want?" Bill asked the proprietor. He spoke with the man for a moment in that same curious language. Then turned back to Bill.

"He says the letter will explain everything. And there is no answer. He asks to be excused if you so order it."

Bill smiled and gesticulated with one hand. "Tell him I so order it," he said.

The dark-skinned man bowed and turned on his heel without another word. The proprietor went back to his desk. Bill's men watched his face while he opened the letter and read:

One of my most trusted servants will bring this letter to you.

Please do not disclose the contents to any person.

When you have finished with your present mission will you be gracious enough to become my guest, in my palace, in the capital city of my kingdom, Ahmara? It will be to your advantage and to mine.

It was signed, "Rarah, II, King of the Sun, the Moon and the Sovereign State of Jogam."

Bill studied the letter for a moment, then stuck it in his pocket. At first he had been tempted to pass it around the table to his men. But something restrained him. Something he could not identify. He turned in his chair and saw that the dark-skinned man with curly hair was regarding him through the door. The man turned away with a nod as his eyes met Bill's. He began

to eat again, paying no attention to the curious glances of Sandy, Shorty, Red and Cy.

"Gosh, Bill!" Sandy exploded at last. "What was it—a check from home?"

Bill laughed and shook his blond head.

"I'll tell you all about it later. When I know what it is myself." He finished his breakfast and prepared to leave the dining room.

"Be sure of your motors before we start out to-day," he said. "To-day is going to be the toughest spot of all. I'm going to cut straight down across Abyssinia into Kenya and Tanganyika to Zanzibar instead of following the coast. Nurse your engines. We'll go high enough to get away from the equatorial heat, if we can. To-morrow night we'll be in Tamatave, on the east coast of Madagascar."

Bill knew only too well the countless hazards ahead of them that day. The deserts, high mountain, jungles and savage natives would be something to consider if any of them were forced to land.

As the three planes sped across the border of Abyssinia into Kenya at noon-time they were all aware of their proximity to the equator. Below them was a solid mass of tangled forests crowded with unkempt, ghostlike trees. Humid, enervating air rose from the too-luxuriant vegetation and vast stretches of marshy, unwholesome swamps.

"Another four hours does it," Bill said into the radiophone.

"Another two will do for me," Sandy said, wiping the streaming perspiration out of his eyes. Bill laughed and took the controls from him.

It was almost to a dot that they set the three groaning planes down at Zanzibar four hours later. They chose the splendid harbor of the city for a landing place at the coralline islands, it being one of the finest ports in Africa.

Sandy gasped at the beauty of the place. "What do they do here, Bill?" he asked.

"Cloves," Bill said, shortly. He was tired and he looked it.

"What do you mean, cloves?"

"Cloves you put in hams and pies. You ought to know all about that," Bill said. "They have almost a world monopoly on the clove trade."

But Sandy wasn't interested in the clove trade. He was interested only in getting into a cold bath and then into bed. He didn't even want any dinner, which made Bill look him over carefully, fearing that it was a sure indication he was ill.

ANY ONE could have told the next morning that he wasn't ill. He was up and around with a beaming face that made the weary Shorty Hassfurter groan.

"Do you know what they do on this island, Shorty?" Sandy asked him.

"Applesauce!" Shorty said.

"No," Sandy explained. "Not applesauce. The stuff that goes in applesauce—cloves!"

Just before Shorty went back to the Scarlet Stormer he drew Bill aside and spoke to him.

"I meant to ask you last night," he said. "What was that note you had at Djibouti? I mean, did it have anything to do with this expedition?"

"Not a thing," Bill said. He drew the letter from the pocket of his jacket and gave it to Shorty to read.

Shorty read it with widening eyes. "Do you know who this bird is?" Shorty asked.

"Vaguely," Bill said. "I can't remember the things I've seen in the papers about him recently. His name is familiar."

"A strong European power is trying to gobble his kingdom," Shorty said. "That will stand a little investigation."

"When we're through with this job," Bill said, dismissing the matter.

A half hour later the Scarlet Stormer streaked across the harbor of Zanzibar

and soared into the air, followed by Red's Snorter and the huge transport. Three hours later they rounded Cape Amber, the most northerly point on Madagascar. Taking a course that cut above the city of Diego Suarez they fled down the coast of the large island to the spacious harbor of Tamatave. They circled above it and the city while Bill studied his maps.

The exertions of the panting *filanzana* carriers, naked except for scanty breechcloths and finely woven straw hats, caused the gaping Sandy to wipe the perspiration from his own brow. The steaming city seemed to be baking beneath the tropic sun. A native band played listlessly in a savanna near the pier of the Messageries Maritimes. Native girls strolled along the cobblestone streets arm and arm with men clothed only in loin cloths and the native *lamba*.

Sandy wrinkled his nose at the signs of heat and dirt and noise below him. He turned and spoke to Bill.

"This looks like an awful hole," he said. "Hotter than a little red wagon."

Bill nodded and threw a switch on the radiophone panels. He waited for Red and Shorty to give the all-clear signal.

"There doesn't seem to be any use in wasting a night in this place," he said. "The information we want will be at Tananarivo. It's only about a hundred and fifty or seventy-five miles back from the coast—eighteen hundred meters above sea level. It will be cooler up there. An hour will do it. Shall we go on?"

"Let's go!" Shorty said. "This heat is terrific."

"O. K.," Bill said. "I'll follow the course of the railroad."

They took a course in a southerly direction along a narrow strip of land that was separated from the mainland by a series of lagoons. On the easterly side, giant combers of the Indian Ocean came

rolling in to break in a fury of foam and spray.

At Tranokoditra, as though tired of the incessant pounding of the sea, the tracks turned west and buried themselves in the dense tropical forest. Great masses of bougainvillæa, hibiscus and clematis stood out in brilliant splotches of color among the raphia palms, tree ferns and tall beefwood trees.

They followed the tracks steadily upward through the valley of the Vohitra, where the forest belt was broken by numerous hills whose outcroppings of rock assumed weird and fantastic forms. Giant waterfalls hissed out of the gorges and plunged into the valleys below to follow their course to the Indian Ocean.

As the forests gave way to grassy uplands the air became distinctly cooler and brisk. Another climb of a thousand feet brought them over the brim of a plateau that spread out as far as they could see. The province of Imerina lay below them like a giant relief map. In the distance a long, blue ridge arose directly from the plain. On the very back of the ridge they could discern the lofty towers of the royal palaces, and spread out all about them the pink doll's houses that made up Tananarivo, the capital.

The city was built on a Y-shaped ridge, the peak of which rose to a height of about seven hundred feet. The houses, all built of pinkish brick, were set on the sides of the hills in tiers, giving the city the appearance of being a huge amphitheater, with the widespread moors of Imerina the stage of the players.

Broad flights of steps connected places too steep for *pousse-pousses* or the small motor cars that whisked through the narrow, winding streets. Beautifully arranged walks and terraces surrounded the central plaza, from which broad steps led to the highest point on the ridge, where, before the

conquest of the island by France, the Hova queens dwelt in their fantastic palaces.

Bill Barnes studied the strange city with interest. He wondered how the French had been able to conquer it with so small a force of men.

"If the three million natives of fighting age were armed with machine guns and well organized they could drive he French into the sea," he said to Sandy. He spoke into the radio microphone.

"It looks as though we sit down outside the city," he said. "Take it easy. I'll go in first."

Three minutes later he brought the huge transport to a halt on a flat, even field, just off the edge of the city. The Scarlet Stormer and Snorter with Cy Hawkins at the controls of the latter fishtailed in beside him.

"That," said Shorty Hassfurter, as he climbed out of the Scarlet Stormer, "is that. Across the Atlantic, the top of Africa and three quarters of the way down the east coast. I'm tired."

"Grandpa is feeling his age," Sandy said, with a grin.

Two French cars came tearing across from the city toward them.

"Let's get cleaned up at a hotel and then poke around," Bill said.

Shorty's bloodshot eyes brightened. He was tired but the thought that this was the end of his journey and the possible solution of a thing that had bothered him for seventeen years gave him new life. He slapped his hands together with the forced enthusiasm of a quarter back in the last minute of a grueling game of football.

"Let's go!" he said.

X—FORGED RECORDS

THE NATIVE DRIVERS of the two cars threaded their way through bicycles, motor cycles, automobiles and oxcarts on the streets of Tananarivo. Handsome, straight-haired and brown-

skinned natives walked through the streets, clothed only in their *lambas*, bearing baskets containing eggs and rice, bright-colored mats, live chickens and geese, on their heads. Cast-off European clothes, strange and doubtful medicines, baskets of dried locusts to eat, empty bottles and tin cans, were among the wares offered in the market place.

Bill and his men found that the best hotel the capital offered was far from good. The American consul told them later in the day that all the hotels on Madagascar ranged from *very bad* on down. They were inclined to believe him.

"Let's not lose any time," Bill said to Shorty after he had tried to get clean. "Get your maps and papers together and we'll go to the administration building and check up on the location of Wyndam's property with their records. But don't tell them anything. Don't let them know just what we are after. In other words, we'll learn what we want to know without giving them any information."

"What about the language?"

"We'll find some one who speaks English," Bill said.

After some difficulty they made the driver of one of their cars understand that they wished to find the government buildings. Once there they found the department they wanted by means of pantomime and Shorty's bad French.

The official in charge finally sent for a Frenchman who spoke a smattering of English. They made him understand what they wanted to know. He brought out a government map of the country along the automobile road connecting Tananarivo and Ankazobe to the northwest of the capital.

In an hour they left the building and they knew what they wanted to know. While they were comparing Wyndam's crude map with the government map and tax records Shorty almost gave away the reason for their search. The Frenchman who was helping them

looked at Shorty's trembling hands and flushed face with a curious expression. An expression that caused his eyes to narrow down to mere slits as Shorty put his finger on a certain spot on the government map.

"These fellows bought this land direct from the government?" Shorty asked, holding his finger on that spot on the map.

The Frenchman nodded his head, and added: "*Oui, monsieur.*"

"No one else owned it before they bought it in 1928?" Bill asked.

"*Non, monsieur.*"

They shook hands with the Frenchman, who said his name was La Coste—André La Coste—and took their leave.

When they were outside Shorty could hardly restrain himself. He stopped and began to jabber to Bill in much the same manner natives had spoken to him since their arrival.

Bill laughed. "Keep your shirt on, fella," he said. "Take it easy so I know what you're talking about."

"O. K., Bill," Shorty said, his blue eyes gleaming. He swallowed and took a deep breath.

"This is what I'm trying to say, Bill: Things are beginning to click in my mind now. You remember I said the leader of the men who attacked us over the Mediterranean reminded me, or his flying tactics, reminded me, of a German pilot I fought with several times during the War?"

"I remember," Bill said.

"Heilner was his name," Shorty said, his eyes flashing. "Eric Heilner. He was a German squadron commander, famous in our section. Do you see what I'm getting at?"

"I'm a little slow on the uptake, I guess," Bill admitted.

"Eric Heilner is the name of one of the three men who now own Wyndam's property. The other two, Boettner and Zimmerman, mean nothing to me. But Heilner does. Don't you see?"

He might have been one of the Germans who landed beside Wyndam and me behind the German lines the day Wyndam was killed. Heilner may have found other papers on Wyndam, papers he forgot to give me!" Shorty waved his arms excitedly.

"I don't know how he got here or what he found on Wyndam. Or how those three Germans got possession of Wyndam's property. But I know now why they wanted to search my things. They were looking for Wyndam's deed and the survey of his property. They must have stolen it in some way and bribed some one to alter the records. That's why young Dick Wyndam disappeared so mysteriously. They didn't want him nosing around. So they got rid of him. Do you get it?"

"I get it," Bill said slowly. "It sounds fantastic but stranger things have happened. Heilner may have found papers on Wyndam telling about

the location and value of his land. He got Boettner and Zimmerman to investigate with him. When they found out it was valuable and no taxes had been paid in years they bribed some one to alter the records. That's clear enough. But how did they know you had those papers?"

"How the heck do I know?" Shorty said irritably. "Maybe Wyndam had written a letter home that he hadn't mailed or carried a diary in which he said I was going out to Madagascar with him after the War."

"That property must be valuable—very valuable, to cause them to go to so much expense and trouble," Bill said. "The thing for us to do now is to go

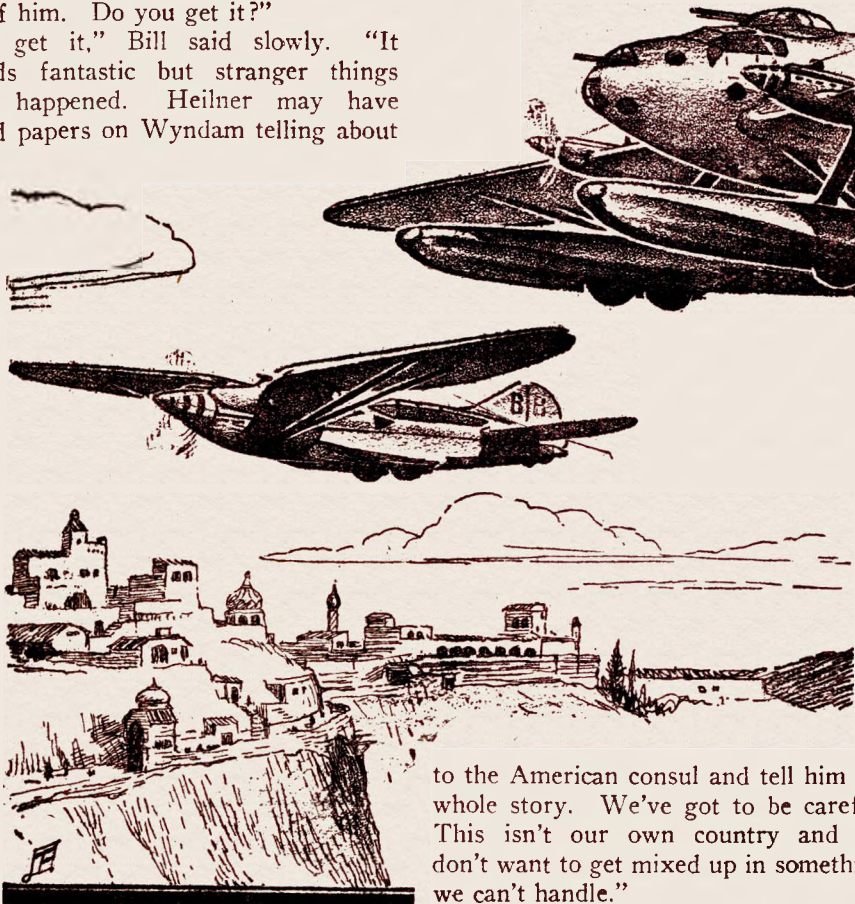

to the American consul and tell him the whole story. We've got to be careful. This isn't our own country and we don't want to get mixed up in something we can't handle."

"Why don't we fly out beyond Ankazobe first and look the place over."

"Not until after we report to the consul," Bill said firmly.

STURGIS BENTON, the American consul to Madagascar, greeted them cordially a half hour later. After a brief chat about their trip to Madagascar he suddenly asked them a question that startled both of them.

"Did you land some of your planes on the west coast of Madagascar, at Majunga, Mr. Barnes?" he asked.

"No," Bill said, glancing at Shorty.

slowly. His expression was solemn and a little perplexed.

"I thought when I heard of your landing to-day that they were part of your squadron," he went on. "Of course, you have papers giving you permission to fly over and land on French possessions?"

"Certainly," Bill said. "I have more or less permanent papers from all the nations of the league."

"I had forgotten," Benton said, smiling. "We're a little out of touch with things out here. Except for a few new roads and our wireless masts, Madagas-

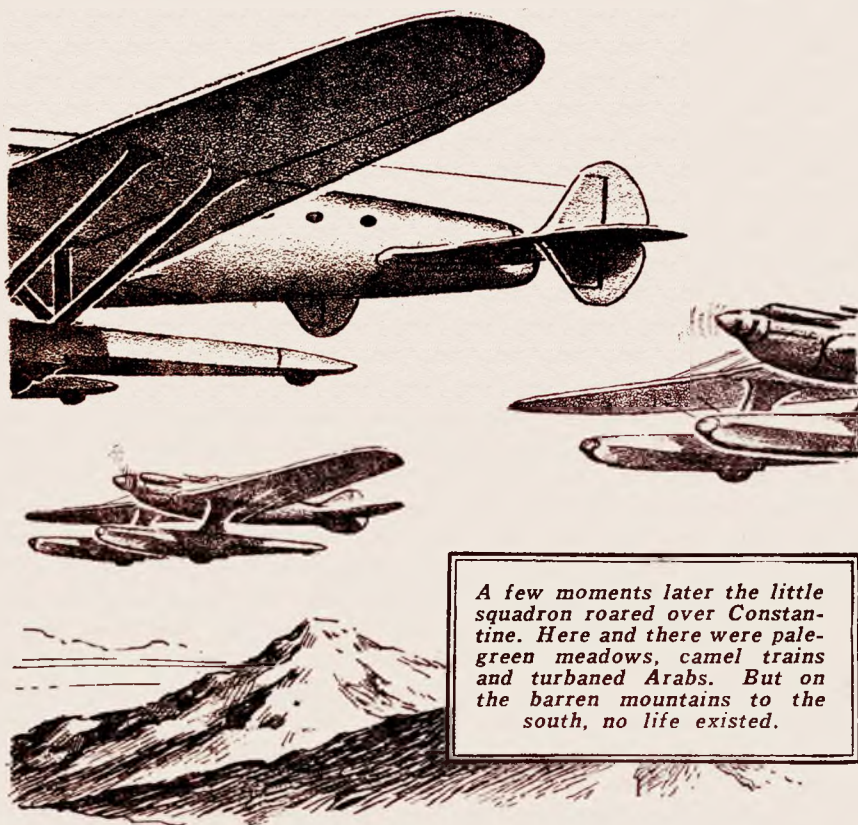

Shorty had edged forward on his chair.

"Five single-seater biplanes and a twin-motored bomber landed there yesterday and took off this morning in a southeastern direction," Benton said

car is much as it was when the French took possession forty years ago. But how do you account for those other planes?"

"We'd better start from the begin-

ning," Bill said, looking at Shorty again. Shorty nodded his head in confirmation.

Sturgis Benton sat on the edge of his chair, his expression one of incredulous wonder as Bill unfolded the story of why they were in Madagascar, the events leading up to their trip, and the facts they had learned since they landed. When he had finished, Benton slowly relaxed, slid back into his chair as his breath whistled through his pursed lips.

"Young man, I know you know your own business better than any man on earth. But now you're mixed up in something a great deal bigger than yourself. Bigger than any individual!"

Bill and Shorty waited for him to go on.

"What I mean is that undoubtedly there is another revolt afoot and the governor-general should be informed immediately. There have been rumors of trouble recently. But they come periodically. The secret service has been investigating. With your information they can probably put their finger on the trouble.

"It looks very much to me as though you and all your men were in great danger of your lives. These Germans have tried to get the deed and papers Mr. Hassfurter carries at the risk of their own lives and yours. There may be international complications in this thing. We don't know whether they are working for themselves or whether they are stirring up trouble for some other power. If they have armed planes they must have them for a reason. Valuable gold deposits, all kinds of minerals and precious stones, except diamonds, have been found in that region. They may plan to take out their finds by plane. You can understand that we must report the thing to the French officials."

Shorty rose to his feet and began to pace back and forth across the room. Suddenly he stopped and threw out his hands.

"Listen, Mr. Benton," he said. "I've

seen what happens when you report things to officials. I've seen it ever since I was a kid twenty years old, in the army. When you report things to officials nothing ever happens until the culprits have been warned and allowed to escape. I came out here to find young Dick Wyndam, if he's still alive. I know how the French go about things. They talk and wave their arms and argue. But they don't do anything. I came out to find young Wyndam. And I'm going to find him. I'm not going to wait for the French officials to scare the men who know where he can be found, dead or alive."

"Take it easy, fella," Bill said.

Sturgis Benton sat perfectly still gazing at Shorty with eyes that were both understanding and full of admiration.

"I know what you mean," he said. "I understand perfectly. I see enough of it." He sat with eyes half closed for a minute. "You have a large transport and two double-seater monoplanes with you?"

Bill nodded.

"All right," Benton went on. "Let's see that map again." He studied it for a moment. He looked up and said: "You can carry another passenger in your transport?"

Again Bill nodded. But he did it with reservations. He didn't want the responsibility of an American consul with him in case he ran into trouble.

"Well," Benton said, "I shouldn't, but I'll get you a guide. He will be able to direct you over the route you'll have to fly to get to this place beyond Ankazobe. You should be able to investigate the place thoroughly within a day. I don't know whether you will be able to land up there or not. But if you aren't back the same night I shall go to the governor-general and lay the whole thing before him. Is that satisfactory?"

"That's satisfactory," Bill said. "And fair. That gives us a chance to do what we want to do without alarming Heilner

and his crowd. He'll be expecting us anyway. French troops might spoil everything."

"I'll get you a trustworthy Betsileo. He knows the whole island thoroughly, and he won't be in the way if you run into trouble. He is one of the few natives who fought with French troops during the War."

Bill and Shorty shook hands with Sturgis Benton and left.

"I'll have the guide at your hotel at any time you wish in the morning," he said before they departed.

"Five o'clock," Bill answered. "That'll give us lots of time to poke around tomorrow."

XI—AN ULTIMATUM

THREE MEN and a girl sat at a small metal table in one of a series of unburned brick houses and barracks on a wind-swept plateau of Imerina, the chief province of Madagascar. They were an ill-assorted lot.

Far to the southeast in a purple haze that rimmed the horizon loomed the rolling Ankaratra Mountains. To the west, outside the crudely built fort that housed the barracks, parade ground and arsenal, thousands of hump-backed cattle grazed. A few miles to the east and west flowed forked tributaries of the Betsiboka River alive with gigantic, man-eating crocodiles. Placed at strategic positions along the walls of the fort were raised machine-gun platforms that commanded a sweep of the plateau in every direction.

On the outer edge of the parade ground, spaced at intervals, mobile anti-aircraft guns pointed toward the indigo sky. Anchored in concrete in the center of the inclosure were a dozen howitzers and long-range naval rifles that commanded the rocky country directly to the south of the fort. To the north, east and west the place was practically

immune to attack because of the Betsiboka River. A half dozen men could hold the place against an army approaching over the steep, rocky country to the south.

Thousands of tall, muscular Malagasy natives milled about within the fort and tended the grazing cattle outside. Bare-footed, attired only in breechclouts, their black bodies rippled and gleamed under the play of powerful muscles. A sergeant, wearing a colored sash and an automatic about his waist to indicate his rank, drilled a company of infantry in a far corner. His voice floated across the parade ground to the ears of the three men and the girl.

Adolph Boettner and Hans Zimmerman regarded Eric Heilner's hideously scarred face with cold, metallic eyes. Their blue eyes were as hard as their large faces were cruel. In the deep-brown eyes of the girl, Cistra Boettner, there was an expression of terror and fear. She shuddered as she saw the sinister evil stamped on the faces of those three men. She spread her graceful hands on the table, palms upward, in an expression of appeal.

"Why can't we drop this whole hideous thing?" she pleaded. "I never would have agreed to come with Uncle Adolph if I had known the truth. Nothing but murder and violence and——"

"Shut up," Adolph Boettner roared at his niece. The girl winced as though she had been struck and turned appealing eyes toward Hans Zimmerman and Eric Heilner. But they were not interested in her appeals now. They were interested only in the survival of their plans.

"Most girls," Adolph Boettner growled, "would jump at the chance to become a queen. You'll rule this island when we have completed our plans. You——"

"If you don't have your throat stretched," Heilner sneered.

"And whose fault is it?" Zimmerman wanted to know. "We make all the preparations and then men we thought we could trust ruin our plans. Kurtz and Hortsman, Kiel and Belcher all give themselves away. Then you, Heilner, let five of your men be shot out of the air and let five of our planes be destroyed by a tin Yankee soldier of fortune.

"Where is the deed and survey Wyndam gave to that Yankee scum Hassfurth? Hassfurth still has it. He can bring the French down on our heads at any time. And that will be the finish unless we strike first. And we're not quite ready to strike. Hassfurth and Barnes didn't land here to-day to wish us a Happy New Year. So far they've won every conflict we've had with them. So far we've kept under cover, and our actions under cover. The French officials are wondering about those five biplanes and the bomber you landed here to-day. If Barnes goes to them with his story they'll be up here with an army in twenty-four hours."

"And where will that get them?" Heilner sneered, his hideous face contorted. "We can blow their army into the sea."

"But what will that get us?" Zimmerman raged. "They'll withdraw and send for reinforcements and an air force. We'll have only this plateau. They'll cut us off from supplies. We must strike before they come here. We must drive them out of the capital and seize it and the railroad to Tamatave and Fort Dauphin. And the naval station at Diego Suarez. We must gain complete control of the island and declare Cistra the queen and descendant of Queen Ravalona III. We must have all of the natives armed and ready to fight when the French come back.

"There is only one way to hold them off. We must get that deed from Hassfurth. Then the French can't prove

that this plateau hasn't always been ours. We can lay our plans carefully and be sure of success when we are ready. We have a fortune invested here but we can win it back a thousand times if we proceed carefully. We must eliminate Hassfurth and Barnes in such a way that suspicion will not be directed at us!"

Cistra Boettner pushed back her chair and got to her feet. She covered her white face with her hands as though to shut out the evil faces before her.

"More murder!" she sobbed and ran from the room.

The three men watched her go without a change of expression.

"You're sure she'll behave when the time comes?" Zimmerman asked Boettner. The blood vessels bulged on Boettner's high, Teutonic forehead.

"She'd better behave!" he said, ominously. "I'll answer for her."

The three men put their heads together, talking so quietly that their voices could not be heard five feet away.

WHEN Bill and Shorty returned to their hotel, they ate what the hotel called supper, in the company of Red, Cy and Sandy. After Bill had told them what Shorty and he had discovered that afternoon, and of their talk with the American consul, they discussed plans for the next day.

When they arose from the table Sandy's face was a thing of despair. Like the rest of them he had hardly touched his food. The heat and the nature of the food and the dirt of the hotel was too much for all of them. The sooner they left here the better.

"I hope Charlie will have something decent to eat on the transport to-morrow," Sandy said.

They all went to their rooms and fell into a deep slumber.

When Shorty suddenly awakened he remembered that night back on Barnes

Field when he had awakened to find some one searching his desk.

He was possessed with the same awareness now. A minute or two went by and he could feel the cold perspiration creeping out on his body. He shifted his position ever so little and slipped his hand under his pillow to get his automatic.

Silence. Stark, terrible silence. He wanted to shout, to leap up and close in with whatever was in the room. The thought of cold steel sent icicles running up and down his back. A board creaked in a corner of the room, and he trained his gun waiting for another sound.

Then a sharp explosion came from the room next to him, Bill's room. It was followed by another, and another. He could hear the soft *pat-pat* of feet and voices speaking in Malagasy in the hallway. He jumped from his bed, bending low and started toward the door. He heard Bill's voice in the hall and heard him pounding furiously on the door.

Hands and arms suddenly closed in on him from all sides. Bands of steel encircled his wrists and pushed his gun downward. His finger contracted on the trigger once before it was torn from his grasp. A hand covered with a rag was clapped over his mouth and nose as his arms were twisted behind his back. He kicked a man in front of him in the stomach with his bare foot. One arm slipped free and he swung his fist wildly. It cracked on something soft. A voice groaned and cursed in a language he could not understand.

Then his unseen enemies were all over him, beating him down, smothering him. Half a dozen hands closed on his throat and neck. His senses began to reel from the sweet, nauseating drug that was pressed against his face.

Bill's shouts and plunges at the door became fainter and fainter as his desperate struggles diminished. Every-

thing seemed to explode in his head. He could feel himself being lifted into the air to float away into space—

When Bill burst through the door with an automatic in his hand and a half dozen native hotel attendants behind him, the room looked as though it had been visited by a Kansas tornado.

Clothes, shoes, chairs and tables were scrambled together. In two places Bill found little pools of blood, and he swore softly between clenched teeth.

As Sandy and Red and Cy joined him he found a rope ladder that hung out of the window from hooks caught under the sill. The ladder dangled to a sloping roof ten feet below, from which there was a clear drop of another ten feet to the courtyard.

By the time Bill got down the ladder no sound was audible in the courtyard. It had only been a matter of a few minutes since he had heard some one opening the door of his room. He waited until he thought the door was half open then he had reached for his automatic and poured three shots at it in the dark. He had heard a stifled scream and the door had banged shut before he could get to his feet. When he rushed into the hallway it was to find it dark and empty except for a few hotel employees who had been aroused by the shots and were tearing up the stairs toward him. They had heard the terrific scuffling in Shorty's room and had tried to burst in the door. But they had been too late.

Bill crouched in the little courtyard of the hotel trying to pick out the dim obstacles before him in the darkness. The attack had taken so little time and had been so perfectly executed he was still half dazed.

One circuit of the courtyard convinced him that Shorty had been taken through the gate. He sped through it as Red and Sandy joined him. He ran down an alleyway with the cobblestones

bruising his bare feet. A mangy, slinking dog was the only thing he encountered.

Shorty had disappeared as completely as though a hole had opened in the earth and swallowed him up. It was incredible and terrifying. The Frenchman who ran the hotel came running toward him with two native policemen.

They had not seen a group of men. They had heard the shots and had run into the hotel, the policeman said. No, they hadn't met any one—

"That's when they got out," Bill said, viciously.

The police put a dragnet around the block, searching each house systematically. Bill and his men watched them with sardonic eyes. But Bill didn't give them any further information. He told his men to get dressed and ordered a cab to take them out to the field where they had left their planes the afternoon before.

He had given old Charlie instructions to refuel the transport, the Scarlet Stormer and the Snorter. The Eaglet was already carrying a full load of fuel.

When at five o'clock the Betsileo guide reported to him and the police had found no trace of Shorty, Bill ordered his men into the cab. He had heard the far-away drone of a multimotored plane soon after Shorty's disappearance. He knew that plane was carrying Shorty, or what remained of him, into the hills beyond Ankazobe—

THE FIRST THING that came to Shorty's ears when he woke was the far-away beating of drums and the chant of human voices. He opened his eyes wide and gazed about him.

When they had become accustomed to the dim light he saw that he was lying on a hard wooden cot in a high-thatched hut. The room had a narrow door at one end and a barred window at the other. At the door sat a nearly naked

native with a rifle across his knees. That was all Shorty saw with his first glance, because he had to close his eyes from the pain that racked him in every muscle and joint. He ran his tongue over his lips and groaned as some one daubed at his temples.

When he opened his eyes again it was still dark. Rude gum flares threw grotesque shadows about the room. Peering intently he could see that the native with the rifle was still sitting cross-legged before the doorway.

"Ho!" Shorty called, weakly. The guard turned his head, his features impassive. Shorty made a motion of picking up a cup and drinking. After a moment of indecision the guard got to his feet and poured him a gourdful of water. He consumed it in great gulps and asked for more. When he had finished it he laid back with his eyes wandering about the ceiling.

The distant beat of tom-toms came to his ears again and the wild cries of hundreds of human voices swelling to a frenzy, then falling away in a staccato chant. The glows from many fires lighted the heavens outside the narrow door and twisted the long rows of thatched huts and brick buildings into fantastic shapes.

Suddenly a voice sounded from a bunk at the other end of the room. A bunk Shorty had thought was unoccupied. The diction of that voice and the way it spoke chilled Shorty's body as though he had suddenly been shaken with fever. His mind flashed back. Memories floated before his vision like an unreal, fantastic procession of time. He pressed his finger nails into his body to see if he was dreaming. The voice came again. A voice he had known a million years ago. For a moment something cataleptic held him motionless. He could not move. Commanding all of his will he slowly turned his head.

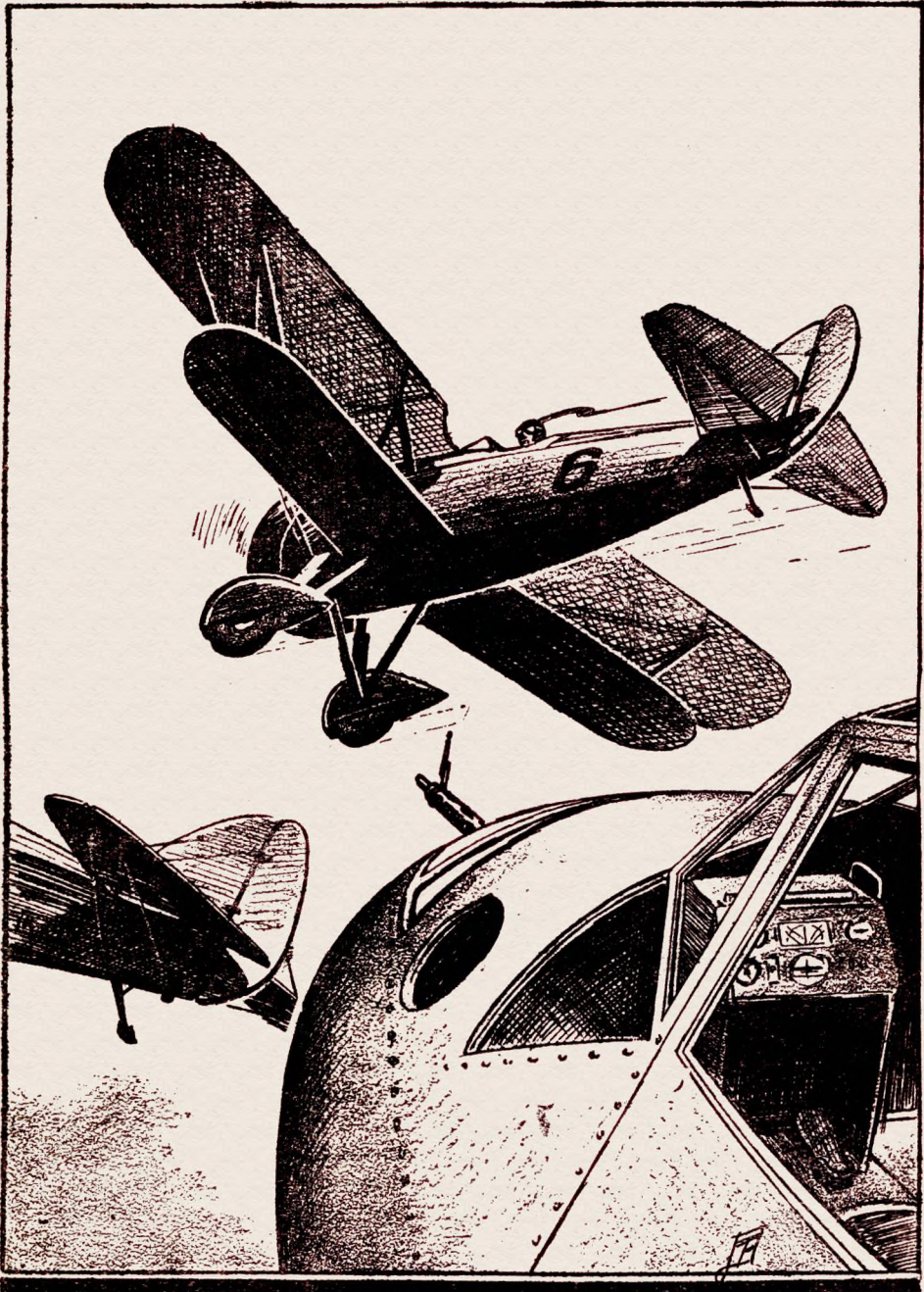

Two of the enemy planes hurtled down on the tail of Red Gleason's Snorter. Their bullets ripped the air above his head.

"What-ho, old bean," a smiling English voice said. The words came from a man who could barely raise his head from the bunk where he was secured. But in the flare of the fires outside Shorty could see that the man had fair complexion and hair. He struggled to get control of himself as he gazed at the head of the man who smiled at him.

That smile came back to him after seventeen years. He remembered that last smile of Virgil Wyndam before Wyndam had died behind the German lines. He had remembered it through all those years and now he saw it again. He could only stare. He tried to speak but no sound came from his throat. He wet his dry lips and tried again.

"Is—is that you Wyndam?" he asked.

The man's head came up a bit farther. His eyes widened.

"Who are you?" he asked.

"Hassfurther. Shorty Hassfurther." That was all Shorty said. He didn't dare say more. He knew that if he saw what he believed he saw the other would know the rest.

A laugh like the laugh of his old major came to Shorty's ears as the man threw back his head.

"Fancy seeing you here!" he said. "I'm Wyndam, all right. Or I was. Dick Wyndam, Shorty. How in the name of all that is holy did you get here?"

Shorty fell back on his bunk for a moment. He felt weak and dizzy. For a moment he had believed that he was looking at his old major alive and partly sound. It was almost too much for him. Miracles like that didn't happen. But he had found Dick Wyndam. That was the thing he had come for. He knew he must tell Wyndam quickly why he was there before some one stopped him. Painfully, he pushed himself up on his elbow.

"I came out here to find you, Dick,"

he said. "I had a letter from your father. He said you had disappeared. He thought I might be able to find you or know something about Virgil's land here that would help the English officials find you. Bill Barnes came with me. We landed at the capital yesterday.

"I came when I found some papers Virgil gave me the day he died. I stuck them in the pocket of a tunic that day behind the German lines and forgot them. Your father's letter and sheer chance brought them to mind. I dug them out."

"The deed and survey of Virgil's property?" Dick asked, his voice strained.

"That's right," Shorty answered. "So I came out here with Bill and a couple more of his men to see what we could do. Some one overpowered me last night and brought me here. Some one who is after the deed. Do you know who it is? Who brought you here?"

"Three Germans named Boettner, Zimmerman and Heilner," Dick said. "They picked me up almost as soon as I landed. Heilner is one of the men who shot Virg down that day. Virg wasn't dead when they landed beside him. He regained consciousness and babbled to Heilner about Madagascar and about you. Heilner found a diary in his pocket that told him a great deal. He got Zimmerman and Boettner to back him. They came out to investigate.

"Since then they have spent a fortune here because they have learned how valuable the island is. They are all madmen. They have organized the natives and brought in artillery, anti-aircraft guns, fighting planes, hundreds of machine guns and rifles. They intend to seize the island. When they have control, under a smoke screen of a native uprising, and by putting Boettner's niece on the throne as a descendant of Ravalona, they expect aid from a powerful European country to hold it.

"They have threatened time and again to kill me. Only the intervention of Cistra, Boettner's niece has kept them from it. I've been a captive here for three months. Lying here rotting. Only Cistra's spirit and courage has kept me alive. They are madmen, Shorty."

The guard at the door got to his feet quickly and came to attention. The questions that were racing through Shorty's mind were entirely forgotten as the form of a man in glittering uniform loomed in the doorway, crossed the room and stood above him, a soft, sneering laugh on his hideous face. Across his chest were pinned a half dozen medals. His massive shoulders seemed to droop beneath the weight of braid and gold buttons on his uniform.

"Well, you Yankee pig," the man snarled, "we have the great mutual pleasure of meeting again. And in the company of the brother of the man with whom we last met."

Shorty's eyes widened and his mouth came open as he stared up into that cruelly scarred face above him. His voice was only a whisper when he spoke.

"Heilner!" he said. "Captain Eric Heilner!" He blinked as though he couldn't believe what his eyes saw.

"Yes, Heilner. But General Heilner now!"

Shorty laughed. He couldn't have helped laughing if his very life had depended on his not laughing.

Heilner's face went purple with rage and his hand went to the automatic strapped around his waist. Then he got control of himself.

"We've searched you and we searched your room before you awoke," he said. "But we didn't find what we want. You have one chance of living, Hassfurter. Just one. Tell us where that deed can be found and join us as commander of our air force and you live. You will become wealthy. You have everything to live for You——"

Shorty threw back his head and laughed until he had to stop because of the pains in his bruised body. The man was a maniac.

"When the French come up here with a few 75s and a regiment of legionnaires," he snapped, "your natives will run themselves to death."

It was Heilner's turn to laugh now.

"What are a few thousand French swine compared to a million natives?" he asked. "We're here to take the gold out of this place. When we are through the natives can have the island. I am not going to beg you for that deed. I will give you an opportunity to think over my suggestion. Until noon. If you won't talk then, both you and young Wyndam die!"

XII—GRAY FIGHTERS

THE ATTITUDE of Bill Barnes and his men was changed from that of the day before when they climbed out of the cab beside their planes.

Bill's face was grim and unsmiling as he went over the monster transport, carefully checking and rechecking the engines, ammunition and guns.

"You'll probably need your bombs today, Bailey," he said to the grim-lipped, young gunner in the forward cockpit.

"They're ready, sir," Bailey replied.

After Bill had carefully checked all of the planes he called his pilots and gunners into the transport. He stood before them on the steps leading to the bridge. His bronzed face was lined and white underneath his tan. His eyes and lips were hard and unsmiling. He raised one hand for silence.

"We're going after Shorty, men," he said. "And we're going to get him. This is the third time they've tried to get him and this time they've succeeded. We're up against a band of dangerous killers. I want you all to shoot straight. Make every shot tell."

"I'm going to lead you in the Scarlet Stormer. Red will fly the Snorter, Cy the transport. McCoy, you'll have to be ready to take over the controls in the transport if anything happens to Cy. Neely will handle the rapid-fire gun because I want Sandy to launch the Eaglet as soon as the transport is in the air.

"We'll probably have five fast single-seater fighters against us. And a twin-motored bomber that is armed to the ears. What else I don't know. But watch out for anti-aircraft guns when we reach our objective. I'm expecting every one of you to give everything he has for Shorty."

He stepped down off the step among his men. They all hurried to their stations. They had an unpleasant job ahead of them and they wanted to get at it.

Fifteen minutes later the red comet that was the Scarlet Stormer roared into the air with Bill Barnes' hand wrapped around the control column. It was followed immediately by the equally red Snorter. They circled above the capital until Cy had joined them. Then Bill threw the radio switch in the Stormer.

"I'll go to eight thousand feet," he said. "Cy, you hold her steady at five thousand, just below me. Red, keep parallel with the transport on the port side. Break out the Eaglet, kid, and take a position on the starboard side of the bomber."

Sandy required no urging. It was the first time he had taken the Eaglet out of its flying hangar since they had left Long Island. His eyes were shining in anticipation as he hurried down the steps from the bridge and along the runway beside the Eaglet.

He clambered into the cockpit and strapped himself. When he flipped up his hand a few minutes later Miles worked the mechanism that opened up the bottom of the mid-section of the fuselage. A long, latticelike crane low-

ered the small, single-seated biplane smoothly and quickly down through the aperture.

The tiny plane hung suspended, gently swaying back and forth from the force of the transport's engines. The wings snapped out and locked as Sandy manipulated a crank. The prop became a whirling disk as he worked his starter. After ten minutes Sandy signaled to Miles again. The hook released the little fighter and Sandy took it away in a long, fast glide.

As it came out of the glide he brought the stick back and brought the ship over in a tight, flashing loop. It rolled dizzily from side to side, did a split S and a chandelle. He brought the ship up in the first half of a normal loop and from an inverted position at the top half rolled the ship level in a flashing Immelmann turn.

He put the little biplane into a climbing turn until it almost stalled, let the nose fall away while he continued to turn. During the ensuing glide he brought the ship back to an even keel and executed another wing-over from the opposite direction. After a controlled spin Bill's voice roared in his ear over the radiophone.

"All right," he shouted. "Fasten your ears back and get in formation."

"I'm just getting the kinks out of her back, Bill," Sandy replied. "She told me she had bed sores from lying in the hangar."

"Shut up and get back there," Bill barked.

Sandy flashed back to a position on the starboard side of transport. His face was wreathed in smiles. He was happy for the first time since they had taken the air at Barnes Field. That is, completely happy. If it hadn't been for the disappearance of Shorty he would probably have emulated Red Gleason in song.

Red was flying his Snorter with the

same grim purposefulness Bill Barnes was using in the Scarlet Stormer. He had not said much about the disappearance of Shorty. But his silence was eloquent. He and Shorty had been pals since those grim, gray days of War, real pals. For once in his life he was not singing as he studied the map spread out before him and checked his bearings.

Bill's voice came over the radiophone again talking to Cy Hawkins in the transport.

"You follow the guide's directions, Cy," he said. "I'll stay a little back, about three thousand feet above you, and follow your course. Can the guide make out the country below him from the air?"

"He's a wiz, Bill," Cy drawled. "We ought to take him on as an observer. He's picking out landmarks as though he had flown all his life. He says he has a very good idea of just where we'll locate Heilner's headquarters.

"He tells me he has heard rumors and whisperings about armed natives preparing for a revolt. He knows more than he's telling me, too."

"Pump him if you can. Can he understand what you're saying to me?"

"He's out of hearing now. What do we do when we locate the place? Dive in and let 'em have it?"

"Hold everything until I give the word," Bill said, sharply. "I'll be able to locate their fort before you can see it. I'll give you the sign when I've looked it over."

THE three planes swept above plains over which moved enormous herds of humpbacked cattle guarded by half-wild herdsmen and shaggy, savage dogs. Lemurs, civets and occasional wild cattle skulked in the bushes along the Tananarivo-Ankazobe road. The natives they saw from the air were more primitive than the ones around the capital. Most of them carried formidable-looking

spears and wore only a *lamba* wrapped around their waists. A funeral procession wound along the streets of a native village built on stilts and entirely surrounded by giant mimosa bushes. The natives were well filled with *touka*. Attired in their long, flowing *lambas* they danced the corpse to its last resting place.

A few minutes after they altered their course to the west, the first rim of jungle appeared. As the jungle grew denser and thicker the trail the Betsileo told Cy to follow became more narrow, winding steadily upward until the dense tropical foliage gave way to a short, stubby growth of bush, and then, near the edge of a plateau, became a mountain of giant boulders.

Bill Barnes spiraled downward as he saw antlike forms that were men milling about in an inclosure close to the edge of the plateau. He took a position in front of the carrier-transport and spoke to Cy over the radiophone.

"Follow me," he said, sweeping lower and lower. Suddenly, the whole plan of the fortifications and guns and planes took form below him. He realized that he was gazing down on a citadel that was armed to the teeth. Off to the right he saw a road that had been cut through the jungle to within a few yards of the edge of the flat land along the Tananarivo-Ankazobe road. That explained how the three Germans had got the guns he saw in the fort up through the jungle. They had brought huge cases, so the French officials had told him, of machinery to Majunga on the west coast, and up the Betsiboka River as far as Maevatanana. There it had been loaded onto trucks and taken to the foot of the jungle road he saw below him.

His eyes narrowed and he shook his head incredulously as he gazed down on the rows of mountain howitzers, anti-aircraft guns and long-range guns. The inside walls of the fort, literally, bris-

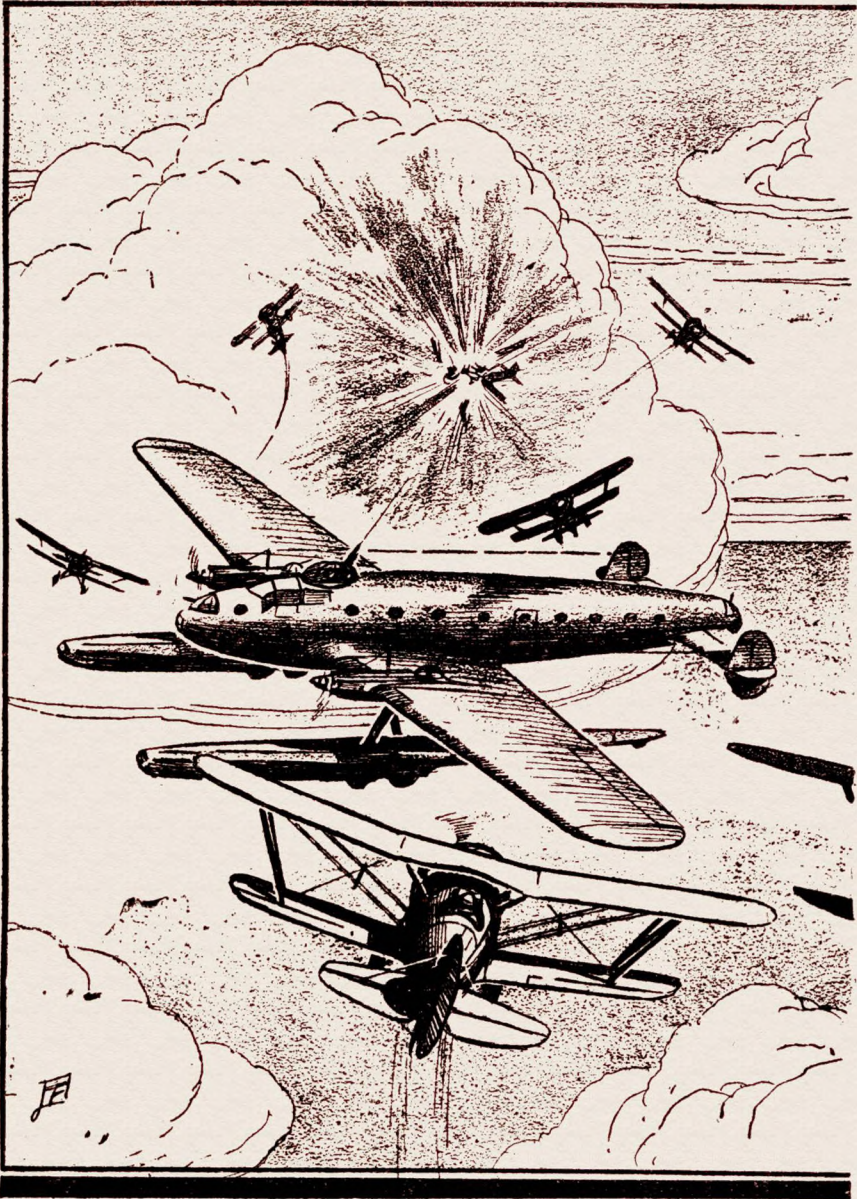

tled with machine guns. On a flat field near the gigantic doors stood two huge tanks, armed with field guns. A little farther along was a crudely built hangar that bustled with activity. Five of the rugged little fighters that had attacked them over the Mediterranean were being

warmed up in front of it. Also, a huge bomber with two big, air-cooled radial engines in the leading edge of the giant monoplane's wings. It was designed for use as a heavy bomber, for photographic-mapping work, ambulance service, troop or cargo transport.

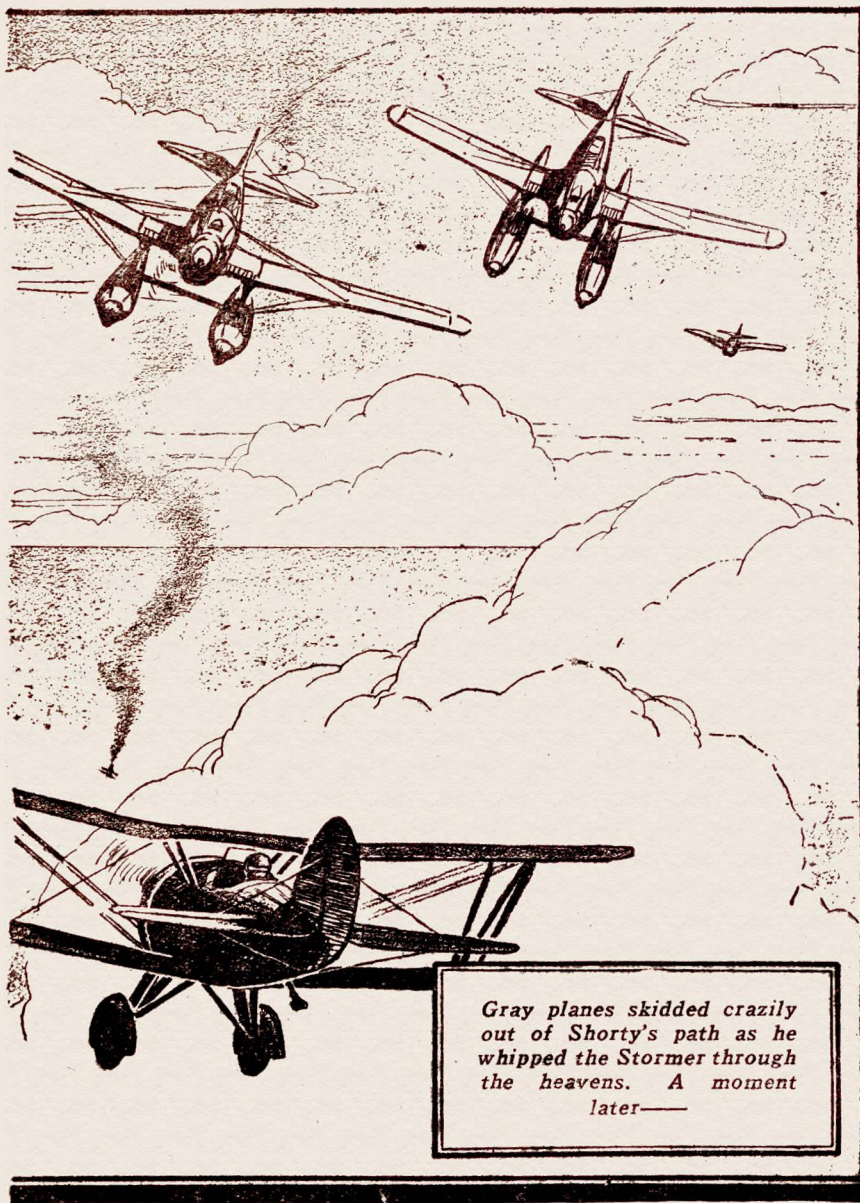

In the belly of the fuselage a machine gun could be seen pointing downward. A sliding hatch on the top, in the tail structure, showed another machine gun. On either side of the angular-shaped windows on the sides were swivel machine guns mounted in the sills. For-

ward, in the bombardier's cockpit, another gun protected the ship from frontal attack. Like his own monster transport the bomber was a flying fortress except for the rapid-fire.

Thousands of natives drilled on the flat plateau behind the fort. Each was

armed with a modern automatic rifle. As they fell into a long line of fours and started at double time toward their barracks Bill suddenly realized what he was up against. His breath hissed through his nostrils as he drew it in quickly. It didn't seem possible that he could have found such an organization in the heart of what was supposed to be a civilized protectorate. Within its very bosom France was harboring a secret force of greater strength than its own. A force that was slowly preparing to destroy it.

It came to him with a certainty that was not pleasant that Sturgis Benton, the American consul, had been right. The thing was bigger than any individual. What chance had he to rescue Shorty—if he were there—from such a place? The men crowded around the anti-aircraft guns in the fort answered his question. They answered it with a decisiveness that was unmistakable. A puff of blue-and-white smoke appeared close to him as a gun roared below. The shell burst close to him. Too close. Pieces of screaming shrapnel drummed through his wings and tail. The Scarlet Stormer was buffeted like a leaf in a high gale. The whole battery of anti-aircraft guns suddenly exploded.

He fought his controls and roared into the microphone as he saw Sandy's Eaglet stagger like a thing mortally wounded.

"Swing clear and get your ceiling," he roared. "Stick together. I'll lead the way."

The rataplán of the five gray fighters on the field below joined the roar of their engines as they took their ships upward in tight spirals.

Red Gleason cursed angrily as his Snorter was thrown about like a cork in an angry sea. "Those babies may be black but they can shoot," he told himself.

At ten thousand feet Bill leveled off

and waited for the other planes. Sandy was riding the Eaglet in a way that brought a gleam of pride to Bill's eyes. Sandy and the little fighter were as one. He came spiraling upward as though the devil was on his tail.

The enemy gunners below were blazing away with shell after shell. But they had lost the range now.

Bill threw over the switch on the radiophone and spoke again. His voice was excited. His eyes sparkled as he gazed down on the scene below him.

"Listen, Cy," he said. "Do you see the large brick building that looks as though half of it was buried in the ground—the round one near the center of the fort?"

Cy answered in a moment that he had located it.

"That, I think, is their magazine," Bill said, excitedly. "Ask Bailey if he thinks he could hit it at five thousand feet going two hundred miles an hour."

The radiophone was silent for a moment. Then Cy's voice sounded again.

"He says he can try," Cy reported, calmly.

"All right," Bill said. "Get down there and let them have it."

SANDY hadn't been listening to the first part of that conversation between Bill and Cy. He had slipped his helmet back off his head for a moment and consequently missed it. But he heard the last part. He heard Bill say, "Get down there and let them have it."

That was enough for him. As Cy circled downward, varying his speed and direction slightly to throw off the aim of the gunners on the ground Sandy jammed the control stick of the Eaglet forward. Sunlight flashed on the metal surface of the wings as Sandy pointed the nose of the Eaglet earthward in a vertical power dive.

Bill's fist clamped around the control

column of the Stormer until his knuckles showed white when he realized what Sandy was doing.

"Pull her out, you little ape!" he belted into the microphone. "Pull her out!"

But the little ship went plummeting down and down with Sandy standing almost bolt upright on the rudder bar, his hand wrapped like a band of steel around the stick.

Then his arm came slowly back. The nose came up, higher and higher. The baffled wind shrieked and screamed through the stout bracing struts as Sandy peered through his hair sights. He stuck the nose down again, directly at the group of men throwing shells into the breeches of the fast-firing anti-aircraft guns. Malignant puffs of smoke had followed in his wake on that terrific dive.

Now the guns became silent as Sandy's fingers clamped around his gun trips. Men ran, screaming, in all directions. His bullets raked the ground viciously. Men fell like tenpins under the hail of lead and tracers. Machine guns along the walls of the fort began to stutter. The anti-aircraft guns were useless against him because of his low altitude.

The machine guns directed at him were ineffective because of his tremendous speed. His own aim was devastating. He leveled off a bare two hundred feet above the ground. Machine-gun bullets drummed through his wings, crashed through his tail structure, ripped into the tiny cockpit. Perspiration ran down under his helmet and into his eyes. Men ran about on the ground like rabbits trying to escape his fire. His eyes were gleaming, his breath coming in short, agonized gasps.

Looking up and back he saw that Cy had brought the big transport down directly above the cluster of buildings in the fort. He pulled back on his stick

and zoomed upward as he saw a small opening appear in the bottom of the bomber and a small egg-shaped projectile start its murderous journey toward the ground. Dust and dirt, bricks and stones flew in every direction as Bailey sent three of his bombs into the fort. Men dropped like tenpins again, folding up where they stood.

Sandy fought the Eaglet as it bumped through the air. Then he dove toward the crude hangar and the five gray fighters about to take the air. Again his bullets sent men running in all directions. Laughing to himself he zoomed upward as he saw Cy circling back to drop more bombs. The place was a madhouse now. Bugles blared. Men shouted orders. The *tat-tat-tat* of machine guns blended with the roar of airplane motors.

Again the big bomber dropped a load of death and destruction. But there were men back at the anti-aircraft guns now. Puffs of white-and-blue smoke appeared in Cy's wake as he zigzagged the unwieldy bomber across the sky to avoid being hit.

As Sandy saw the first of the enemy planes speed across the turf and take to the air he again went into a dive. The air was interlaced with machine-gun fire. But in some manner that was beyond understanding he got through it. As the gray plane rose from the ground Sandy poured round after round of lead into it. It wavered at fifty feet and slipped off on one wing. The pilot slumped over the cowl as the little gray fighter stuck its nose down and crashed into a clump of trees.

Sandy circled and waited for the next plane to take the air. Then he saw two machines take off at once in different directions.

Bill Barnes, coming to Sandy's assistance, saw them, too. He knew that Sandy could not be in two places at one time. While he shot down one of the

gray fighters, the other one might get him. He shouted into the microphone. His face was white, his eyes blazing.

"Come out of that, Sandy," he roared. "Come out of it you half-wit, before they have to shovel you off the ground!"

But Sandy didn't come out of it fast enough. The first two planes were followed into the air almost immediately by the second two. They were up and under Sandy's tail as he started to run away. All four of them closed in on him. He whipped the little Eaglet around in a flashing Immelmann and tried to climb away from them. They were like a flock of vultures.

Suddenly Sandy whipped over and flew back toward the circling biplanes. White streamers cut through the sky as the first biplane fired. At that instant Sandy did a complete roll, turned left and came up above that first gray fighter. He half rolled and dived with his guns chattering. As the biplane veered away he whipped about in a vertical spiral.

He rolled and twisted desperately to get out of range of the guns of the other three planes. They lined up and began to circle about him again to get him in the vortex of their fire. Bill Barnes cursed as he saw what the gray fighters were going to do to Sandy.

THEN, as Bill knew the leader of the three biplanes was about to open up a cross fire from which there would be no escape, Sandy pounced forth and attacked another of the biplanes. He flew straight at it with both guns chattering. The deadly hail of lead tore the pilot's head from his shoulders. The biplane went into a sickening whirl as Sandy zoomed upward. The sky was full of smoking lead. The little Eaglet staggered and dropped into a side slip as the three planes sat under Sandy's tail and poured lead into it.

Then Red Gleason and Bill tore the alignment of the three planes to bits.

They dove on two of them and raked them with lead. They were like two mad bulls as they whipped their planes through the sky. The three biplanes zoomed, dove and darted in every direction to escape those two whirling derbies.

As Bill saw Sandy straighten out the Eaglet and limp away to the west he shouted into the microphone again. "Get out of this, Sandy," he said. "Cy, stay with Sandy. He's almost out of control."

The anti-aircraft guns opened up their fire again as Cy winged back overhead. Machine guns belched fire and lead and tracers at the two red planes above them.

Red Gleason was trying to sing. The blood was racing through his body like fire. He was half around in a vertical back when a gray fighter zoomed upward beneath him. The twin guns mounted along its engine housing spewed out burst after burst of fire. The lead chewed through the leading edge of his left wing. He threw his ship out of the line of fire.

The biplane roared upward and dove back to the attack. Red pulled his stick back and raced up to meet the diving plane. The two planes roared at one another with terrific speed. Red's fingers tightened on his gun trips. His guns chattered the song of death. His bullets drove through the biplane's fuselage before the pilot threw his ship out of range.

"That baby can handle his ship," Red muttered to himself, his face contorted with rage.

The two ships streaked and tumbled all over the sky, filling the air with red-hot lead. They fired burst after burst at one another without telling effect. Far off to the left, Bill Barnes was fighting the two other gray planes. He was flashing through the sky in a series of lightning acrobatics that prevented

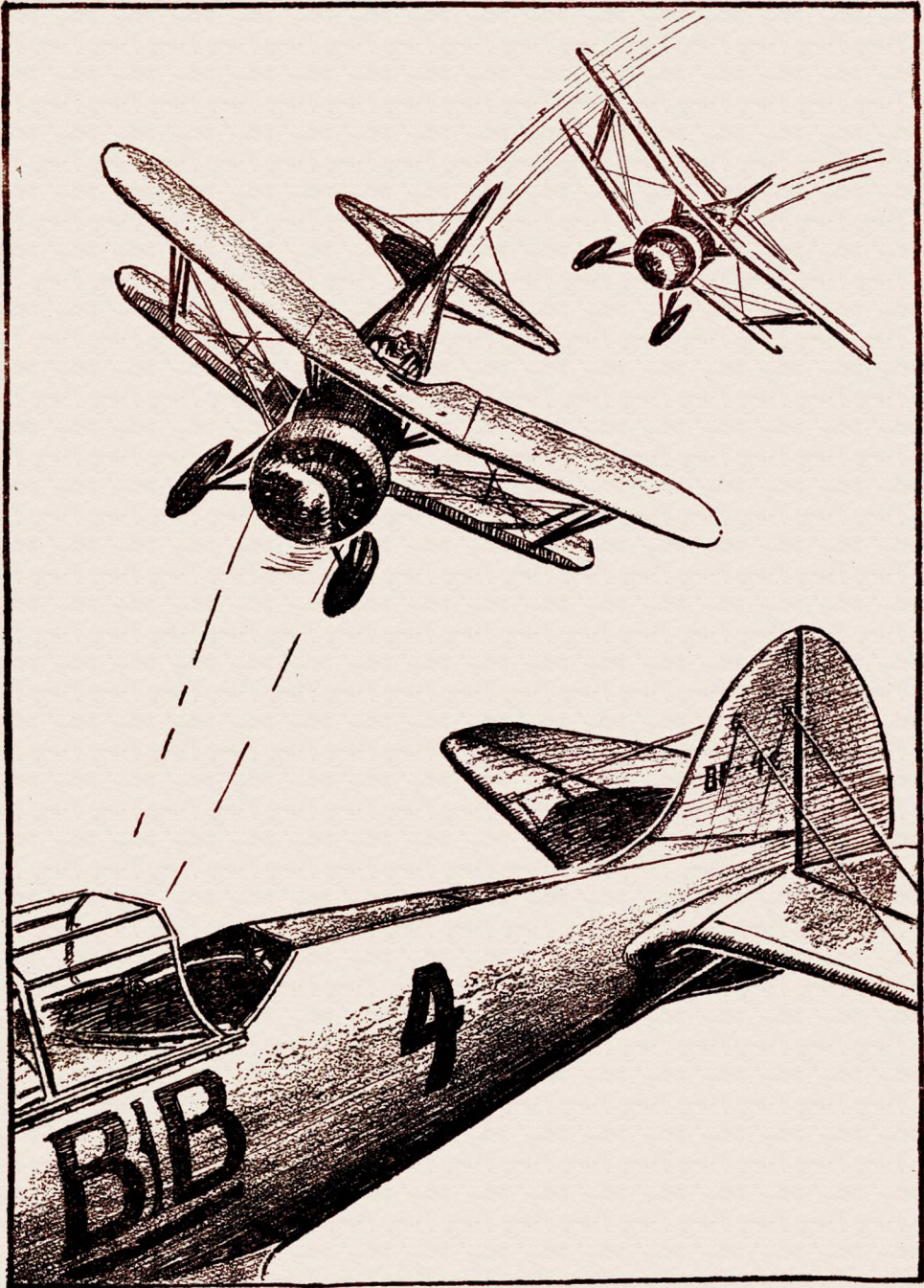

The bullets from the gray planes ripped the air over the Snorter. The Snorter turned suddenly— Smoke billowed from the enemy's engine. The pilot dived—

the two gray fighters from touching him. He was dodging their bullets while he maneuvered to get them under his guns.

Red Gleason's teeth were clenched now. He was giving everything he had to get the man with the hideously scarred face who was piloting the enemy ship. None of his tricks seemed to click. The other pilot escaped from every trap he laid for him. He seemed to bear a charmed life.

Then it suddenly came to Red that the other man was a master craftsman. He was slipping away from Red's vicious attacks with the ease of an artist. For a moment Red almost lost control of himself. His lips became a hard, set line of determination. His red hair fairly burned beneath his helmet. He used all his powers of concentration as he realized the enemy pilot was luring him closer and closer to the ground and into the range of the machine guns in the fort.

He saw Bill Barnes send a hail of lead into one of the planes below him. He saw the plane burst into flame and careen drunkenly toward the earth. He saw the other plane turn tail and scoot toward the protection of the hangar. All those things, he saw. And he heard Bill's voice in his ear over the radio-~~phone~~. He heard Bill order him to follow Sandy.

But he couldn't obey. The only thing that really penetrated his consciousness was the enemy before him who seemed to be laughing at his attempts to shoot him down. The man's skill was uncanny. A dozen times Red thought he had him in a position from which there was no escape. But when he clamped down on his firing trips the plane disappeared from under his sights as though some unseen hand had flicked it out of danger.

Perhaps, he thought, this is the man Shorty spoke about. The man who killed his friend Wyndam. Who almost

killed Shorty. Perhaps he had killed him now. The thought brought back Red's sanity. He realized that in his intensity he was doing the very thing he had taught other men not to do. He was "freezing on his controls." He was trying too hard.

The next time the gray biplane flashed across his sights he kicked his rudder ever so little as his fingers gripped hard on his gun trips. The nose of his Snorter followed the course of the gray plane for a split fraction of a second. Red's bullets wove a pattern from the engine housing to the tail structure. The gray fighter skidded off dangerously on one wing and yawed wildly. Red whipped the Snorter over and returned to the attack. His breath was coming in short gasps now. He poured round after round toward the other plane as it dove for the earth below.

Red felt his Snorter tremble and buck as it was struck by machine-gun fire from the ground. He pulled back on his stick and zoomed upward. He ground his teeth as he saw dust rise from the earth when the gray plane struck the ground at a steep angle, nearly nosing over. But it didn't nose over. The pilot fishtailed the rear skid around in some way and came to a halt.

The pilot stepped over the side and dropped to the ground as Red opened the throttle of the Snorter wide and roared away after Bill.

Red could not help one more glance backward. His whole body steamed with rage as he saw the pilot walking away from his plane, unhurt. It was too much for Red. He didn't even know that anti-aircraft shells were bursting near by and machine-gun bullets were tearing through his already perforated wings.

It was more than his pride could stand.

"I'll be back after you, tough guy," he ground out between clenched teeth.

XIII—RE-ENFORCEMENTS

RED cut his engine and swooped to earth beside Bill's Scarlet Stormer, the transport and Sandy's Eaglet. One glance told him that the little Eaglet had been perforated with machine-gun bullets. The dural wings and tubular steel fuselage resembled a sieve for straining vegetables. The extra gas tank beneath the fuselage had been drilled by a half dozen bullets. The rudder had almost been torn from its post.

Sandy stood regarding his ship with something akin to tears in his eyes.

"Gosh, Bill!" he said. "They certainly shot my buttons off!"

"It seems to me," Bill answered, gruffly, "you didn't do so badly by them. You not only shot the buttons off two of their ships. You completely undressed them. They'll have to use 'em for kindling."

Sandy's face brightened. Even that much praise from Bill was something to cherish. His boyish face became wreathed in smiles. Suddenly the smiles disappeared—as quickly as they had appeared.

"But we didn't find Shorty," he said. "I was worried about that when Cy began bombing them. Suppose Shorty was locked up in one of those brick buildings Cy tore out of the ground."

Bill Barnes didn't answer. He had thought about that, too. The thought had seered his mind like a contact with white-hot metal. He shook his head slowly from side to side.

"I didn't expect to run into anything like that place up here," he said. "I expected we might have some trouble with those gray fighters. But I didn't expect to run into a fort armed with all the modern equipment for offense and defense.

"We're right where we started and we haven't located Shorty," he went on, bitterly. "There is only one thing to do. But first we must get the Eaglet

back inside the transport if you think she'll hang together that long. I'll take the transport into the air and you follow me in the Eaglet."

"O. K., Bill," Sandy said.

Bill made sure that Sandy was wearing his parachute before he took the big transport off the ground in a long, low climb. Sandy followed a few minutes later. He leveled the Eaglet at three thousand feet and took a course directly behind and just below the transport.

"Take it easy, kid," Bill said over the radiophone. "Come in easy. Your landing hook may have been struck and weakened."

"Easy it is, Bill," Sandy answered. He brought the Eaglet up under the transport slowly. Perspiration oozed from Bill's forehead as he felt the monster ship tremble and buck. He fought his controls to hold it steady as the trapeze lifted the little fighter up into the bowels of the big ship. He breathed a sigh of relief as he heard the lifting mechanism stop and heard the underside of the fuselage slip into place.

A couple of minutes later Sandy fell into the port pilot's seat on the bridge. His face was grimy and black from powder smoke and perspiration. He shook his head slowly from side to side.

"What are we going to do now, Bill?" he asked. "One Snorter gone and the Eaglet useless. This has been a tough trip."

"We'll make out, kid," Bill said, easily. "I'm going to land beside the Snorter. We have two fighting ships left. But that's all our enemies have. When we get down on the ground I'm going to take Red and Cy, and the transport gunners, and do a little reconnoitering. You'll have to stay to guard the transport and the Snorter. I——"

"Gosh, Bill!" Sandy pleaded. "I'm all right. Why can't I go with you?"

"You've had enough to last you for

a while," Bill answered. "Some one has to stay with the planes."

Sandy fell into an abused and eloquent silence. But he didn't say anything more. He knew now that he had disobeyed orders and that he was being punished for it.

He sat back in the pilot's seat of the transport a few minutes later and watched the rest of Bill's men disappear with him into the thick bush along the rim of the plateau. They all carried rifles and automatic pistols.

"They say they'll be back in an hour," he grumbled. "They'll probably never come back."

HE SAT listening to the awful stillness of the place for a matter of thirty minutes. Then he went down the steps to the guest cabin in the tail. From a duffel bag he extracted the pot-bellied, death's head dummy with which he had been practicing ventriloquism before he left Barnes Field. He grinned and carried the thing up to the bridge. He sat down in the pilot's seat again and slipped his fingers into the ends of the strings that manipulated the dummy's head, hands and legs. Then he began to talk to it. And it to him.

He forgot that he was on the island of Madagascar, twelve thousand miles from home. He forgot about everything but the dummy and their conversation. Sometimes he threw back his head and howled with laughter. Another time it was the dummy that did the same thing.

Then suddenly, he became aware of movement around the transport. He listened for a moment and heard the unmistakable sound of moving men. He got to his feet and edged cautiously toward the window, his hand wrapped around the butt of the automatic strapped to his side. Seeing nothing he went cautiously down the steps to the forward gunner's compartment in the

nose. Looking down through the glass in the bottom he saw a half dozen muscular, gleaming-black bodies beneath the fuselage. They carried long primitive spears in their hands and were naked except for the *lambas* wrapped around their waists.

Sandy ducked quickly out of sight and hurried noiselessly back up the steps. He stood on the bridge uncertain as to what he ought to do. Perhaps they meant to burn the transport. The thought sent him hurrying down the runway beside the Eaglet at the entrance door on the port side. Opening it cautiously he saw another group of natives clustered around the Snorter. They were not molesting it. Merely squatting beside it and watching it with intense interest.

He stuck the head of the dummy around the corner of the doorway and began to talk to it. The dummy answered him with bobbing head and gesticulating hands and feet. The natives underneath the transport and beside the Snorter gazed at the thing with wide, fear-crazed eyes. They didn't attempt to run away. They stayed where they were, rooted in their tracks.

Sandy made the dummy, by means of the strings attached to it, throw back its head, open its mouth and give voice to full-throated shouts and laughter. He kept up a fast-moving conversation that made no sense whatsoever.

It was when he was beginning to grow hoarse and weak from talking and throwing his voice that a shot sounded from the bush, and Bill and his men came charging across the short, tough grass toward him.

The natives threw down their spears and fell on their faces as they approached, emptying their guns into the air.

Sandy went down the folding gangway to the ground with the dummy still in his hand. The natives gazed at him

and at the dummy with rolling eyes. After Bill had looked them over he whirled on Sandy.

"What are you doing with that thing?" he asked.

"I was entertaining them," Sandy said, with a grin. "I heard them underneath the transport and had the dummy talk to them. I thought that if they intended to set it on fire I might hold their attention until you came. My gosh, I was scared to death!"

Bill glared at him and turned to the Betsileo guide who was talking to one of the frightened natives.

"What do they want and where did they come from?" he asked.

The guide's brown face broke into smiles at Bill's question. He pointed to the man to whom he had been talking and laughed.

"They're harmless natives from across the Betsiboka River," he explained. "They aren't part of that other crowd you were fighting. They saw big birds land here yesterday. He says they had never seen such large birds. And they saw men riding on them.

"When they saw you land they were hunting. They came here after you left to get one of the big bird's eggs. They think they are birds that lay eggs. They wanted to hatch one so that they can fly in the air on it."

Bill gazed at the Betsileo for a moment with an incredulous expression. Then he threw back his head and roared with laughter.

"You saved us all right, kid," he said to Sandy. "All they wanted was an egg. They think you're an Easter rabbit."

Sandy glared at the howling Red Gleason. Cy Hawkins was regarding Sandy with quiet, amused eyes.

"Scared to death of a few harmless natives out hunting for eggs," Red laughed.

"Aw nuts!" Sandy said and stamped up the gangway into the transport.

THE HIGH, shrill whine of shells racing overhead caused Bill and his men nervous moments as they inspected Red Gleason's Snorter. They found that it was in as bad, if not worse, condition than Sandy's Eaglet. Two control cables had been entirely shot away. The wings and fuselage had made contact with over two hundred bullets. Sandy counted the holes.

"I don't see how you ever got it back here," Bill said. "Or why you didn't stop one of those bullets."

"It's that silver five-franc piece with the hole in it he carries," Sandy said, scornfully.

Red grinned and dug one hand deep down in his breeches pocket. When he pulled it forth he spun a coin the size of a silver dollar high in the air and caught it with one hand.

"You tell 'em kid," he said. "That's been riding with me for eighteen years."

"It's the only thing you can get to ride with you," Sandy came back. "I'd just as soon ride on one of those shells as with you."

"Shut up!" Bill said, as a shell exploded not over three hundred yards away. "They're popping those shells down here at random, changing their range with every shot. But they're too close for——"

"Bill!" Sandy yelled, his voice rising shrilly. "There goes that big bomber into the air."

Bill whirled and followed the finger Sandy pointed. A few miles off to the east the enemy bomber was circling upward. Bill watched it for a moment. As it straightened out and took a course to the southeast he jumped toward the Scarlet Stormer.

"Hop in and unlimber the swivel gun, kid," he said to Sandy. "We'll look him over. Cy, you stay here unless I send for you. If I do, leave one of your

gunners here to guard the Snorter and bring Red along to handle the one-pounder."

Five minutes later he gunned the motor and took the Stormer into the air as though it had been shot out of a catapult. Climbing to fifteen thousand feet he took a course that carried him directly over the enemy fort. The place was alive with action. Tractors were wheeling guns into place along the

"Something is up," Bill said to Sandy over the interplane phone. He studied the place with anxious, worried eyes as he circled above it. An anti-aircraft shell exploded below him. Another to the right. The sun was too bright for accurate shooting. He knew that he was in little danger of being struck as long as he changed his course and speed occasionally.

"I wonder if they have Shorty down

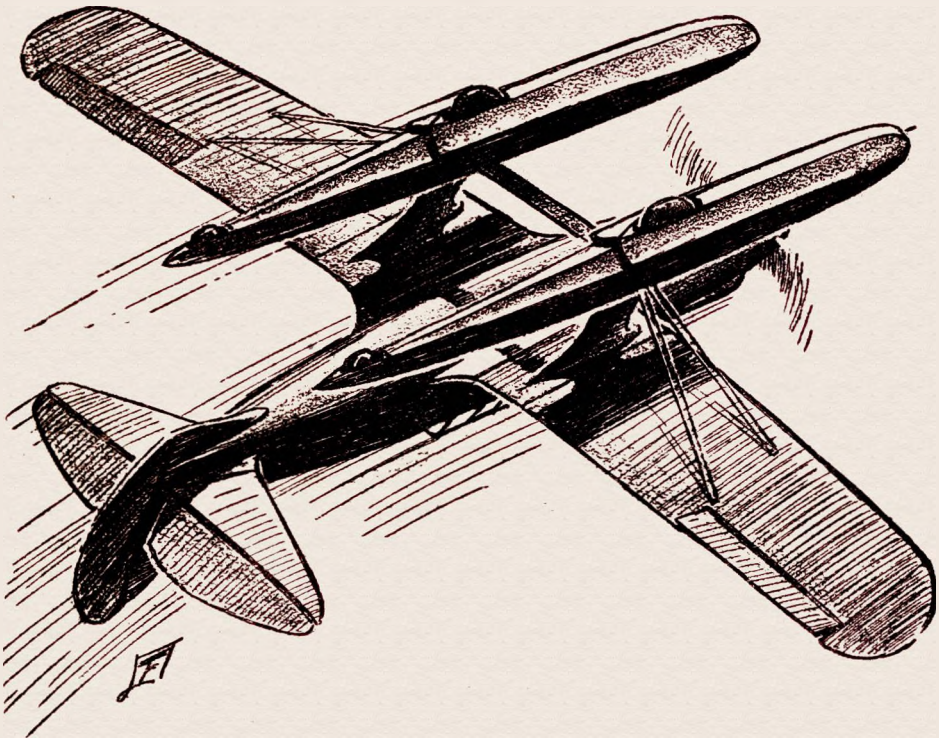

north and eastern sides of the fort. Black forms scurried in every direction. The place was a beehive of activity. Cattle were being driven into the inclosure from the plain outside. Men stood in columns of fours along the walls. Every machine gun along the inside of the fort was manned.

there?" he said, half to himself.

"There's no place else they'd take him, is there, Bill?" Sandy asked.

Bill shook his head impatiently. Angrily. He studied the place trying to devise some scheme to get into it. The thought came to him that he might get in alone disguised as a native. But he

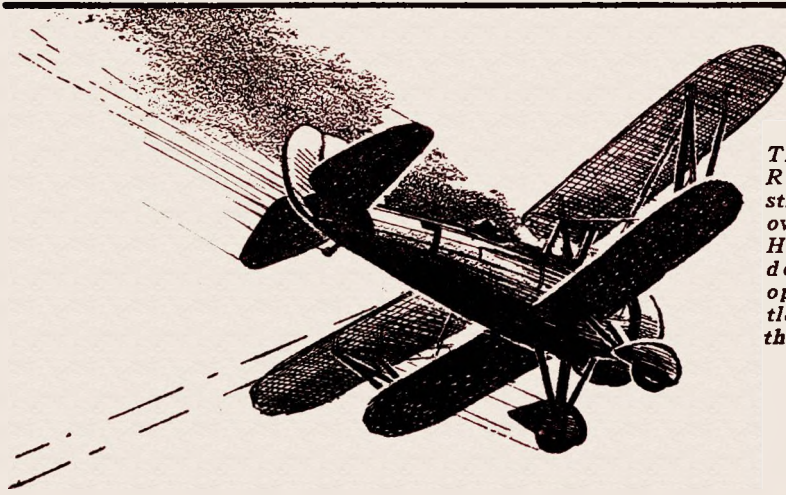

The next second Red jerked his stick and zoomed over on his back. Hanging head downward, he opened the throttle and was on the gray biplane's tail.

couldn't speak the language. He knew that all the tribes of Madagascar spoke the same language with different dialects and usages. But he couldn't speak any of them. An exclamation from Sandy tore his eyes from the ground below.

"Look, Bill!" the kid said, excitedly. "Look at that bomber. It's circling above something along the road."

Bill whipped a pair of binoculars out of a side pocket and glued them to his eyes. The bomber was circling above the Tananarivo-Ankazobe road a few miles away. And along the road toward the capital rose a thin line of dust, a lazy line of dust that Bill knew rose only above a column of lumbering trucks and rumbling caissons. In his mind he could hear the quick, staccato voice of a French sergeant counting the marching time: "*Un, deux; un, deux; un, deux; un, deux!*"

Only these men were not marching. They were being conveyed in the large gray trucks of the French army. He could make out the light-blue of their uniforms and see the sun glistening on their bayonets. He judged by the number of trucks and the uniforms of the men that they were a company of French infantry and two of Malagasy

tirailleurs, and a machine-gun detachment. Following them were a half dozen French 75s, and a couple of anti-aircraft guns mounted on trucks. A small, fast, armored tank led the column.

STURGIS BENTON, the American consul, Bill decided bitterly, had broken his word to him. He had gone to the French officials after all. But perhaps it was just as well. They certainly looked as though they meant business.

But what could they do with that handful of men against the thousands of armed natives and artillery in that fort on the plateau? He laughed sardonically. A lot of good the French were going to be to him.

"Bill!" Sandy shouted. "The big plane is bombing those trucks!"

Bill snapped the binoculars back to his eyes. A bomb had struck beside one of the trucks bearing an anti-aircraft gun. Gun, truck and men had been blown in every direction. The men on the other gun were slapping a shell into the breech. A roar and a white puff of smoke appeared not far away from the bomber.

The big plane nosed upward and cir-

pled toward the front of the motorized column. Two bombs crashed to earth a couple of hundred feet away from the trucks bearing infantry in sky-blue.

Bill cursed to himself and opened the throttle of the Scarlet Stormer. He wondered why the French didn't have some military planes with them to protect their trucks. They must have planes at Diego Suarez.

Then he forgot the French army and the trucks below him. He forgot everything but the huge bomber bristling with machine guns. He waited until he was only a few hundred feet above the bomber before he clamped his fingers down on his gun trips. White streams of tracers danced out to meet those coming from the machine gun atop the bomber. He shoved his stick forward a little to correct his aim. Bullets tore through the tail of the Stormer as he went over the big plane at a terrific speed. The forward gunner raked it again as he pulled out of his dive and chandelled back. Four machine guns poured lead at him as he sped back to the attack. Bullets seemed to come from everywhere. He zoomed upward to escape that deadly hail of lead.

The bomber circled back to renew its attack on the column below as Bill shoved the Stormer into a vertical dive. Air screamed and shrieked between his bracing struts as he opened his motor. Down a thousand feet, he eased up and came underneath the bomber. A belly gun poked its nose out of the fuselage and opened fire on him as he zoomed upward. The swivel guns along the sides added their *tat-tat-tat* to the stutter of the belly gun. He kicked the Stormer out of range again and climbed upward. To avoid being hit he had to maneuver at such a high rate of speed that his own shooting was inaccurate, while the gunners in the bomber were shooting with devastating accuracy.

He glanced out at the gull wings of

the Stormer and cursed bitterly. A terrible fury suddenly took possession of him. The blood drummed into his bronzed face and turned it a deep-red. First this crew of murderers had shot down one of his Snorters over the Mediterranean. Then they had kidnaped and perhaps killed his chief of staff, Shorty.

Red Gleason's Snorter had been perforated until it was useless. Sandy's Eaglet could barely get off the ground to be stowed away inside the transport. Now they were methodically drilling the Stormer full of holes.

How some of his men had escaped death was more than he could understand. It would cost him a small fortune to replace the lost Snorter and repair the other one and the Eaglet—to say nothing of the Scarlet Stormer.

Bill raised one huge fist and brought it down in the palm of his other hand with a resounding smack. Sandy gazed at him with eyes that were wide. He had never seen Bill Barnes in such a rage before. He had never seen his eyes gleam with such a wild, mad light.

"I'll knock their bomber from here into the Indian Ocean!" he roared into the telephone. "Then I'm going up and bomb their fort off the face of the earth. I'll get Shorty or I'll kill all of them!" His lips twisted into a snarl as he stuck the nose of the Stormer up until he was a thousand feet above the bomber. Leveling off on an even keel he glanced down over the side. The bomber was going back to its business of bombing.

"All right," he said. "You asked for it. Now you get it!"

His muscular hand pushed the control column forward until the nose of the Stormer pointed almost straight down. He yanked his throttle wide. He began firing long before he was within range, correcting his aim as he watched his tracers. A rail of lead came pouring back at him, but he kept straight on.

The machine gun in the top of the bomber became silent. The starboard swivel gun swung down, unmanned. His powerful bullets raked the length of the big ship as it yawed wildly. The forward gunner fell dead over his gun. The big ship tried gallantly to right itself. Then it rolled over lazily. The nose dropped and it began a dizzy descent to earth.

The Scarlet Stormer bounced upward a hundred feet when the big ship struck the ground and its two thousand pounds of bombs exploded. It tore a great hole in the earth far to the left of the column of trucks.

Bill and Sandy could see hundreds of faces turned upward. Their mouths were open and their arms waving in the air to acknowledge his victory.

But Bill didn't pay any attention to them. He drew his map shelf toward him and made an outline on a piece of paper as he held the Stormer steady. Underneath it he wrote:

Above map will give you an idea where passable road to fort on plateau joins Tananarivo-Maevatanana road. You will probably have to take heavy strafing as you approach fort. It is well armed and fortified. Will bomb fort from air. Would advise abandoning trucks halfway up and proceeding carefully. Native troops well armed and trained. Would lay down barrage. Will observe your fire and drop corrections.

Bill Barnes

He flew low over the head of the column of trucks and dropped the weighted note out in a miniature parachute. A French colonel leaped from an armored car and picked it up, waving his arm in acknowledgment.

Bill circled overhead for a matter of fifteen minutes while the column came to a halt. A half dozen French officers stood in the road waving their arms. At last one of them looked up and waved an arm at Bill. Bill flew low above

them. The officer pointed to himself and to the trucks and then pointed a hand toward the plateau to the northwest.

Bill flipped a hand into the air to show that he understood. He hoped the Frenchmen would have enough sense to send an advance guard up that road in front of their main force. He knew that they could be ambushed and wiped out if they were careless. But that was their business. He kicked the rudder of the Stormer and pulled back on the stick. Then he flipped over the radio-telephone switch and began to chant Cy Hawkins' code initials.

"Cy answering, Bill," came back over the phone. "Cy answering."

"Get up above that fort and see what you can do with your bombs," Bill ordered. "Keep away from those shells. I'll be there to protect you in a few minutes. The French have sent three companies of infantry, a machine-gun detachment and some 75s to take the place. They'll begin pounding it with their 75s before long."

"They'll have to do a lot of pounding and take a lot in return," Cy said. "That place is no set-up."

"I told 'em," Bill said, shortly. "Stay away from those anti-aircraft shells."

"O. K., Bill. Signing off," Cy said.

XIV—HEILNER'S STAND

BILL spiraled upward until he could see in every direction, as far as the eye could reach. He watched the French find the road that led to the plateau northwest of the main motor road.

When they were three quarters of the way in, a salvo of the guns in the fort above sprayed them with shrapnel and shells. The roar of the guns from below became deafening as the French unlimbered their 75s and sent them into action.

Men in the sky-blue uniform of

France and of Malagasy tirailleurs poured out of the trucks and formed in columns of fours, their long bayonets gleaming on their shoulders. The heavily armored truck kept on up the road in front of the marching infantry, its guns blazing a path ahead of it. Behind it came armored trucks with machine guns bristling from all sides.

Near a bend at the rim of the plateau, rifle fire and the *put-put* of machine guns tore the French advance guard to bits. Some thirty men lay where they had fallen, riddled by the sleet of lead from the ambushade ahead.

"They'll cut them all down like rats if they try to go in there before they've paved the way with their 75s," Bill said to Sandy.

The kid's eyes were as round as saucers as he watched the French infantry deploy to the sides of the road and move cautiously forward through the almost impassable jungle. "They ought to send a detachment around to attack from the other side," he said.

"They ought to. But they won't," Bill replied. He saw his own bomber circling high above the fort on the plateau. As it circled slowly it laid egg after egg—bombs—on the guns concentrated within the inclosure.

Shells burst all about it but only caused it to bounce in the air as though it had struck a series of air pockets. Then Bill saw something that made his lips come together in a thin, straight line. He saw two gray fighters whip into the air and begin to spiral upward. One of them stuck its nose toward the transport while the other took a course almost due east. Bill watched the second one with narrowed eyes. He didn't believe the pilot of the plane flying toward him could see him because the sun was on his back. He continued to circle until the gray ship was over the rim of the plateau. Then he knew what it was going to do.

As the gray plane swooped low to strafe the advancing French infantry Bill pushed his stick forward and dove. The pilot of that gray plane was firing burst after burst of lead into the defenseless infantry when Bill clamped down on his triggers. The pilot of the enemy plane never knew what hit him. One second he was bent forward over his guns spraying the earth with lead. The next he was crumpled up on the deck of his cockpit and the gray plane was plunging at a fearful speed toward the jungle below.

Bill waved a hand over the heads of the cheering Frenchmen below him and stuck the nose of the Stormer up again. He saw the other gray plane dart at his transport like a terrier snapping at the heels of a mastiff. It dove, spun and zoomed to avoid the guns of the transport and to get in a telling burst of fire. The transport continued to circle, dropping its bombs at intervals. The bombs were taking a deadly toll within the fort. Men lay all about inside the inclosure. Buildings were wrecked, guns demolished. Death was everywhere.

Shells from the French 75s were roaring in at regular intervals now. Little trucks carried shells from the round building, which was the magazine, to the black gunners.

Bill's heart was sick at the thought that Shorty might be some place among those horribly demolished buildings. His stomach turned over and he tried to throw the thought from his mind as he took the thundering Stormer into battle with the last of the little gray fighters. The pilot of this plane would be the one Red had fought with the day before. The scar-faced War ace who had fought Red to a standstill.

AS Bill took one last look down and back to see how the French infantry were faring the gray biplane came hurtling down at him with its guns

streaming. He saw it barely in time to throw the Stormer out of range. The plummeting biplane screamed past him. Bill's gaze followed it and saw the hideously scarred face of the pilot. He watched the man bring it out of its dive and zoom upward. He could tell by the steadiness and precision of the maneuver that the hand on the stick of the biplane was a hand that had guided a thousand planes in battle. Bill's hand tightened on his own stick. His eyes gleamed as he swung the Stormer around to head back.

The biplane came sweeping around in a tight Immelmann. Bill eased up on his throttle and pulled back on the stick. He fingered his firing trips while his eyes squinted along the gun sights. He heard Sandy's voice in his ears:

"Get him, Bill!" the kid said.

The gray fighter charged furiously down correcting his aim with his tracers as he came. Bill held his fire and opened his throttle wide. His powerful motors bellowed as the Stormer leaped upward. The bullets tearing at him from the biplane churned past underneath them.

As the two ships passed one another Bill kicked his rudder and threw the stick over. The Scarlet Stormer whipped around like a prancing horse whirling on its hind legs. Then he dove. The pilot of the gray fighter threw his biplane into a frantic side slip. But Bill's speed was terrific. Before the enemy plane could get from under his sights Bill's fingers clamped down. The two guns roared. A deadly stream of lead swept across the biplane's engine, and then it was past.

When Bill swung back to the attack his eyes opened wide in amazement. Smoke was sweeping back from the biplane's engine housing. His first burst of fire had drilled through the engine block. As the gray fighter pulled steeply around and headed back

Bill pulled his stick back. He pointed the nose of the Scarlet Stormer to meet it. Black smoke and fire were billowing back from the engine of the onrushing plane as it dove with its guns streaming wildly. Its speed was terrific.

Bill did not realize until the plane was almost on him what the pilot was trying to do. Then he threw the Stormer desperately to one side. A sheet of paper could not have been inserted between the wing tips of the two ships as they passed at terrific speed. Bill leveled his ship off. For a moment he became dizzy. The madman in the other plane had tried to ram him head-on! It was a last desperate effort.

The little gray fighter never came out of that last, wild plunge. It kept straight on toward the earth with the scar-faced pilot either dead or helpless at the controls. Straight into the heart of the jungle it plunged to shoot flames fifty feet into the air as the ball of fire crashed.

Bill wiped the perspiration from his forehead and glanced back at Sandy. The kid was grinning! He didn't realize how close he had come to death.

"That was swell going, Bill!" he said. "There's something funny down there below, in the fort."

Bill looked downward to see that the anti-aircraft guns had been silenced. Also the howitzers. The place seemed to have gone mad. Black troops were fighting to get *out* of the fort!

Then he saw that men were running in every direction, away from the round, brick building that was the arsenal. On top of the arsenal were two white men and a woman!

The men had machine guns and they were spraying the inside of the fort with their fire. The crews of the machine guns around the walls of the fort had deserted their posts.

The gates of the fort crashed in as the heavy French tank drove through it.

The French infantry poured through the gate after it. There was no opposition to the advance. The blacks were streaming out of the other side of the fort, throwing their guns away as they ran.

A French bugle's clarion notes shrilled above the occasional crackle of rifle fire. "*En avant!*" screamed a hundred frenzied voices. The French had taken the fort to find it undefended.

Sweeping low, Bill skimmed the top of the arsenal, being careful to have enough speed to avoid the fire of the machine guns there if they were turned on him. But they were not turned on him. Instead, one of the men on the roof began to dance and wave his arms at him. He whipped back and peered more closely.

It was Shorty! Shorty and a tall, young man with blond hair and fair skin. He, Bill knew, would be young Wyndam. But who was the girl?

THAT EVENING the plateau that had so recently been swarming with the army of General Heilner was dotted with camp fires. Malagasy tirailleurs and French soldiers sat about them singing folk songs far into the night.

About one of the fires sat Bill and his men, Dick Wyndam, Cistra Boettner and a French colonel.

"You see, colonel," Wyndam was saying to the Frenchman, "Miss Boettner is going to be my wife as soon as we can post the bans in the capital. She was forced into this thing unwillingly and we just got her out in time. If she hadn't freed Mr. Hassfurther and myself and got us those machine guns to-day your whole force might have been wiped out before you got in here. The machine guns inside the walls did the trick."

"Trick? Trick?" the French colonel said.

"Sure, trick," Sandy put in. "Trick—like a dog does!"

"Shut up!" Bill shouted.

"Enough!" the Frenchman said.

"Miss Boettner will not be bothered and the others are dead. But you, my friend," he said, turning to Bill, "you and your men will be recommended for decorations by my government. You have, perhaps, saved our island."

Bill's face flushed and he was pleased. But he shook his head.

"No decorations," he said, emphatically, "and no publicity. I want to keep out of the papers. I get too much of that stuff."

"Listen!" Sandy interrupted. "Speak for yourself, Bill. If the guy wants to give me a decoration—I'm taking it!"

PROBAK

JUNIOR

4 BLADES for 10¢

ALSO 10 FOR 25¢
25 FOR 59¢



MADE IN U.S.A.
T.M. REG. U.S. PAT. OFF.
OTHER PATENTS PENDING

HERE'S THE TOP in Shaving Value

● Unusual shaving results plus a record-breaking low price have won nation-wide popularity for Probak Jr., the sensational new double-edge razor blade. Made for quick, easy work on rough beards, this blade is ground, honed and stropped automatically. Its amazingly keen edges glide through stubborn bristles with surprising ease. Try Probak Jr. and see.



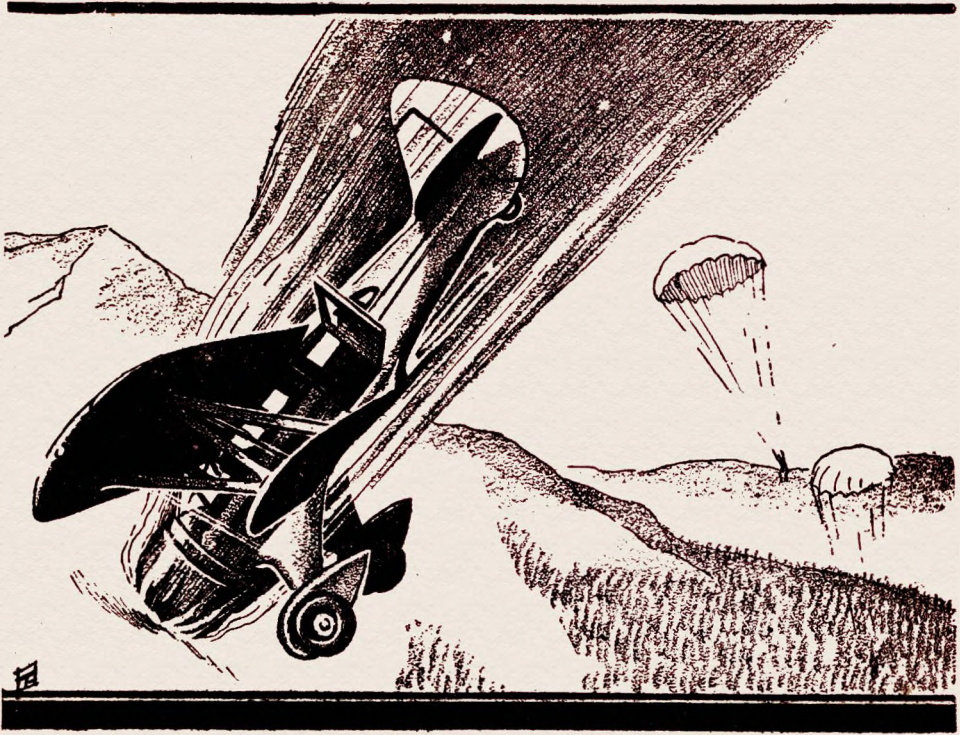

He nosed the blazing plane downward on a long glide, choking as he clung to the controls. Far behind, two billowing parachutes—

AIR ALIBI

by Frank Piazza

*A story of airway robbery
that will thrill you all the way*

SKIP" DAVIS moved restlessly in his wicker pilot's chair. Dim lights from the instrument board were dancing pin points in his narrowed eyes. Unobtrusively he glanced at Sime Nunn, his co-pilot, dozing in the dual-control seat beside him.

An uncanny feeling that Sime's little, sly eyes had been furtively watching him swept over Skip. Soundlessly he

whistled, staring into the inky darkness that shrouded the big mail biplane as it droned serenely on through the night.

In his racket, Skip reminded himself grimly, one never knew what kind of hell to expect next.

As usual, the thought cheered him and he almost grinned. Danger, the kind that promised unexpected adventure, hazardous peril, was as meat and drink

to Skip. The heat of conflict, of possible disaster, never failed to warm him.

This hunger for hazard had skyrocketed him through an army aviation course. That he had eventually landed as an inspector in the aeronautics' division of the department of commerce, with a roving assignment, was only natural.

For Skip had an instinct for trouble and a flair little short of genius for surmounting the difficulties which beset his eager steps. And his job provided him with the danger he craved.

Aviation, like other lucrative enterprises, had attracted the hungry attention of illegal and predatory gentry. Skip, almost single-handed, had carried on the warfare against them, with a degree of success that kept certain gentlemen in Washington in a sweat between back-slapping exultation and heart-sickening anxiety.

Now, his fearless blue eyes roving over the myriad dials that glowed on his bronzed young face from the instrument board, Skip toiled the huge trimotored ship blindly through the night.

He was not Inspector Skip Davis now; he was Transport Pilot Davis of the air mail, to all intents and purposes.

Wind whistled through the rigging. The three radial Hornet motors throbbed rhythmically. They were two hours out of San Francisco, bound for Reno, with two thousand pounds of air mail in the big compartment behind the dual pilots' seats.

Skip grinned hopefully at the thought of the air-mail cargo. It accounted for his presence in the night-flying mail ship as pilot.

"Four sacks of registered air mail for the Chicago Bank and Trust Co.," Skip muttered to himself.

"If that's what I think it is, we'll have excitement some time between here and Reno, or I miss my guess. Four sacks of registered mail for that bank means plenty of you-know-what. No doubt of

that. And the gang that's been working this route seems to have inside information on cargoes like that, according to Kent Lambert. He's the operations' manager; he ought to know. I'll bet a month's pay hell will bust loose and barge all over these Sierra Nevadas yet to-night!"

He shrugged carelessly, feigning elaborate absorption in the functioning of his motors.

"Listen! What's that?"

Nunn's voice stabbed through the roar of the radials, high-pitched with excitement. The co-pilot sat bolt upright, wide-awake now, his body tensed forward in a listening attitude. His cryptic eyes were feverishly bright.

"What is it?" Skip demanded, blue eyes sparkling.

He strained sensitive ears futilely. He had heard nothing. He doubted very much if his co-pilot had either. The throb of the three motors and the scream of the wind through struts and guys would drown out any ordinary sound. Even the drone of another airplane. But too evidently there was something out in the impenetrable darkness. The flesh at the back of his neck was creeping. He knew the feeling of old. It reeked of danger.

Skip grinned happily. Nunn mistook the smile for disbelief.

"Don't you hear it?" he shot out, his high-pitched voice cracking. Fiercely he gripped Skip's arm.

Skip continued his assumed indifference. It might cause Nunn to reveal something.

"Cut it," he chaffed. "You've got static. I don't hear a thing. This night flying over the hump's got your nerve. It's affected your hearing. I'm new on this run and not yet used to your local Sierra sounds."

Face expressionless, he stared ahead owlshly. But his brain was seething. What was out there in the jet blackness that Nunn had sensed? Or had Nunn expected it?

Whatever it was, it meant danger to Skip Davis and to the mail cargo entrusted to his custody. He felt as he had the first time he had ever bailed out of a crate to join the Caterpillar Club.

Abruptly Nunn screamed.

Somewhere near by a dull hammering pounded savagely.

Skip's heart leaped as he recognized the staccato stutter of a submachine gun.

"It's the air pirates!" Nunn's teeth were chattering. "They're shooting at us! They'll kill us! We'd better jump. It's our only chance in the dark. Come on. Let's bail out before they hit the gas tanks and cremate us. To hell with the air mail! Come on!"

Wildly he leaped to his feet and tugged frenziedly at Skip to follow him.

Skip shook him off and slammed back the glass window panel at his side. The sound of the stuttering submachine gun was loud and distinct now. It was close. Too close, he decided grimly.

The attacking plane was on his left, behind and below him. He could see the livid flashes of flame from the sputtering gun below his left wing.

Yet no bullets struck the cabin of the air-mail ship and the motors still functioned perfectly. Skip's eyes sparkled bluishly and he grinned knowingly.

"Hold on, Nunn," he yelled. "They're right below us. I'm going to drop this crate down on them. It'll crash their crate and this trimotor is too big to be damaged. At this altitude they'll have plenty of time to jump out and take to their parachutes. Here goes!"

Eagerly his strong hands tightened on the control wheel.

Then dynamite seemed to detonate under his skull and he forgot everything he intended to do.

IT WAS morning when he regained consciousness. He groaned feebly. Weakly he shook his throbbing head to banish the fog in which he seemed to be lost. The motion awoke waves of

nausea that swept over him like tidal seas. Through bloodshot, wavering eyes he glimpsed a reeling, unsteady world. A quivering ball of fire whirled before his hazy eyes.

Then the nausea abated and he felt better. Slowly, fearfully, he again opened his eyes.

"All the symptoms of a hang-over!" he muttered ruefully.

He forced a faint, white-faced grin at his own joke, as he saw that the ball of fire was the morning sun, now well above a pine-clad, unfamiliar mountain ridge.

He tried to sit up, and failed. Sharp pains shot up through his arms and legs. Perplexed, he stared at himself. Tightly bound, he was lying on the dew-wet grass of a long, narrow, mountain-girt meadow.

Thoroughly puzzled, he gazed around. His feverish eyes steadied on the mail plane, silvery and cold in the slanting, morning sunlight. The giant ship loomed almost directly over him. One wing, in fact, partly shielded him. Beyond, toward the tail, rested a sleek, black, cabin monoplane.

Remembrance flooded over Skip like an icy shower.

"So my suspicions of Nunn were right," he muttered grimly. "He's in league with the air bandits. That explains why he knew when to expect those night buzzards to show up. He knew to the minute when they were to open fire on the mail plane. And that explains why he tried to stampede me into bailing out. He wanted me to jump out and desert the mail ship.

"He'd have let me jump alone, too, the double-crosser. That's what he wanted me to do. That explains why we weren't hit once by that machine gun. That was just a stall, a ruse, a plant to get me excited enough to take to my parachute.

"They wanted me out of the way. If I'd jumped like they figured on, like

some of the other mail pilots did, they would have looted the air-mail ship at their leisure. With Nunn alone in control of this big crate, if I'd jumped, they would have been in full possession of the air-mail ship and its cargo.

"But I didn't scare worth a hang, damn it! Instead I pulled the prize bonehead stunt of my short but thrilling existence and broadcast to Nunn my neat plan for wrecking his accomplice's plane!"

He shook his head sadly.

"What a fine grease monkey I turned out to be," he groaned ruefully. "I wonder what he hit me with? My head feels like it got in the way of a four-bladed prop and every blade made contact. Whew! But I've got to get out of this mess or Kent Lambert's suspicions of me will be justified. He sure questioned me enough before he gave me the job of flying this night run. But judging from the results I don't blame him!"

He strained suddenly against the cords that bound his hands and feet. Beads of sweat bloomed on his brow; the thongs cut into his wrists; his face purpled with his effort to sunder the bonds. In vain; they held like steel traps. He stopped, exhausted, teeth clenched bitterly.

Not a chance to break loose, he decided.

"I wonder if they frisked me?" he muttered. "They took my parachute away. Let's see."

With his bound wrists together he probed his pockets. His automatic was gone from his side pocket; keys and a knife were missing from his hip pocket. Then he felt inside his leather flying coat, near the waistline, where there was a hidden pocket. His heart sang with hope as his probing fingers discovered the outlines of a tiny pair of pliers.

"Right where I always carry that emergency repair tool!" he gloated ex-

ultantly, his fingers worrying at the inside flap of the hidden pocket.

Abruptly he froze, then straightened his arms and watched the slowly opening cabin door of the air-mail ship.

Nunn stood framed in the doorway, sardonically grinning down at the helpless pilot. Still rubbing the sleep from his sly, foxlike eyes, Nunn dropped to the ground and sauntered toward Skip.

"Well," he purred, "how do you feel after stopping a gun butt? Did you sleep well?"

"Where," Skip rasped, hiding the black rage in his heart, "are we? What happened?"

Nunn's wolfish lips curled in a sneer.

"I thought you told Lambert you knew every acre in California when you got the job as chief pilot on this night-mail flight?" he taunted venomously. "You lied, didn't you? I can't figure why Lambert put you on. You've got a drag with the big shot of the company, I guess. Well, it won't do you much good now. You're through flying for a while. We're near Tuolumne Meadows, not far from the Yosemite Valley. I landed the ship here last night after rocking you to sleep with a gun butt. In half an hour we're hopping off for Tiajuana. And you're taking the ride with us. If it's any news to you, there's half a million dollars in currency in those four sacks of registered air mail!"

Skip's brain reeled. "Half a million dollars!"

THE WORDS escaped him involuntarily. In spite of himself he was jolted. He had known that the ship carried currency; Lambert had hinted as much when signing him on as pilot, and Skip had prepared for that eventuality. But he hadn't expected anything like this. Half a million dollars! What a haul for the air bandits! Skip's mind reviewed the disaster that had overwhelmed him.

How had the air bandits learned of this huge shipment of currency? Nunn?

Skip's lips tightened, but he shook his head. Nunn was in league with the bandits, all right, but he wasn't the man higher up. There were others in this gang. An idea tossed at the back of his brain. Thoughtfully he stared at Nunn, who stood smiling maliciously down upon him.

"What are you going to do with me?" he asked at last, watchfully scanning his co-pilot's beady eyes.

"You know too much for your own good to let you go here," Nunn replied importantly. "We're heading for Mexico with the coin and you're coming along so you won't spread any alarm until after we're in a safe country where there's no extradition."

"Like hell he is!"

A harsh voice knifed into the conversation.

Skip cursed the thongs that bound him as he wrenched around violently to glimpse the speaker.

His blood froze at the sight of the two desperadoes who had approached so silently. The mark of the killer was written in both faces. Both bandits kept their hands ominously hidden in the pockets of leather flying coats.

The one who had spoken was hawk-faced, with a nose like a saber, three livid knife gashes under a chill-gray eye twisting his face into a horrible leer, and a thin, blue, cruel mouth.

His companion had the gross, heavy, emotionless face of a butcher. Fishlike blue eyes looked out from a masklike face.

"Scarface" spoke again, spitting out the words biting.

"When did you muscle in as the big shot, Nunn?" he snarled. "You're not making any plans for any one in this outfit, get me? This mug's not going to Tijuana with us. He's on the spot. You should have bumped him off last night. But you turned chicken and failed. It's up to you right now. Make it snappy; we've got to be on the lam

and he knows too much. Come on, drill him!"

Nunn's face went white at the cold-blooded order.

All the arrogant assurance of a moment before vanished. His lips quivered; he shook feverishly, recoiling from Scarface as from a viper.

"Don't!" He wrenched out the word, held shaking hands in front of him. "I can't murder. Murder! I can't. I won't. I won't, I tell you!"

"Oh, yeah?"

For the first time the fish-eyed killer spoke, growling out the words.

Skip Davis read the murderous intent in the killer's snakelike movement of the hand. A strangled shout of warning—too late—burst from his suddenly blanched lips.

Nunn screamed once in reply, to the accompaniment of a single shot.

Then he clawed horribly at his stomach and sprawled limply in the grass, face down. His legs twitched spasmodically. In a moment he lay still.

"Fisheyes" lowered his still-smoking gun. His queer eyes were flat, lusterless, devoid of all expression.

"What the hell did you do that for?" Scarface snarled, whirling on his accomplice.

"Why not?" Fisheyes growled heavily. He nudged the still form at his feet. "He was sounding off too much. And I've got an idea for an alibi."

"What do you mean?" demanded Scarface, eyes still glittering dangerously.

"Listen," said Fisheyes, his basilisk gaze intent on Skip. "What's going to happen when they find this air-mail plane here, the money sacks gone, and the co-pilot dead?"

"Spring it."

"Suppose the pilot is missing?" Fish-eyes continued calculatingly. "The co-pilot is dead, the money gone, and the pilot missing. Who do they suspect?"

Us? Hell, no! The missing pilot, of course!"

Scarface's ugly visage broke into a mirthless, satanic grin as the idea filtered into his warped brain.

"You mean——" He stared at Skip's wide-eyed, bleak, haggard face.

"Yeah," nodded Fisheyes carelessly. "We'll take this mug along with us—as far as Death Valley. At twenty thousand feet we'll push him out, without a parachute. He'll dig his own grave from that altitude. They'll never find a trace of him. And that'll be our air-tight alibi!"

"Mail ship looted, co-pilot murdered, pilot missing with the cash. And he'll never be found, either. Foolproof, eh? We won't even have to go to Mexico. They'll have this rat indicted for murder and robbery in twenty-four hours. But they'll never find him in the desert; not after he drops four miles!"

"Yeah! Yeah!" Scarface gloated, rubbing his hands together. "There'll be no squawks back on this job, either. We can split two ways only, eh?"

Understandingly they nodded at each other.

IN Skip's brain, the idea that had been teasing him took shape. His eyes were alert and bright, not at all like those of a condemned man, when the air bandits slung him between them and dumped him unceremoniously atop the four sacks of money in the cabin of the black monoplane.

Scarface slid into the pilot's seat, still buckling on his parachute pack, while the other bandit cranked the inertia starter. The whining grind of the starter filled the forest air, then the radial barked, sputtered, and roared into life. Fisheyes climbed into the cabin beside the pilot, stowed his parachute comfortably, and slammed the door shut.

On his lumpy bed of currency Skip felt the monoplane bump along as it

gained speed for the take-off. Scarface turned and leered at him.

"You're going for a ride, mug!" he shouted above the crescendo whine of the laboring engine.

Skip said nothing. Fisheyes paid no heed to him.

Then the bumpiness ceased and Skip knew they were in the air, bound for Death Valley. He could not see out of the cabin, but he could feel the ship climbing steadily, soaring for altitude.

"He's climbing plenty, all right," Skip muttered ruefully.

Mentally he visualized his finish. A brief hesitation of the monoplane over Death Valley, twenty thousand feet below. Fisheyes would open the cabin door and Skip would be shoved out, bound, helpless, doomed. Almost he could feel the long, sickening, breath-taking plunge to an untraceable death in the lonely desert below. He would never be found. At twenty thousand feet the plane would be almost invisible from the ground. And he would hit with such force as to bury himself completely.

Back in San Francisco he would leave a black record, never to be cleared, of murder and robbery. A record of treachery, of unfaithfulness. A record that would stand against him forever. While Washington would wonder if its roving aeronautics' inspector had been tempted by the opportunity for sudden wealth and had betrayed the confidence reposed in Skip.

Skip Davis grinned at the forbidding picture. Fortunately both the air marauders were intent on the continued climb of the monoplane and did not see Skip's face.

Eyes watchfully on the two bandits, Skip carefully doubled up with the effort of fishing the tiny pair of pliers from their secret hiding place.

Silently he worked the little instrument out and at the expense of lacerated wrists he forced the cutting blades

around the cords that bound his wrists. Then, straining the muscles of his wiry fingers mightily, he succeeded in clamping the plier handles tightly shut between his palms. The cords snapped apart.

He was free!

A grin tinged his lips as he chafed his bruised wrists. Both Scarface and his companion were unaware of his escape. They were intent on the flight of the plane, still soaring for altitude.

Cautiously Skip searched among the four mail bags holding the fortune in currency. Unerringly, as though by prearrangement, he picked out one sack and broke the seal. Apparently unaware that he was rifling a United States' mail bag he slid in his right arm to the elbow.

When it reappeared his hand was clutching a squat automatic. And he was grinning queerly at something he saw in the bag.

Deftly now, Skip cut the cords that bound his ankles. His eyes hard and frosty, he straightened to his knees, gun in hand, confident, ready for the show-down.

"Stick 'em up!" he barked. "You with the slashed face, keep one hand on the stick and watch your flying. I'm shooting for keeps at the first sign of a double-cross!"

With one accord Scarface and his accomplice whirled in their seats and stared unbelievably at the menacing figure behind them.

Then all hell broke loose in a dozen places.

SKIP FIRED wildly and missed as the cabin floor bucked upward. He was hurled forward by Scarface's sudden nose dive. Frantically clawing for a handhold Skip crashed head-on into the bulky figure of Fisheyes, half risen in his seat. Hampered by his 'chute pack, Fisheyes was tugging madly at his gun pocket, murder in his flat eyes. Scar-

face pulled the throttle wide open in a screaming power dive.

The terrific impact of his plunge into Fisheyes sent Skip's gun slithering away in the steeply tilted interior of the plummeting monoplane. Fisheyes' gun jerked free and Skip lunged for his gun hand, fighting desperately to turn the flame-belching weapon away. Hot flame stabbed at his side and he felt the warm trickle of blood plastering his shirt to his body.

Scarface screamed vile curses as he sought to break the battling pair apart by wild gyrations of the monoplane. One instant of freedom and Fisheyes could finish Skip.

The monoplane hurtled into a loop. Immelmann turn followed, barrel rolls, chandelles, stalls, slips, falling leafs, in a wild jamboree of aerobatics.

Locked in a deadly embrace, Skip clung tightly to his opponent's gun hand, taking a fearful battering from the other fist. The erratic, insane maneuvers of the monoplane smashed him from pillar to post, but he clung tenaciously to Fisheyes' gun hand.

So wrapped up in their murderous feud were the two that at first they did not hear the shrill screams of the pilot.

"Fire! Fire! Break, you fools!"

Skip and Fisheyes catapulted apart. Gasping, spitting blood, Skip grasped the situation at a glance.

The exterior of the plane was sheathed in flames!

Scarface's wild aerobatics had taxed the engine. Flame was licking from the radial motor in long tongues that curled hungrily past the windows of the cabin.

Momentarily paralyzed by this new disaster Skip forgot his adversary.

Fisheyes seized his opportunity. Murderously he struck with his clubbed gun. The blow caught Skip on the side of the neck and he dropped like a poled steer.

"Quick!" snarled Scarface. "Throw those mail sacks out. We've got to

jump for it. The engine's afire and the crate will be in another minute. No need to shoot this rat. He'll roast in this coffin. He hasn't got a parachute!"

With a sardonic leer at the unconscious Skip they plunged out of the plane after the money bags.

Pilotless, relieved of the weight of Scarface and his companion, and the four sacks of currency, the monoplane went into a side slip. The motion rolled the half-conscious Skip toward the open cabin door through which the two bandits had plunged in taking to their parachutes.

Inches from Skip's battered face tongues of flame licked searingly. The flames, now that the plane was gliding slowly, could gain headway. In a moment the fuselage would be afire.

The heat seared Skip's face and stung him into life.

He groaned and rolled over on the slanting cabin floor. Desperately he flogged his numbed brain and opened his eyes. The flames scorched his face, brought him to a full realization of his predicament. Moaning with pain, he threw out his arm and slammed the cabin door shut. With superhuman effort, flogging his cringing body, he dragged himself to the pilot's seat.

It was his instinctive air sense that guided him now. He was too far gone physically and mentally to plan or to act coherently. But his instinct told him a power dive, with the gas throttle wide open, might whip out the flames. That was his only chance. If he failed he wouldn't have to pull the plane out of its dive. He would be through.

A glance at the altimeter showed him he still had over five thousand feet of altitude. Room enough for a desperate chance. He shoved the stick forward. Responding to his movement the monoplane nosed earthward. The radial motor roared louder as he gave it the gun. The hurtling plane quivered and strained, shaking as though it would

wrench itself apart. The air-speed gauge climbed dizzily to two hundred miles. The wind howled fiendishly through the strained and creaking struts.

Suddenly Skip realized the flames were no longer licking past the cabin windows. The terrific dive had whipped them out!

HE EASED off the gas feed and gently pulled the stick back toward him, leveling off. Quivering like a race horse at the end of a fast run, the monoplane came gamely out of its nose dive. The altimeter showed less than a thousand feet.

Skip opened the glass panel at his side and inhaled great gusts of fresh air. Every breath cleared his brain. For the moment he was safe. But the air bandits had escaped him.

He stuck his head out of the window, looked down, then up. Floating gently, swinging in lazy arcs, he spotted the two gunmen in their parachute harnesses. They were above him. Skip's reckless, strut-straining, wire-stretching dive had carried him down faster than the 'chutes.

The sight spurred him even as an idea dawned full-fledged in his active brain.

He banked sharply and nosed swiftly for the nearest parachute.

"This'll throw a scare into 'em but won't kill 'em." He grinned. "They've still got to talk plenty turkey to me. I think I know who engineered their jobs now."

Judging his distance nicely he swooped into the 'chute, catching the cords on his left wing tip a yard above Scarface's terror-stricken face. The 'chute whipped back over the wing and Scarface hung suspended in his harness, dangling from the front of the wing. The force of the wind, Skip knew, would keep the parachute in position and prevent Scarface from dropping.

Compensating with his controls for the added weight on his left wing Skip

again banked and flew into Fisheyes' parachute. He caught the horrified killer less than five hundred feet from the ground. Like gallows birds they hung suspended in their parachute harnesses, one on each wing tip.

The monoplane sagged under the weight of the two wind-whipped parachutes and their burdens, but did not falter. Grinning widely at the terror-stricken faces of his captives Skip retrieved his gun.

He laughed, when, in landing, both bandits crawled up the parachute cords and hung to the wing edge so that they wouldn't drag and be battered on the ground. The high wing of the monoplane aided them.

Gun in hand, eyes cold and grim, Skip herded them out of their harnesses.

"All right, you two thugs!" Skip rasped frostily. "Who tipped you off to the coin in the mail plane? Talk fast!"

"To hell with you!" snarled Scarface, his face distorted with hate. "You'll get nothing from me."

Fisheyes said nothing.

Skip Davis laughed. "Code of the underworld, eh? Keep your mouth shut. Say nothing. What a fine pair

of suckers you two turned out to be! Double-crossed by your own tip-off man! And now you're covering up to protect him! Just a brace of cat's-paws for a clever monkey."

"What do you mean?" demanded Scarface hoarsely, his eyes glittering.

"I mean that those four sacks of currency you threw out when the plane caught fire didn't contain money. There was nothing except piles of blank paper in the bags. The man who tipped you off to this shipment of money double-crossed you. He took the coin and substituted blank-paper packages! And played you for suckers all the way through!"

"Kent Lambert!" began Scarface, his voice cracking savagely. "I'll kill the fool——"

"Easy!" warned Skip, waving his gun threateningly. "Kent Lambert is right. I knew he was the tip-off man when I found that blank paper. Because the sacks contained currency when I hid my gun in the bottom. And only Kent Lambert knew about the shipment at headquarters. Your testimony'll cinch him for life at McNeil's Island. Come on, suckers!"

In case you've been wondering

THE RAINBOW GANG

by George L. Eaton

Will appear in the August Bill Barnes



The

A
*Bang-up
Short Story
of the
Air Trails*

by
Roger
M.
Clancy

*Then he was off,
twisting and turn-
ing in dizzy loops
through the air—
and his finger was
not in the para-
chute ring!*

Airport in the Valley

A SMALL PLANE rose from Snowden Field in a long ascent, climbed to about five hundred feet, banked slightly, and headed south, still climbing. From each of its two open cockpits a man looked over the side. The goggled and helmeted figure in the rear looked ahead for the most part—to the horizon and the nose of the ship, to the set of his wings, to the terrain ahead, and occasionally to the instrument panel in front of him. The other kept looking down at the flying field they had just left.

It was a beautiful flying day. There was little or no wind. Few clouds were in the deep blue of the sky and the sun shone brightly and warmly. Visibility was nearly perfect.

The field was on their left. On their right was a mountain; at their back, the little mountain city of Snowden, a city that is still rubbing its eyes and blinking in amazement at the phenomenal growth of its airport in importance and prestige and in the volume of its commercial activity.

From a vacant cow pasture, used first by itinerant barnstorming fliers and then by intrepid local youths aspiring to emulate them, the port has grown by leaps and bounds to become the center of a bustling air commerce. More than a score of widely known firms, with businesses a part of the aviation industry, have offices or agencies established there.

If the prime reason for this phenomenal growth is inquired of them, members of these firms are quick to refer the inquirer to the geography of the United States and then call attention to all the "meridian chasers"—the cross-country record seekers, sportsmen, adventurers, air-mail pilots, pas-

senger-line operators, and others—whose ships put in there.

The flying field itself lies in a valley, now a "valley of lost hope" for one Freddie Harper, the man in that front cockpit. "Fearless Freddie" he was to most people. He had been thus playfully but admiringly dubbed because, from the very day of his arrival at Snowden more than two years before this September Sunday, no one in all those two years or more had ever known him to be afraid of anything, least of all death, while going about the business of performing any of his spectacular stunts in the air.

But Freddie Harper, parachute expert, had become a craven. Fearless Freddie was afraid. It was not death that he feared but—life! And he was secretly taking a way out—a simple, easy way that would scarcely be likely to be called suicide. It would be certain to be called an accident, the sort of accident, he knew, that holiday airport crowds secretly, consciously or unconsciously, hope to be able to witness. It would be *the* accident, the one that can happen only once in a professional parachutist's career. His 'chute was going to fail—utterly. Thrill-thirsty visitors to the field were going to have their craving fully satisfied for once.

He knew it had been done before—by a despondent, friendless, homesick German exhibitionist, a beaten stranger in a strange land. But he had been crude and they had found him out. They had found his shroud lines tied in a knot and shame had attended his going out.

Looking down, Harper saw that they were there in unusually large numbers, these sight-seers, doubtless on account of the perfect weather. According to

his custom, he had just waved to them as the airplane took off over their heads, but this time he had waved a clenched fist and backed it up with a sardonic grimace. He was not feeling the least bit friendly or cordial toward his public, as he had so often jokingly referred to them.

AS THEY FLEW on and upward, he felt irresistibly drawn to the other side of the cockpit and found himself unconsciously looking for a familiar little white farmhouse on the mountain-side, the home of a dark-haired, brown-eyed girl named Gloria Emory, who taught school in Beaufort, on the other side of the mountain, and took flying lessons at Snowden Field.

He found it readily enough on such a day as that was—the kind of day on which, even from a good height, objects on the ground are seen through the intensifying heat haze clearly, as if through a giant reading glass; just such a day as he had patiently waited for to make his first parachute jump a long, long time ago, before he had become service man for a nationally known parachute manufacturer and himself had become nationally known.

That had been a big day for him—a momentous day—on which he had first received a “big hand” and then been acclaimed and fêted far into the night by most of the air-minded folk in the little backwoods town outside of which it all had started—the day that marked the beginning of his successful career.

Almost every day since then had been momentous and vibrantly lived; each marked by more daring and spectacular stunts, with bigger “hands” and louder public acclaim, with write-ups and interviews, with news-reel movie shots and posed publicity photographs.

Although his personality had remained that of the unspoiled, level-headed, rugged son of the soil, all this had come to be as food and drink and

life itself to him. Now he was putting it aside as meaningless and nonessential.

As they passed closer to the house, he wondered whether those little light-colored patches near it were Mr. Emory's chickens or Mrs. Emory's wash spread out to dry and if that dark blur was the pet Airedale sprawled at the top of the porch steps. Those were steps that he knew well. He had often buoyantly bounded up them; had often contentedly sat on them evenings—and afternoons, too—when Gloria and he had watched the ever-unfolding pageant of arriving, departing, and maneuvering airplanes above the field, while they chatted in sweetheart fashion.

Like many other families living on the hills that bounded the flying field, Gloria and her folks were fortunate in that they were able to look down into the valley and see their fill of aviation without leaving their front yard. It was true that they could not actually see the field itself with all the take-offs, landings, and other ground operations. Part of the mountain hid that much of the view from them, but they were able to see all that went on above a height of about four hundred feet, though, of course, that had not been enough for Gloria.

For an instant the sight of those porch steps conjured up an old image that Harper fondly used to see of his own front porch of the future with Gloria and himself sitting on it happily married. His dreams of settling down had been the logical ones for him. They had been the dreams of a homeless orphan, a vagabond of the air, a wanderer with nomad flying circuses and barnstorming expeditions, a rolling stone.

But all that happy envisioning had been prior to a day two months gone by when they had quarreled bitterly and separated. It had been over the long-debated question of her quitting flying

and his quitting jumping. The mental anguish professedly felt by each as a sweetheart when the other was in the air, had instigated the debates. The innate stubbornness of each had precipitated the quarrel, for both were mountain grown.

She had obstinately refused to give up solo flying unless he gave up jumping, which he obstinately refused to do on the grounds that it was a not-to-be-slighted means of earning a better livelihood and a most important part of his profession, which was the handling, repacking, repairing, testing, demonstrating, and selling of these life preservers of the air.

The rift had widened with the advent of the ardent social attentions of Jack Blayle, Gloria's instructor, and their seeming agreeableness to her. But there had been something more added to all this that caused him to draw into a shell and shun the world and his contemporaries, even his closest friends.

He turned his head away to efface the image with a stern finality. Then he felt Walsh, the pilot, tapping him on the shoulder. He looked behind. His bosom pal was grinning broadly and pointing down at the little farmhouse. Mocking him—even up in the air!

That was it—the mockery most of all—that was driving him to this act, and the merciless gibing, and the endless, grinning, insincere expressions of sympathy, all coupled with the soul-killing sense of utter defeat that weighed him down after seeing his well-laid plans for a long-dreamed-of future cruelly undone.

THEN there was that other, humiliating physical defeat suffered in fistic combat with Blayle. A fight that came as a result of Blayle's having charged Harper with formerly trying to cause him the loss of Gloria Emory as a pupil and having suggested that Harper was so neatly out of the picture as to make

it foolhardy and dangerous to further meddle with Blayle's affairs or, for that matter, even to speak to the girl. The battle took place right on the field behind a hangar.

It had been only Blayle's braggadocian manner and crowing implications that had enraged Harper, though the crowd of onlookers that had quickly gathered thought otherwise. Allowing himself to be carried away by his wrath, Harper had begun the engagement with a mad rush and a wild swinging, and was knocked down twice before he had struck a blow. His humiliation had been further heightened by Gloria's driving her roadster in upon the scene to stop the fight and give both of them a vigorous tongue lashing, before he had time to get to his feet and back at Blayle.

And thereafter Blayle had continued his crowing, even though it might not have been directly in the presence of Harper. Gloria had continued to be seen more and more in Blayle's company. On all sides the grins, the innuendoes, the jeers, and the fake sympathy had continued. The two who had long been talked about and admired by every one connected with the field as the most charming and best-matched couple, continued separated and talked about. And Freddie Harper had continued to seek more seclusion from the world and sink deeper into the black pit.

The airplane climbed steadily higher, flying in a wide circle around the field. They had reached an altitude of about two thousand feet when next they were over the main entrance and grand-stand corner of it. Instead of continuing in the wide circle, Walsh banked around steeply at this point and climbed northward away from the field. They soon reached the three-thousand-foot altitude that Harper desired and, after they had turned again and were heading on a straight course toward that same cor-

ner, he signaled Walsh that he was about to get out on the wing.

Awkwardly, it would have seemed to an ordinary observer, but yet with a certain hulking dexterity born of countless previous jumps from this same type of biplane, Harper proceeded to get out and into position.

First he stood up on the seat and leaned forward over the cowling in the direction of the nose of the ship. Then he opened the little door with his left hand, while with his right hand he pressed the chest pack, his emergency 'chute close into his body. That was to enable it to clear the edge of the cockpit as he got out, for the door was too small for him and his impedimenta all to go through. Next he put his left leg out and down until his foot reached the wing. Then he reached out and forward with his left hand to grasp a center strut and had to thrust with considerable force against the propeller blast to accomplish this. Then he lifted his body with its cumbersome harness and back and chest packs carefully over the side, and finally drew the other leg after him to stand with both feet together on the wing. There was a breathless moment while he quickly shifted grips and what, to him, had always been the hardest part of the job was over.

He stood there panting a little, with the wind stiffening out the legs of his coveralls and blowing the words out of his mouth as he tried to shout something to Walsh.

Walsh cut the gun and shouted, "Not yet, Freddie! When I nod my head!" Then he gunned her again and the motor's deafening roar cut off all conversation between them.

But there was no need for them to converse. Both knew what to do. They had done it together many times before. And this was to be the last time they would ever again do it together. It is doubtful if Harper felt any pang realizing this, for Walsh,

though one of his closest friends, had been one of those who had been unfeelingly helping to make life miserable for him.

He waited, poised, holding on with one hand. His right hand was at his side. He was facing the tail of the ship.

BECAUSE there was almost no drift that day, Harper was to bail out directly above where he wanted to land. In other words, his descent after he had opened the parachute would be almost perpendicular. And since a good parachutist is supposed to land in the field and as near as possible to the main body of the crowd of spectators, he had decided on a position directly above the grand stand from which to jump. It was indeed easy to spot a jumper well on that kind of a day and Harper, from force of habit perhaps, was going to be good to the last drop.

He felt the wing tilting forward under him as the motor was throttled down and the ship was put into a gentle glide. He leaned over toward the tail and looked down.

Just ahead, framed in the angle formed by wing and fuselage, he saw the corner of the field, two hangars, the office, the restaurant and a small refreshment booth, the crowded grand stand, and the hundreds of little specks that were automobiles. He heard Walsh shout, "Get ready!" flexed his knees, and waited.

Suddenly he felt a firm hand grip his left forearm and hold it tightly. He looked at Walsh.

"The ring! Get the ring, Freddie!" Walsh bawled at him.

Harper looked away quickly. He dared not look Walsh in the eye, even though one might scarcely see the eyes underneath the heavy goggles. He cunningly nodded as if in reassurance but still kept his hand down at his side. He

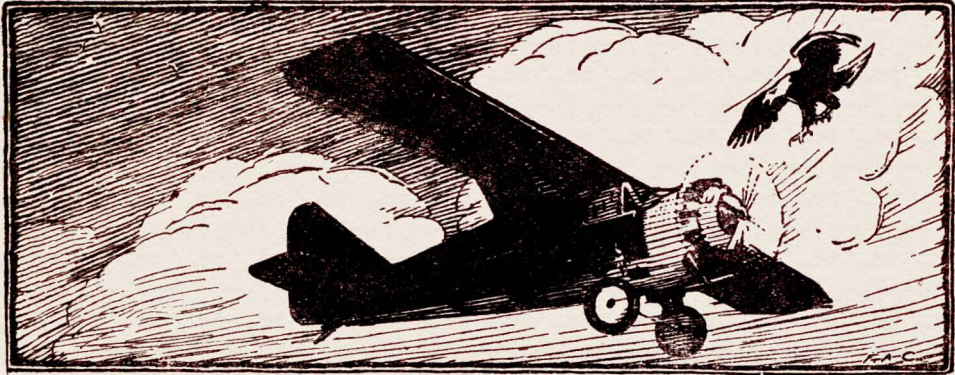

felt the grip tightening and again heard Walsh's excited shout.

"Get the ring! The ring!"

Then he knew that Walsh must have had a faint divination of—something.

Regardless of what it was that Walsh had divined or suspected, what he could not fail to know and see was that the ripcord for the back pack was on Harper's left side, almost under his arm; that stockily built Harper had short arms that just could reach around in front of the emergency pack to get hold of it; that Harper usually slid his arm in behind the riser straps of this pack to grasp and pull it; and that Harper, expert though he was, might have a very difficult task in doing this one way or the other once he had left the wing and was being flung sprawling, over and over, downward.

The grip tightened still more, pinning Harper's arm so firmly to the side of the cockpit that he would have had to fight to free it. He raised his right arm, slid it in behind the riser straps, reached through to his left side and grasped the ripcord ring. The grip relaxed.

"Go!" shouted Walsh.

Harper glanced down, flexed his knees further, and hopped off the wing. Down he shot, but even as he saw the tail being swished out of his way and before the sound of the airplane's motor had left his hearing, he let go of

the ring and flung both his arms wide. He saw the earth coming slowly up to meet him and felt himself turning over. Then he saw sky and a cloud and the sun in that peculiar position it often took when he was doing a delayed drop.

Then suddenly the earth again, nearer. Four! He was counting mentally, from force of habit. Five! Sky again, then the earth. As of old, he thrilled to the friction of the air on his hands and face. Six! More sky. Again, a cloud. More earth—nearer. He was turning over and over more rapidly now. "Getting revolutions," he had once humorously put it. Seven! The earth was very near. He distinguished many things belonging to the field. And then—

In a fleeting instant he saw them—the fools! Eight! Right under him! Right in the way—damn them! Nine! He couldn't do it! He must stop! He must try! Ten! He drew both his arms in, found his body, groped in front of him, found the rough canvas of the emergency pack, and shuffled his hands quickly over its surface until one found the ripcord ring, the fingers closing about it instantly. He tore it from its elastic pocket and pulled with all the strength he could command.

A white shadow shot away beyond his hip and shroud lines flipped his arm. He heard a flapping then a billowing

noise, felt a terrific, jarring jerk, and was snapped into an upright position under a peacefully still, white canopy of silk that supported him and was lowering him gently to the earth.

THERE IT WAS—the earth that had been above and below and all around him. It was safely under his feet now and quite near. Very near. Nearer than it had ever come to him before. He had made longer delays but never any that had taken him quite so low. As soon as he looked down he could distinguish the hands and faces—almost the expressions—of the crowds of people looking up at him. He recognized familiar figures on the field by their clothing. He heard voices from the ground, too—motors puttering, auto horns blowing, voices shouting, the electric voice of the loud-speaker system, and even the shrill note of a peanut vender's whistle.

He was directly over the crowded grand stand. The 'chute was still oscillating and floating swiftly downward. They were still in his way, although he was not traveling very fast now. He reached up, grasped all the shroud lines on one side, and pulled down hard on them with one hand. Then he reached up with his other hand, grabbed another fistful of the same shroud lines, and drew it down almost to his hip. All of which spilled air from the opposite side of the 'chute and caused it to sideslip steeply away from the crowd toward the field.

This made his descent much too rapid for the little altitude he had but he did not let go the lines and have the 'chute assume its normal position until they were well within the field and near the ground. He did not want to land on their heads even now. Before, he had wanted to bury himself in the ground in front of them or go crashing through a hangar behind them, but not to kill or maim any of them.

It was almost a perfect jump. He landed in front of and some thirty yards to the left of the end of the grand stand where the announcer's booth stood, a little over a minute after he had left the wing. As usual he landed on his feet.

It was not necessary to send a car out onto the field to pick him up and bring him in. He was not far enough away for that. A group of pilots and field attendants ran to his assistance, helping him to unbuckle the parachutes and gather the opened one up in orderly fashion. They chanted praises as they clustered about and fussed over him. Gruffly he thanked them, picked up the huge bundle of silk, and walked directly toward the operations office.

There was the usual honking of horns, whistling, cheering, and hand clapping, only this time it was louder and more vociferous than he ever had heard it before. He completely ignored it, however. He did not want any applause that day. All he wanted was to get away by himself.

The little group about him tried to crowd him over to the grand stand. He had to push some of them away forcibly to make his way toward where he wanted to go. He was angrily conscious of the all-powerful, megaphoned voice of the field announcer, a voluble combination of sight-seeing lecturer and master of ceremonies, begging the slowly dispersing crowd to wait a few minutes while he tried to get Mr. Harper to take a bow and say a few words to them about the thrilling jump he had just made.

"That was some long delay you made, Freddie, old boy," he said, speaking directly to Harper by way of the loud speaker. "Come on over and tell the audience all about it. I promised them a thousand-foot free fall and you gave them a two-thousand or was it a three-thousand-foot delay. How high were

you? Come on over and say a few words to your public.

"Ladies and gentlemen, Mr. Harper has probably hurt his foot or pulled a tendon or something and is now going into the office to look after it. Something must be wrong as there is a frown on his usually smiling face. However, it can't be very serious and, as soon as Fearless Freddie comes out of the office again, we will have him come over to the microphone and say a few words to you. I know you will all want to hear from him when I tell you that this was Freddie's last jump here.

"Whether he intends to leave us entirely and go to another field or whether he intends to remain here just taking care of his parachute-service station and leaving out these exhibition jumps, I do not know. All I know is that he has been saying—uh—around here—uh—that this would be his last jump here. We may get him to tell us himself just what his plans are, so don't go away. In the meantime, we still have two seats left in the Skylark you see here in front of you on the line, waiting to take off for a sight-seeing trip over beautiful green—"

But Harper was inside the operations office breathing a deep sigh as he turned away from the closed door that shut out the rest of the monologue and the sound of the applause that he once loved to hear. It also effectively halted the annoying group that had been tagging along after him. He placed both his parachutes on the floor behind one of the two wooden railings that made an aisle through the middle of the office.

EGERTON, the field manager, was alone in the office except for a girl clerk typing near a window. Harper returned the girl's smiling greeting with a curt nod. Egerton was talking into a telephone on his desk.

"N-no-o. No-o," he was saying slowly. "Y-yes, perfectly safe. Wasn't

hurt a bit. N-no, nothing. Ha, ha! Yes. That's all right. Good-by." He hung up and, having watched Harper come in, turned to the parachutist. "That's a good one. Party called up from over Lincolnville way and wanted to know who the poor fellow was who just got killed jumping out of an airplane. Saw you falling into the valley but couldn't see any 'chute opening. And that's the second one that called about the same thing. Say, watcha been doing out there, young feller? I should have been watching. I think I'll just run out and see how they're all taking it."

He pushed his chair back from the desk and started to go out. His hand grasped the doorknob just as the telephone rang again. "Hah! Another one, I'll bet. You answer it, Freddie, and tell them that it was you and you're not killed or hurt." He went out.

The phone kept ringing. Harper noticed a frown of perturbation beginning to appear on the girl's face. He walked to Egerton's desk, picked up the receiver, said "hello" mechanically into the mouthpiece, and waited.

He heard a voice, a tremulous feminine voice, saying, "Hello, is this Snowden Field?" It was a voice that he recognized!

His own voice was husky with a sudden nameless emotion as he answered, "Y-y-yes. Wh-what is it, please?"

The voice said haltingly: "I—I want to find out—about—Freddie—Mr. Harper—Freddie Harper. Is he—is he—all right?"

"Why-why, er—who is this calling, please?" Harper asked. This time he intentionally kept his voice husky.

The voice at the other end became frantically insistent. "O-oh, tell me—please! Why don't you tell me? Is he—is Freddie—hurt?"

Harper perhaps could not have explained his reasons—he probably did

not know himself why he did it—but he insisted on an answer to his question.

"Well, er, who is this?"

"I'm—I'm—— I'm his—his——"
Oh, I love him! I love him! Tell me quickly! What has happened? Did—did he——"

"Wh-wh-why—er—nothing! I mean nothing's happened to him, ma'am—er—lady. I'm—he's—it's—er—we——"
He stopped talking and took a breath because he knew that he had been spluttering. Then he went on more evenly, still maintaining the tonal disguise, "Freddie Harper is safe and sound. Wasn't hurt a bit. Just pulled one of his stunts, that was all. Who—— Oh, good-by." Having heard a sobbing sigh of relief, he had ended the conversation abruptly and hung up with a bang.

He whirled around, swayed a little as though dizzy, and looked all about him. For the first time in two months, he wanted company—people, friends, anybody—to hug or slap on the back. His glance rested on the girl for a second. She was still busy typing and still frowning. She must have appeared too frail besides.

He dashed outside, saw Walsh standing near by talking to two other pilots, and went over to them. Coming from

the side, he gripped the astonished Walsh in a choking bear hug, freed him, and then smote him lustily on the back.

"*Whouf-f-f!* Ow! Sa-ay, what's the meaning of this, Freddie?"

"Oh, nothing. Just feeling good, that's all," Harper answered. "How are you, yourself?" He drew back with his strong right arm and gave Walsh another playful blow, one on the shoulder that made the pilot stagger.

"*Owooo!* Hey, what are you trying to do, kill me?" Walsh yelled. "I thought Blayle took all that out of you?"

"Oh, yeah? Still at it, I see. Well, that stuff doesn't bother me. Goes right over my head. And the next time you see Blayle, you can tell him that I said I'm going to make him lose a student all right and if he wants to do anything about it to come and see me. And if anybody should ask you, I'm not getting out of town either. I'm staying right here at Snowden Field. Well, I think I hear the old demon announcer still paging. Getting a big hand on my last jump, aren't I? See you later."

And Freddie Harper turned away and went to greet his "public" wearing, for the first time in many weeks, a great big smile.

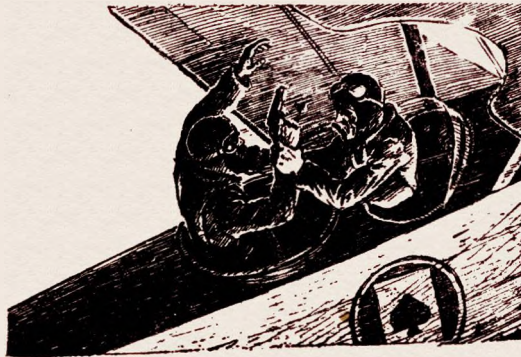

DO YOU KNOW THAT—

Tests of a newly developed fuel in actual flight show that it raises the horse power of airplane motors from 20 to 30 per cent; at the same time it reduces the corrosion on the engine?

Improved passenger accommodations on national air lines have largely eliminated fear, at one time the greatest cause of air sickness?

Air freight carried by American air lines totaled 3,449,675 pounds in 1934, almost half again that carried in 1933?

A new "bent-beam" system for blind landings has been perfected, which can be installed underground in the flying field, and provides a definite path of descent from any direction, accurate to within fifty feet laterally, and five feet vertically?

The United States navy has ordered 84 Chance Vought scout bombers, equipped with Pratt and Whitney engines and Hamilton Standard propellers, whose cost will total \$2,500,000?

A new 30-watt radio beacon transmitter has been installed by Station WOR—one of the first to be operated by a commercial broadcasting station?

Arrangements have been made by the British air ministry to purchase the Comet, the plane in which Scott and Black won the England-to-Australia air race, for the purpose of using it in a series of experiments which, it is hoped, may yield useful information? This ship uses two engines of only 224 horse power each on a total weight of 5,250 pounds, yet has a top speed of 235 miles an hour.

The few accidents which commercial aviation has had have been caused, in the order of their importance, by ice, low ceiling, poor visibility, heavy precipitation, bad fields due to rain and snow conditions, thunder storms and squalls with violent vertical currents, squalls and turbulence near the ground, head winds so continuous as to exhaust fuel, and lightning?

Japan has just added to her fleet a low and taper-winged monoplane with twin liquid-cooled engines and a double-rudder tail, said to be capable of 200 miles an hour?

American air-passenger lines flew 592,802 miles per accident in the last six months of 1934, nine per cent more than in all of 1933; and the passenger miles flown per passenger fatality were 26,339,197?

Clem Sohn, delayed parachute jumper, has been experimenting during jumps with crude "wings" and webbing between his feet; and has been able with them to check his descent for 12,000 feet by zooming, making climbing turns, and even looping, before pulling the rip cord of his 'chute?

Over eleven million words were spoken in 1934 between seventy American air lines transport planes and forty-three ground stations—an average of twenty-one words for each minute of the year—and all in the line of duty?

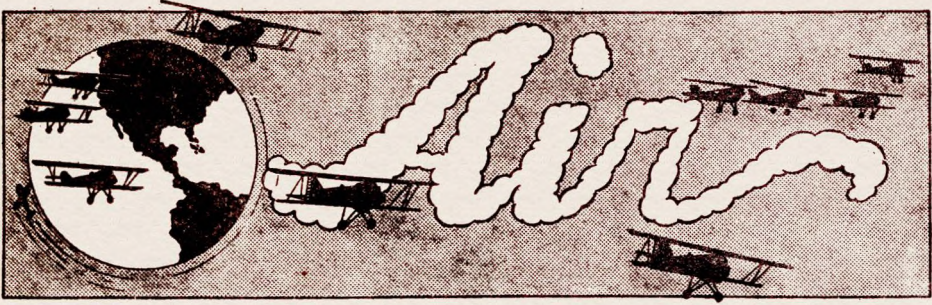

An Organization for the

AIR ADVENTURERS, fall in!
Lively now! Drop that
model! On the double! Snappy!
Snappy!

Dress up your ranks!
Count off!

You do so, squadron after squadron,
in all your thousands. Very good.

Air Adventurers, attention!

Last month we had our first inspection. This month I am going to give many of you your first order.

This first order is extremely important. Many of you—a very great many of you—have asked me in your letters how you can be of real and immediate service to the cause of aviation. I am going to tell you. Listen carefully. My words, and what you do about them, may save the life of an aviator. Or five. Or fifty!

Suppose you are piloting a plane and run into fog so thick and general that you get lost. Suppose you circle for a long time, as low as you dare, hoping for sight of something that may give you a clue to the direction of an airport. You circle for hours without sight of a place you dare try set down on—circle till your gas is all but gone—until, in the last few minutes, straining, straining with your eyes, you make out, below, the rooftops of a little country town. At this your face will light up, hope will tug at your despairing

heart again, and eagerly you will spiral lower for a better look.

A little town. Several hundred buildings. But you find you can't recognize a single one of them through the fog! Perhaps you have never been over that place before! Not one rooftop tells you where you are! You are probably within several miles of an airport, but it might as well be a million, for you don't know which way it is.

Then what?

Oh, you'll get down, all right! In some one's cornfield! But you'll crash doing it, and maybe—well, maybe if you're lucky you'll only go to the hospital.

Fellow Air Adventurers—you who have wanted to know what specific, immediate thing you can do in the service of aviation—attention to this order!

GO to the leading citizens of your city or town and ask to have its name painted on the largest rooftop, and also an arrow pointing north, with an "N" standing above the end of the shaft at right angles to it; or, if there is an airport near by, an arrow pointing in its direction with an "O" similarly placed.

Ask them to do this. If they won't, you will at least have done what you could, and I'll be proud of you. But many will do it. Good! You Air Ad-



Advancement of American Aviation

venturers who are successful will report that fact to me.

Who will go to a little trouble to help save a fellow airman's life?

Who will do his bit to help prevent a needless crack-up?

Who will help extend this minimum courtesy to our pilots, to aid them in keeping on their course?

Air Adventurers, this suggestion is not mine. It comes from our distinguished fellow member, Clyde Pangborn.

Thanks to you, Clyde! Wait! See what our club members can do! Wait and see!

Now, New Readers, attention! Our Air Adventurers Club is made up of the finest group of air-minded young

men in the country. You are cordially invited to join us—but only if you can sincerely sign the coupon below. Not otherwise! If you do feel at one with us, fill it out and send it to The Flight Commander, Air Adventurers, 79-89 Seventh Avenue, New York, N. Y., together with ten cents to pay postage and costs; and we shall carefully consider your application and, upon approving it, mail you your badge and membership certificate.

Welcome, New Members!

To work, Air Adventurers!

Fall out!

Albert J. Carlson

FLIGHT COMMANDER.

(MEMBERSHIP COUPON)

I am interested in aviation and its future developments. To the best of my ability I pledge myself to support the principles and ideals of AIR ADVENTURERS and will do all in my power to further the advance of aviation.

Please enroll me as a member of AIR ADVENTURERS and send me my certificate and badge. I enclose ten cents to cover postage.

Name..... Age.....

Address.....

.....

Check here if interested in model building.

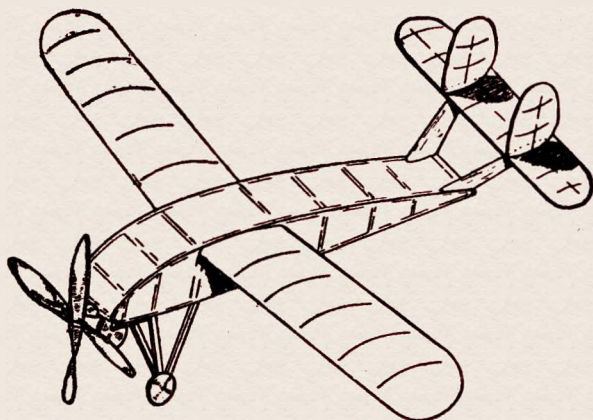

Contest Models

by GORDON
S.
LIGHT

This is the most practical model department for real builders in any aviation magazine. Follow it every month and save your copies.

THE TYPES of model airplanes flown to-day are probably older than most of the boys who fly them. The early model builders thought of just about every type of model. Twin pushers, single tractors, single pushers, fuselage models—all had their beginning before the World War. All that we present-day builders have been able to do is add to the knowledge of these pioneer modelers and improve their methods of construction.

The first model airplane contests were conducted in the early 1900s, soon after the Wright brothers made their famous flight. Beginning with 10-second flights, model builders began to climb the ladder of better flights until to-day they've reached the dizzy heights of quarter-half-hour flights.

In boosting records, many different types of models have played active parts. The single pusher (drawing #1) was one of the first contest ships. It was developed back in 1909 by Percy Pierce of Philadelphia. With it, he set an American record of 200 feet. Since that time many different types of single pushers have appeared. It has become a favorite with beginners because it is easy to build. Since Pierce's time it never figured very much in contests until Harry Edsal brought out his single pusher in 1933. He began winning contests with this ship, running up the remarkable time of 8 minutes.

It was a small model with a 30" wing, 30" motor stick and a 12" propeller. The motor stick, 1/2 x 1/2 x 30", was built up of four pieces of sheet balsa.

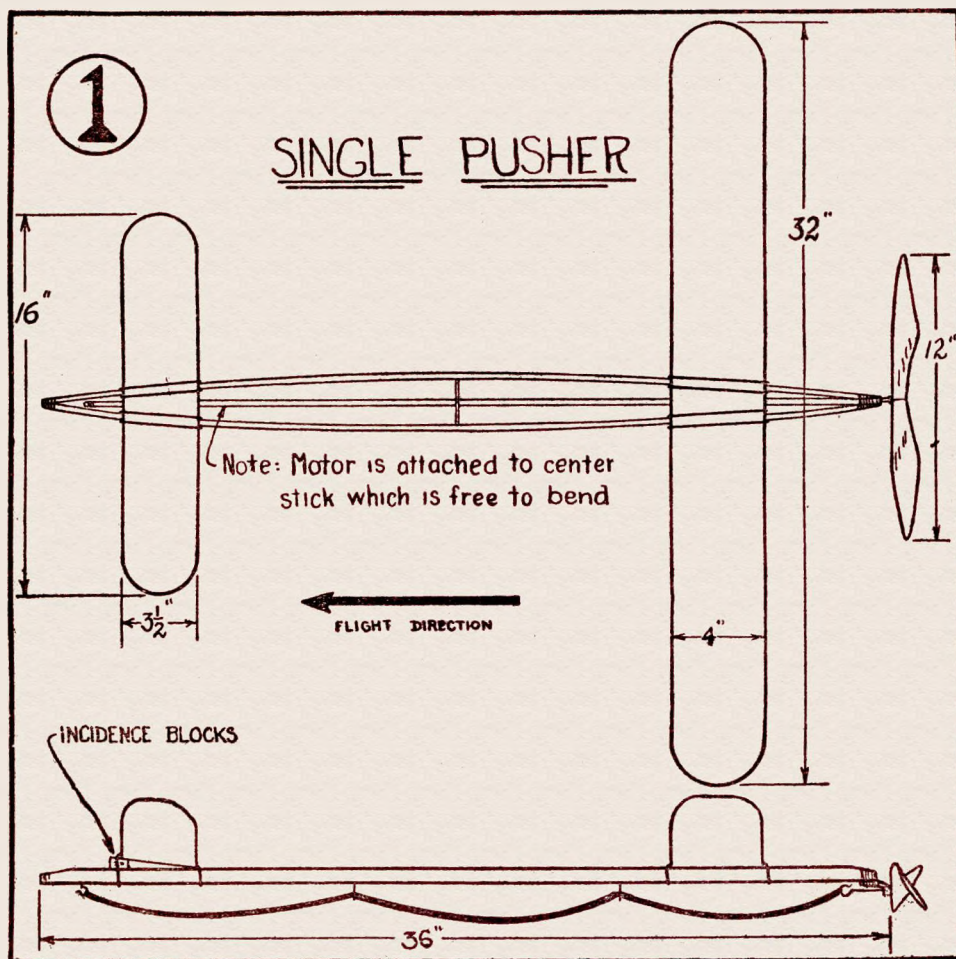

Ten strands of 1/8" rubber powered this ship. This single pusher has a steep climb and a flat glide. It handles easily in rough air and is not unwieldy to launch. The great number of these ships at last year's contests show it is rivaling the popularity of the old favorite—the twin pusher.

In 1911, Cecil Peoli of New York City flew a stick-model airplane powered by two motors. It traveled 1691 feet and stayed in the air 49 seconds. Peoli's ship was the ancestor of the twin pusher—the type of model that was destined to dominate contests for the next 24 years. Some of the builders who made the

twin pusher famous were R. F. Mann of England, Joseph Lucas of the Illinois Model Airplane Club, Armour Selley of Brooklyn, New York, and Wallace Lauder of the Aero Science Club of New York City.

However, the king-pin in twin-pusher development was Robert Jaros, who turned in a flight of 10 minutes, 14.2 seconds in 1924. By 1928 long twin-pusher flights were so numerous that it was necessary to add weight to the models to keep them from flying away. A weight requirement of one ounce for every fifty square inches of wing area was set up by the National Aeronautic

Association. This ruling cut down the length of the flights to about $7\frac{1}{2}$ inches but improved the "breed" of twin pushers. They became more rugged in construction and less dependent on rising currents. The outline drawing, #3, shows the proportions of the present-day twin pusher.

SOME of the builders prefer to place their contest hopes in twin tractors rather than in twin pushers. Drawing

#2 shows the general outline of this type. In respect to performance, it is a toss-up between the twin tractor and the twin pusher. Charles H. Grant, old-time modeler, back in 1930 flew a twin tractor that closely rivaled any twin pusher. Its steep climb and stable flight in a 30-mile-an-hour wind showed that the twin-tractor design, if properly worked out, is always a contest threat. Grant's tractor varied a little from the type shown in drawing #2 since the

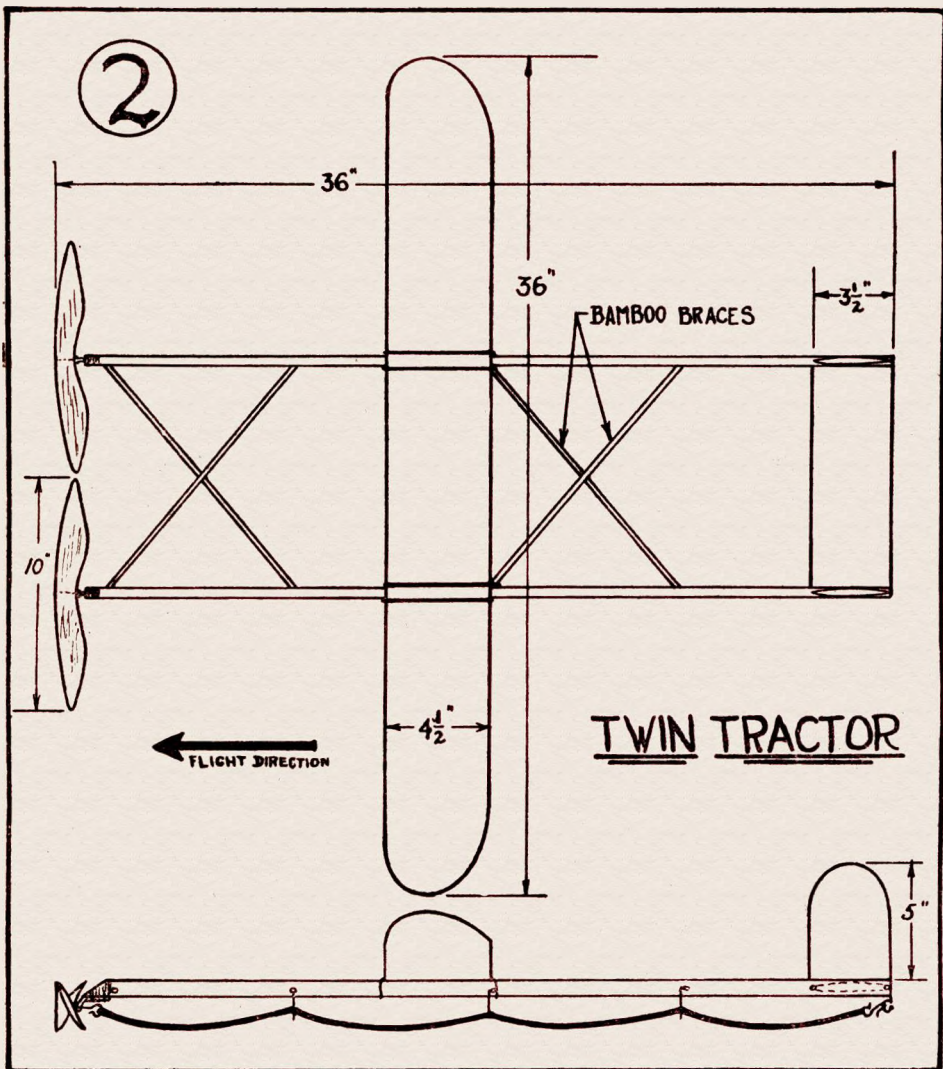

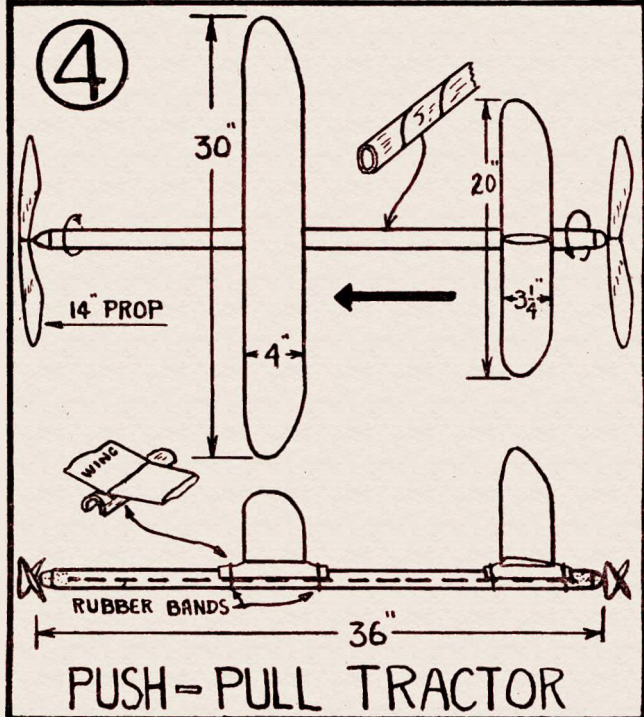
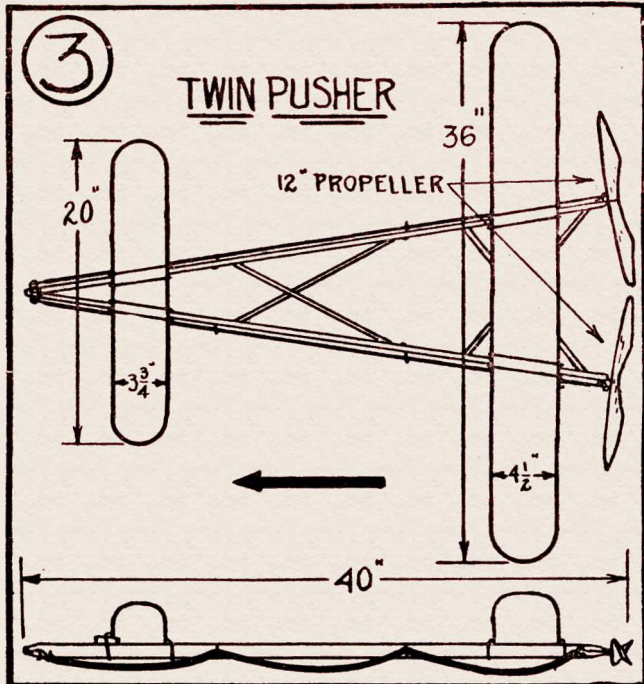

motor sticks were joined at the rear in a V shape. The tail group was built up as a separate unit instead of forming a part of the motor-stick supports. In addition it was equipped with a landing gear.

Single-motored tractors, the best bet in any indoor contest, never shared heavily in outdoor prizes until 1934, when a single tractor won the national outdoor endurance contest at Akron. It was flown by Vernon Boehle of Indianapolis, who had won previous contests with twin pushers. He intended to use twin pushers at Akron, but the test flights were disappointing. He wanted a better model for the contest. His choice was a single tractor. It must have required considerable courage to abandon the reliable twin pusher in favor of the single tractor, which had never distinguished itself in important contests. It proved to be a good risk—Boehle flew his single tractor to a new endurance record of 15 minutes.

Specifications of Boehle's ship are: wing span, 36"; overall length, 33"; rubber length, 25", maximum fuselage cross section is triangular $2\frac{1}{8} \times 2\frac{1}{2} \times 2\frac{1}{2}$ "; propeller, 17"; total weight, $2\frac{1}{2}$ oz. There was no landing gear on Boehle's ship. The fuselage was triangular, built up of balsa longerons and covered with tissue. The motor was inclosed in the fuselage. This idea of using a built-up fuselage to carry the strain of the rubber motor was the main feature of Carl Leja's 1929 tractor. This ship was a trifle smaller than Boehle's and was much lighter in weight. The wingspan was 32", motor and fuselage length 25", propeller 11", maximum fuselage cross section was a triangle $1\frac{1}{16} \times 1\frac{1}{4} \times 1\frac{1}{4}$ ".

Using a built-up fuselage to carry the strain of the wound motor is a good idea in single tractors. An ordinary balsa motor stick is certain to bend under full winds, throwing the wing and tail out of alignment and causing

the ship to dive or stall at the beginning of the flight. However, the method used in the single pusher in drawing #1 can be adapted to use in a single tractor.

In this design, the wings are not attached to the motor stick but to a bow-shaped frame. The motor stick is securely attached to this frame at the propeller end, but the other end is secured with rubber bands so it is free to twist and bend without disturbing the wing and tail settings.

A third way of overcoming the bending of the motor stick is to mount the elevator rigidly to the wing by means of booms or outriggers, then clip the wing on the motor stick. This leaves the stick free to twist, yet the tail and wing are permanently adjusted. This type of model was successfully flown by Walter and Dean Gardner of Maryland.

An interesting combination of the pusher and tractor is the push-pull tractor shown in figure #4. It is still in the experimental stage. All models of this type that have appeared at contests proved to be good climbers and stable fliers, but usually the glide was poor. It is still too unreliable for contests, so most modelers discard it in favor of the conventional tractor. This type ship has contest possibilities. The poor glide could be remedied by setting the front propeller shaft at a negative angle. This would allow the main wing to be moved farther forward, and would flatten the glide without causing any trouble when the ship is flying under full power. Also, the relative sizes of the elevator and wing determine its flying ability. Too little is known about the push-pull tractor to determine whether it is as efficient a model as other contest types.

CONSTRUCTION of the push-pull tractor is slightly different from either the single tractor or pusher. The fuselage is a balsa tube made by wrapping sheet balsa around a piece of dowling.

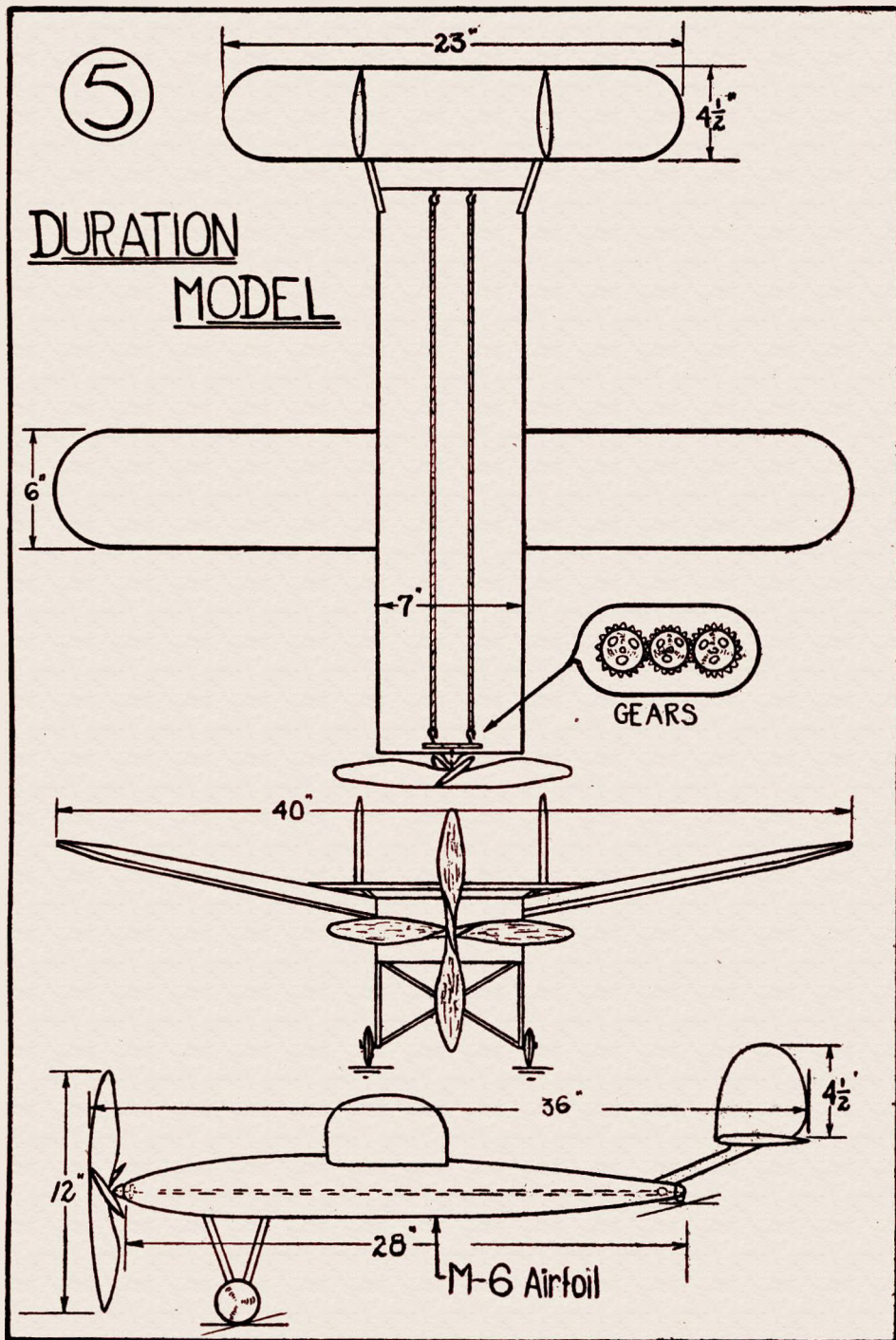

Both propellers are run by the same motor, the right-hand propeller being in front, the left-hand in the rear. Mounting the wing to the tubular fuselage is easily done by first cementing it to a rounded piece of balsa the shape of the outside of the motor tube, then attaching to the fuselage with rubber bands.

The weight rule of 1 ounce per 50 square inches of wing area applies to fuselage as well as stick models. Since weight handicaps a model, designers are continually trying to increase lift without being required to increase wing area. The solution of this problem seems to be a model patterned after the large-size Burnelli transport. The model shown in drawing #5 has a fuselage shaped like an M-6 airfoil. The calculated wing area is 200 square inches, making the required weight 4 ounces, but the fuselage also contributes to the lift. Fortunately the rules don't include airfoil fuselages in calculating area, so the 200 square inches of fuselage area don't raise the total weight of the ship. In other words the wing loading is actually about 1 ounce to every 100 square inches or one half the requirement of the rules.

The model is equipped with a four-bladed propeller turned by two rubber motors connected by gears. The outside gear wheels are slightly larger than the gear on the propeller shaft. This speeds up the propeller and increases duration.

The big advantage of this type of gearing, however, is the use of two small motors instead of one large one. A motor with a few strands can be wound many more turns than a heavier motor. Gears in models are almost as old as the model-hobby itself.

About 1920, the well-designed models were almost certain to have gears. With the return of heavier models, gears are again becoming useful. This year's crop of contest ships is sure to include many geared models.

In the past, models with airfoil fuselages proved to be unstable unless care was taken in picking the wing section for the fuselage. The section must have a stable center of pressure location. That is, the forces of lift and drag must always act through the same point regardless of the angle of incidence of the wing section. The Munk airfoil, Number 6, is such a section. The center of pressure location does not vary any appreciable distance in a range of angles from 0 to 20 degrees.

NEXT MONTH, we'll tackle a model of the Crusader, a new high-speed twin-engined ship. The Crusader is a new design. A tear-drop body is at the center of the wing. The two motors are located in the leading edge of the wing. The tail is mounted on two booms extending from the wing. The high speed is 233 m.p.h. Watch for this dandy flying model.

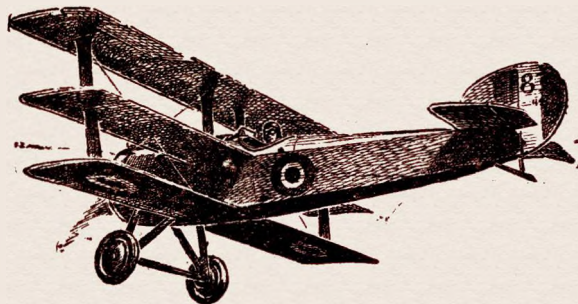

Residents of New York City should include the 2% sales tax for unemployment relief.

An Exciting Start for an **IDEAL LIBRARY**

FICTION'S MOST FASCINATING FIGURES

EACH
25¢ *The SHADOW
and
DOC SAVAGE*

30c by mail

Three Different Books.
Three Amazing Adventures.
Three Sensational Bargains.
Three Varied, Vivid Themes.

1. **The Living Shadow**
2. **The Man Of Bronze**
3. **The Eyes Of The Shadow**



Two Hundred and Fifty Pages of Exciting Adventure. Attractively Bound. *Only Twenty-five Cents Each.*

At Your Book Shop or News Stand

If your dealer cannot supply you, purchases can be made direct from Street & Smith Publications, Inc., 79 Seventh Avenue, New York, N. Y., by enclosing an additional 5 cents to cover mailing cost.

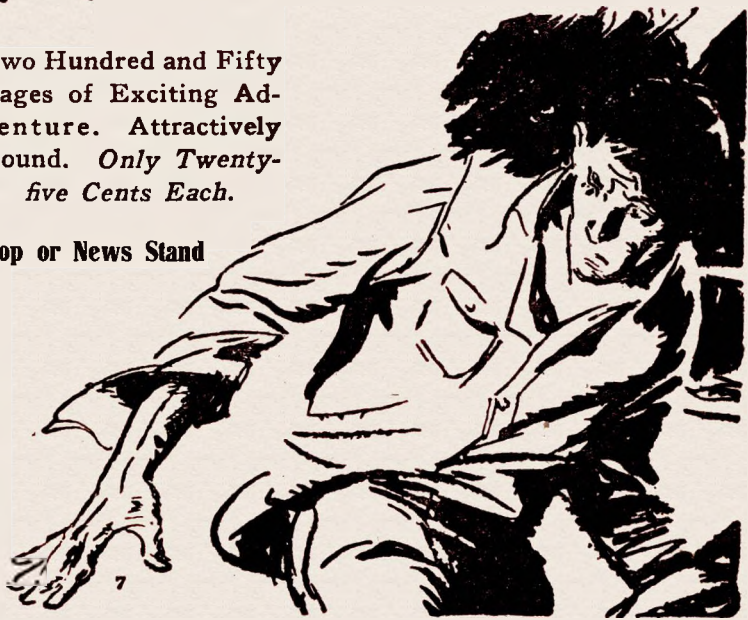

What's Your Question?

By **CLYDE PANGBORN**
Wing Commander



The wing commander of the Air Adventurers will answer such questions as appear to be of general interest to our members on this page as soon as possible after the questions are received.

Question: Why aren't triplanes ever built any more?

Answer: Monoplanes and biplanes are more efficient in flight, and are structurally stronger.

Question: Can a bird shatter a plane's propeller and force it down?

Answer: It certainly can.

Question: Who came in fourth in the London-to-Melbourne air race?

Answer: Lieutenant Cathcart Jones and Ken Walker, of England.

Question: Do you believe in allowing beginners to fly their own home-built planes?

Answer: As a rule, no. Far too many have been killed.

Question: How is it that planes are not equipped with markers, such as kites or small balloons, which could be sent up after a crash to draw searching parties to the spot?

Answer: I don't know if this idea has ever been seriously considered, but I should think not, for these reasons: A kite would not be easy for injured men

to fly in the wooded, hilly country where crashes are most apt to occur; and a balloon would bring the need of carrying means to inflate it, and the problem of doing it under distressing conditions—for no balloon of any size could well be carried as standard equipment by all aircraft. Then, neither kite nor balloon would be very visible to searchers against the terrain below.

Question: Who was the first man to fly to the North Pole?

Answer: Admiral Byrd.

Questions: (a) Are auto-gyros easier to fly than ordinary planes? (b) Are they so very much safer?

Answers: (a) Yes, but they maneuver somewhat differently and one must get used to them. (b) Yes. The one great danger inherent in all ordinary planes is the inevitable stall which comes when the ship slows down beyond a certain point—usually around 55 miles per hour. It is the stall which usually starts planes into tail spins; it is the comparatively high-stalling speed that makes it necessary to land at a speed higher than that speed, and requires so much field room.

The auto-gyro cannot stall while its vanes are turning—and they are always turning while the ship is in flight. This is true even when there is engine failure, for, except for starting the vanes in motion before taking off, the engine is never engaged with them. As a result, the auto-gyro is almost foolproof in the air, and it can set down on a small spot and at a low speed that would wreck any other plane.

Question: How many air-transport lines are there in the United States?

Answer: At the end of 1934 there were 103.

Question: What is meant by visibility?

Answer: It might be called the clearness of the air. It is measured by the distance at which prominent objects can just be discerned. Among the factors affecting it are condensations such as fog and clouds, precipitations such as rain, snow and hail, and artificial products such as smoke and haze. The scale used by the United States weather bureau, and adopted by the International Commission for Air Navigation, is:

Scale	Description	Limiting Distance
0	Dense fog	55 yards
1	Very bad	220 "
2	Bad	550 "
3	Very poor	1100 "
4	Poor	1¼ miles
5	Indifferent	2½ "
6	Fair	6¼ "
7	Good	12½ "
8	Very good	31 "
9	Excellent	beyond 31 miles

Question: What do you think of the future of the airplane?

Answer: Great! No end to it! Why, in a few years we'll be spanning the Atlantic in five hours!

Question: Please tell me what taxiing means.

Answer: Taxiing is moving an airplane over the ground under its own power. It is always, when possible, done at low speed—say, from 5 to 10 miles an hour.

Question: How many times have American fliers won the Schneider Cup?

Answer: Twice. In 1923 and 1925.

Question: Is there much of a shock when a parachute jumper hits the ground?

Answer: Not so much for an able-bodied man. About what you'd receive in a jump from a six or eight-foot wall.

Question: Just what constitutes safe flying?

Answer: Plenty of air speed and a proper attitude of the plane. The conservative pilot flies high and fast, his altitude permitting a long glide to a safe landing place should his motor fail, and his speed preventing the possibility of the stall, which leads to the dangerous spin. All but the normal attitudes used in taking off, climbing, turning, landing, are considered acrobatic flying, which is illegal with paying passengers.



The Corsair Junior

Vought's All-Purpose Military Land Plane

A NEW light airplane has been added to the famous Corsair family—the “kid brother” of them all—but a kid brother whose fighting merits easily allow it to take a place by its older brother’s side. Friends, meet the new V-100.

You may remember that the original Corsairs were designed to provide a land-type plane that could be quickly changed to a seaplane without loss of strength, maneuverability, and flying efficiency. In later models this flexibility was extended to make the Corsairs readily changeable from a plane of one combat type to another—from an observation ship into a bomber, or into a scout, or an attack-type plane—all with a minimum of time and labor. The latest addition carries on this all-purpose idea.

The V-100 is a two-seater biplane designed particularly for light military operations, and carries as normal equipment, a fixed machine gun, a flexible machine gun, and provision for the ready installation of standard bomb racks; and for special military missions it may be equipped with aerial camera, radio, camera gun, and apparatus for blind flying.

All these useful load installations are patterned after similar ones in the standard two-seater Corsair, which have proved themselves in hundreds of planes operated in the military services of the United States, several South American countries, Great Britain, China, and Japan. And all of this equipment may readily be installed or removed, so that the Corsair Junior may quickly be made

ready to perform any of its many functions.

Structurally, this plane is similar to the standard Corsairs, but smaller and lighter. The wings are of wood, fabric-covered, with straight unrouted spruce spars and simple wooden ribs. The tail unit is constructed of welded chrome molybdenum steel tubing, fabric-covered, and is identical in design with that furnished on many Corsairs for the U. S. navy. A welded steel tube fuselage is employed, with quickly detachable metal cowling forward of the cockpits, making it possible to lay bare the entire fuselage for overhaul, without the necessity of recovering.

The landing gear is of the oleo-spring type, and is interchangeable with a single-float seaplane gear. A standard swiveling oleo tail wheel is used.

The engine is the Pratt and Whitney Wasp Junior, Model SB, capable of developing 400 horse power at 2200 R. P. M. at 5000 feet. It is equipped with pressure baffles, N. A. C. A. cowl, Stromberg carburetor, Scintilla magneto, carburetor air heater, oil temperature regulator, fuel pump, radio shielding, and exhaust stacks.

A Hamilton Standard metal propeller is used, and the engine compartment is fitted with a Phister pressure-type fire extinguisher. Eighty-eight gallons of fuel are carried in two main tanks mounted in the latest type of cushioned supports, and 6 1/2 gallons of oil in a welded aluminum tank.

The Corsair Junior has complete dual engine controls, instruments, and surface controls, except that there are brakes on

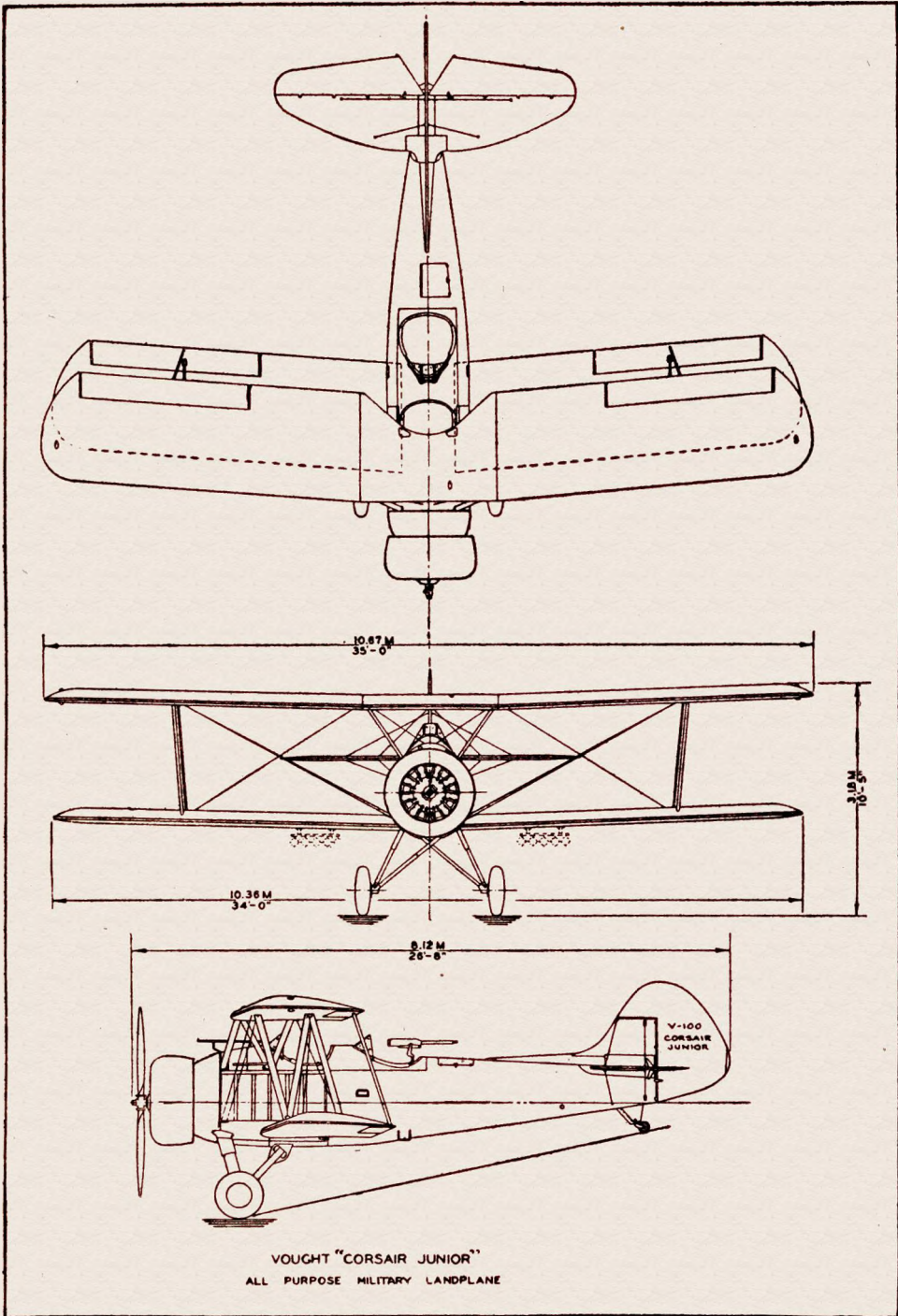

the front pedals only. The seats and rudder pedals are adjustable, and the rear seat and rear control stick are removable when it is desired to use the rear cockpit for other purposes.

OF special interest is the new flexible gun mount. It is of the combined post-and-track type, extremely sturdy and simple in construction, and permits easy and rapid movement of the gun to all possible firing positions. Its use eliminates the heavy and cumbersome Scarff ring, and makes possible a much cleaner and more compact rear cockpit design.

The fixed machine gun is mounted in the fuselage and synchronized to fire through the propeller circle. It is mechanically operated by means of a trigger on the front control stick. An ammunition box for 500 rounds of ammunition and ejection chutes for the cartridges and links are provided aft of the fire wall, and an open sight is installed on brackets above the fuselage forward of the pilot. Both guns are the latest model MG-40. They may be chambered for ammunition of half a dozen calibers; and both installations may readily be set up and removed.

The bomb racks may be mounted under the lower wings. The bombs are released from the front cockpit, where release handles and an arming and safety handle are installed. Each rack will carry five 17-pound bombs, or five 25-pound bombs, or five 30-pound bombs, or two 116-pound bombs. The fixed sight for aiming them is the same as that used for the fixed machine gun.

Provision has been made to allow the installation of one Fairchild CG-16 camera machine gun, mounted on the center section and operated by the same trigger on the control stick that operates the machine gun. This camera gun is of the latest type and uses 16 mm. film. It may also be mounted on the flexible gun mount. For aerial photography the

plane may be equipped with a Fairchild K-3B camera, mounted aft of the rear cockpit for operation by the observer. This camera is electrically operated, and may be used only when the plane is equipped as a landplane, as the seaplane float interferes with the field of view.

Also in the rear cockpit may be set up a short-wave transmitting and receiving radio set especially designed for the plane by the Western Electric Co. It is of 10-watt carrier power, transmitting on any pre-selected frequency between 45 and 100-meter wave length, and has a normal operating range of from 50 to 125 miles.

To complete its functional versatility, the Corsair Junior is well suited for a trainer. Flight tests conducted by men ranging in ability between highly skilled test pilots to students have brought the unanimous report that it was easy and comfortable to fly, that its behavior was normal in take-off, straight flying, and landing, and that it performed all maneuvers easily and with an ample reserve of power.

The performance of the Corsair Junior as a landplane, based on flight tests, is as follows:

Maximum Speed at		
5000 Feet	155	m.p.h.
Landing Speed	54.3	m.p.h.
Rate of Climb (Sea Level to 5000 Feet)	1030	ft./min.
Service Ceiling	20500	feet
Cruising Range	564	miles
Weight Empty	2405	pounds
Normal Useful Load	1154	pounds
Normal Gross Weight	3559	pounds

How'd you like to fly this plane?

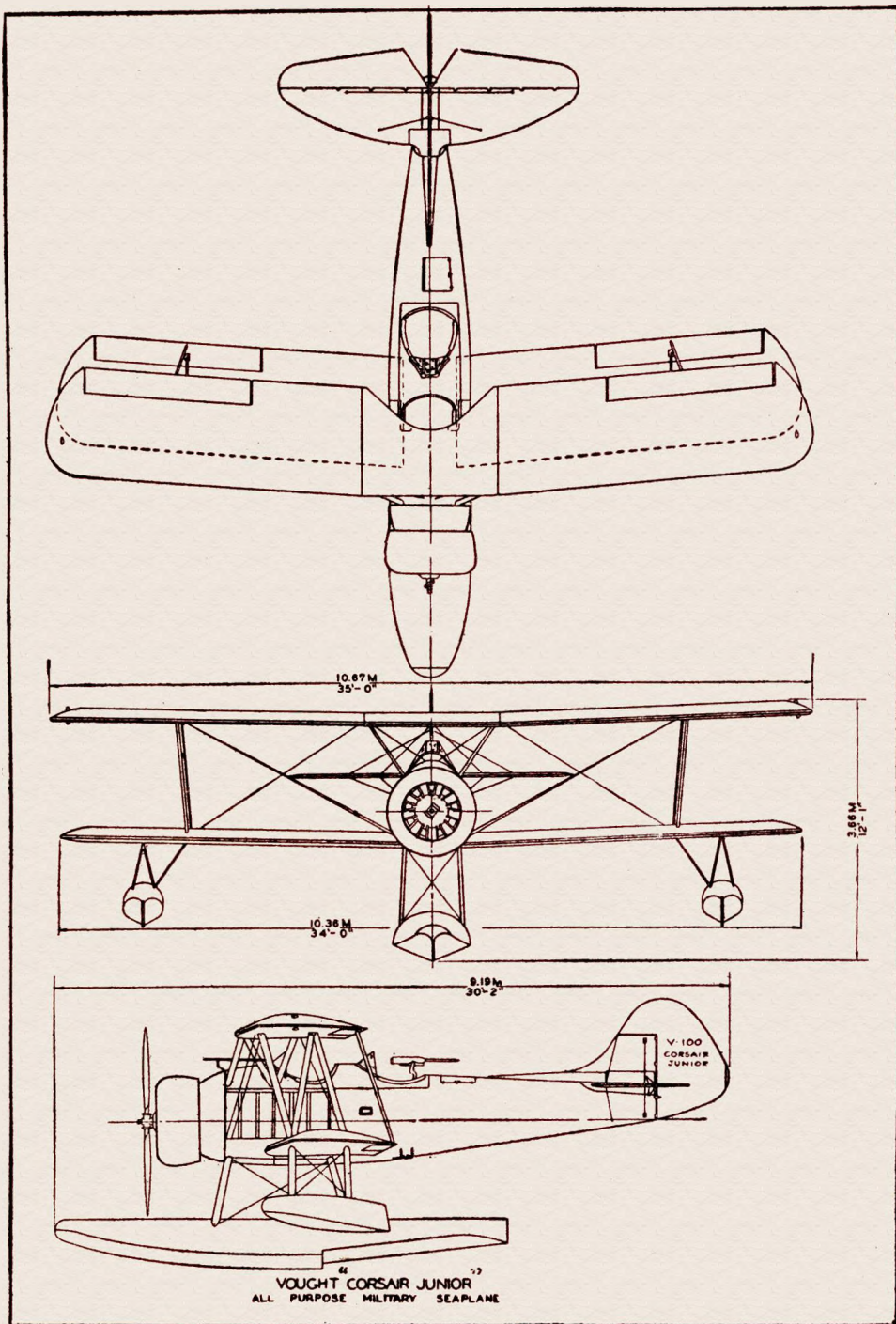

A life sketch of

"CY" HAWKINS

Air Adventurer

by Frank Tinsley

IT WAS just a couple of days past "Cy's" sixteenth birthday that "Buck" Cheever handed the kid the newspaper photo of the famous Yankee flier and his pinto plane. From that exact moment young Cyrus Crook Hawkins was hipped with the idea of flying.

The War had been dragging along for two years but fighting was still a hazy and distant thing to Cy. After all, what could a kid brought up on a secluded ranch in the Texas Panhandle know about the momentous European conflict? Except for an occasional week-old local newspaper left behind at the bunk house by some passing rider, the only news received at the ranch was ordinary word-of-mouth gossip that had been altered by repetition until it bore no resemblance at all to the true and original facts.

"I understand," one of the boys would say, "that them Frenchmen and Dutchmen just up and fit another battle. Yep. Met one of the Q-Cross boys out at Stinking Springs and he allowed that 'bout a million of 'em on each side been rubbed out in a fight over a piece of range. Four hundred yards, the paper said. Reckon them European fellas must be plumb loco, killing off such a heap o' hands over a little patch o' range like that."

The waddies of the Hawkins spread

would shift their cuds and wag their heads in agreement.

"Yes, suh! Sure sounds crazy t' me!"

Young Cy used to nod with them. It did seem pretty crazy, this war business; and yet, after his first glimpse of that tiny wasplike fighting plane in the photograph, with its paint-pony markings and the hawk-faced, young-old pilot in the cockpit, the kid had felt a strange urge stirring within him.

He had sat on a hill one day shortly afterward and watched a pair of golden eagles wheeling and diving in the bright sunlight. It must feel grand to fly like that, he thought; to swoop and climb in the stainless blue sky, to gaze down with eagle eyes at plodding antlike mortals far below. Cy had pretended that sunny afternoon that one of the tawny birds aloft was the pinto plane of the newspaper photo and the other a black-crossed German ace out to make a kill. In Cy's fervid imagination the golden eagles were transformed into vividly painted battle planes, spitting hot lead at each other in a duel to the death.

The great world struggle across the distant Atlantic began to take on a new meaning for the boy. In the air, at least, the War held dreams of bright romance. A knightly jousting of winged tricolored Galahads and the flapping blood-dyed dragons of the Kaiser. The



"Cy" Hawkins

bugle call to high adventure rang clearly and compellingly in the ears of the young ranch lad. Cy Hawkins knew, deep in his heart, that he was of the eagle breed. He would fly!

Old man Hawkins made little fuss about the kid's running off. Cy was a big husky boy, he knew; large for his age, well able to take care of himself. Hell's bells, hadn't his old man served more than ten years in the cavalry during the Indian wars? Why, the kid was even named after General Crook, the famous Indian fighter who had been his dad's commanding officer. Old man Hawkins was secretly proud that young Cy had a share of the family's fighting streak. Of course, this business of sailing up into the air to do your battling was something new to a veteran horse soldier, but fighting was fighting, the old man figured, whether you did your shooting off a cayuse or in one of them cloud-jumping doodle-bugs.

Old man Hawkins looked again at the snapshot of young Cy, now resplendent in the uniform of a Canadian flying cadet. That there airship seemed a mite rickety, but he guessed it was all right. The lad had already soloed, whatever in tarnation that meant, and was now ready for advanced training. Cy's letter was full of a lot of other trick words and terms that his dad couldn't make head or tail of. All he was sure of was that the kid was flying and was happy.

A couple of weeks later, Cy's father received another hasty scrawl in the mail. His son was feeling fine, in excellent health—and on his way across the broad Atlantic, bound for Europe!

IN ENGLAND the youthful volunteer from the ranch country went through the regular routine that produced the war-time pilots of the Royal Flying Corps. There were other Americans among the students, but most of them older and more mature men. How-

ever there was a scattering among the "bloody Yanks," of young kids like Cy who had lied about their ages in order to get into the service. The Texas youngster soon made some good friends among this crowd and, between ground school, flying lessons and jaunts to town, he had little time for homesickness for the cow waddies of the Hawkins spread in far-away Texas.

In due time the kid and his friends received their "wings" and were transferred to advanced schools. Cy went to the combat school at Ayr in Scotland and began combat training on Camels and S. E. 5s. Before long he became accustomed to the fast, highly maneuverable single-seaters and his days were spent in practicing formation flying, combat acrobatics and firing on the machine-gun targets.

Young Hawkins did pretty well. He was not only getting bigger physically, but was also learning something about a world that the Texas ranch lad hadn't even dreamed of. Gradually he lost his bashfulness, was able to talk in the language of men to other fighting men like himself. Cy was invited to their parties and, during the short periods of leave, visited some of their homes. The intimate view of English family life and a realization of the plucky way in which the old folks in England were "carrying on" so bravely, confirmed in the young American a determination to do his bit to bring the War to a successful end.

Arrived in France, Cy Hawkins was posted to an S. E. 5 squadron commanded by Major Wyndam, a trim young example of British officer. Although not very much older than Cy in years, the major was a veteran of the War in the air and already had a tally of no less than sixteen official E. A's to his credit. The two and a Yank called Shorty, became quite friendly. After a while the three spent their leaves together, either in Paris or back in "Blighty" with Wyndam's family.

The aerial activity was light at the time young Hawkins arrived at the front. In the weeks that followed, Cy had a chance to become thoroughly acclimated to the life and technique of the War in the air. This was a lucky break for the kid for he was able to get through that first deadly month so fatal usually to young pilots.

The first few fights that the Texas kid participated in were sharp, sudden affairs, over almost before he realized that a fight was in progress. In time he learned to squint past his thumb into the sun to spot distant ships, to distinguish between the silhouettes of friendly and enemy planes. Constant practice at the machine-gun butts soon turned him into a first-rate shot with the twin Vickers nestling under the cowling of his S. E. 5.

Between patrols, Cy spent all his time in the air, perfecting his knowledge of combat tactics in mock fights with his friendly commander. At first the major was invariably the winner; but as Cy's experience increased, he became more and more able to hold his own against the cunning tactics of the veteran commander. So that, when at last the youthful Yank was thrown into the whirling turmoil of his first individual air fight, he found himself more than equal to his black-crossed opponent. Grimly, he maneuvered the bright-colored Fokker into the cross hairs of his machine-gun sight and sent the enemy ace hurtling earthward in flaming ruin.

Back at the airdrome young Cy Hawkins was called upon to set up drinks for the squadron in celebration of his first "confirmed *decendu*." He was a real fighting pilot at last! Months later old man Hawkins received a photo of his son sitting proudly in a bullet-scarred S. E. 5 that sported the markings of an Indian pony and bore on a white patch just below the cockpit the Lazy H of

the Hawkins ranch under a line of letters that spelled: THE TEXAS KID.

Cy loved it: the fighting, the flying, the grim, friendly talk of brave men. To Cy the war was a thrilling game—until that fatal day when Major Wyndam went west. The lad from Texas never knew who fired the bullet that killed his friend. All he knew was that the gallant major had gone down.

Cy never felt so young after that. He recuperated at the base hospital where he had been taken after being forced down on his way back to the home airdrome.

The saddened young Texan never returned to his squadron. During his own convalescence at the hospital, America had at last entered the War. At once, Cy made application for a transfer to the newly organized air corps of his own country.

After the signing of the armistice, Cy Hawkins got homesick for a sight of his native Texan Panhandle. As soon as he was demobilized he hurried back to his father's ranch. The peace and quiet of the old place was soothing and restful after the hellish activity of the western front of war-time France. Young Cy, no longer a carefree kid, except in years, loafed around, taking a man's part in the quiet routine of working the Hawkins herds.

BEFORE LONG, however, Cy invested the remnants of his pay as a flying officer in the purchase at one of the government sales of surplus equipment, of a second-hand "Jenny." The job of tuning up the old crate created a new interest in the young flier's life and Cy was soon hopping all over the district in his reconditioned plane. This was the first flying machine that many of the natives of the Panhandle had seen. Before he knew it, young Cy Hawkins became known throughout the cattle country as the "Flying Cowboy."

His various trips in the air took him

down along the border where he served for a time as an unofficial auxiliary of the Texas Rangers. When the duties of that famous organization became more and more taken up with the prevention of whisky smuggling, Cy signed up as a flier and instructor for the Federal forces in Mexico. He saw hard service and had many hairbreadth adventures during the frequent campaigns against bandits and the bloodthirsty and deadly Yaquis. More than once the young Texan's ability with airplane, six-gun and horse, saved his reckless life. It was in these Mexican wars that the Cowboy Flier became an expert at the difficult business of accurate aerial bombing and ground strafing.

From Mexico, Cy drifted down through Central and South America, selling his ability as an aerial warrior, first to one dark-skinned dictator, then to another. He served at various times under practically all the flags and revolutionary standards south of the Rio Grande.

Once more homesick for the U. S. A., the Flying Cowboy returned again to his father's ranch where he found old man Hawkins, still hale and hearty, running the old Lazy H spread with as firm a grip as ever. After a long, pleasant stay, Cy drifted on. Eventually he landed a job with one of the early air-mail contractors, piloting heavy loads of Uncle Sam's mail back and forth on

one of the most difficult stretches of the whole continental route.

It was during this service that Cy first met Bill Barnes. The two clicked at their very first meeting. They became companions and trusted friends. When Bill Barnes finished the amazing and grueling long-distance flight that made him instantly a world celebrity, Cy Hawkins was one of the first to shake his hand on his return.

During the difficult days that followed, Cy's air experience and his loyalty and hard-boiled shrewdness were of enormous assistance to the famous young airman who had electrified the world with his daring and ability. When Bill Barnes founded the Air Adventurers, the name of Cy Hawkins, the Flying Cowboy from Texas, was among the first inscribed on the roster.

It's a proud list of names. No room for laggards or poor sports. Every one of the men associated with Bill Barnes has long since proved his worth as a fighter. Cy is ace-high with all of them. A broncho-busting kid on the lonely western plains, a war pilot at sixteen, Texas Ranger, air mail, bathed in blood and steel in every country south of the Rio Grande—Cy Hawkins is a man who knows his way around and can take care of himself in a fight or a frolic. He enjoys the respect and affection of Bill Barnes, Shorty Hassfurter, little Sandy and all the rest of the gang.

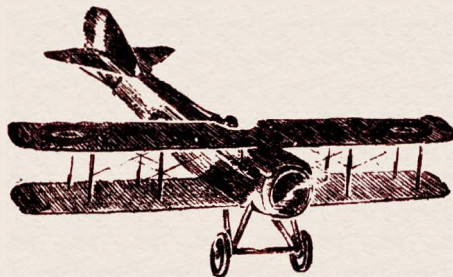

WANTED MEN FOR TEA and COFFEE ROUTES

make up to \$6.00 a week

\$103.32 IN A WEEK

**NO EXPERIENCE NEEDED—I WILL GIVE YOU
WHAT LITTLE TRAINING NECESSARY—NO
RED TAPE—EARNINGS START AT ONCE**

The future welfare of thousands of deserving men who heed this announcement may be vitally affected. Many who have been beset with financial distress can find prompt and permanent relief from their money worries.

FOR YEAR 'ROUND INCOME

Stop and think how wonderful it would be to have a nice income every week in the year. No more tramping around looking for work. No more "penny pinching". Have money to help pay your nagging bills—buy clothing—pay off the mortgage—buy yourself a home—put money in the bank—or whatever your heart desires. That's the kind of a business opportunity I am offering you.

TEA AND COFFEE ROUTES PAY BEST

Everybody knows there is nothing better than a good weekly route for a fine, steady income. These Tea and Coffee Routes pay far better than most because you supply nearly 300 necessities—things people use daily in order to live. You simply take care of the customers' orders on the route in your locality. You collect all the cash and keep a big share of it just for looking after the orders, delivering the goods, and taking care of the business. I furnish you with hundreds of fine premiums and special bargains to offer your customers with Tea, Coffee, Spices, Extracts, Baking Powder and other high quality products. Hundreds are now waiting to be served in many localities. Daily and weekly earnings mount steadily where you call on your route regularly.

YOUR OWN CARRIAGES AT WHOLESALE PRICES

When I send you instructions for making money on my new neighborhood Tea and Coffee Route Plan, I also give you rock-bottom wholesale prices on your own groceries and household necessities. This is

in addition to your regular daily earnings, so you make big money in cash and save big money on the things you use in your home.

GO TO WORK AT ONCE

My new plan provides immediate cash earnings. As long as you are honest and reliable you are eligible for one of these routes. I want someone in every territory because I have opened up my big plant to full capacity. I am going to help a lot more people earn more money at once. You can have one of these good paying routes right in your own locality, right near where you live. Better send name today.

EXPERIENCE OR TRAINING UNNECESSARY

I am not nearly so much interested in your past experience as I am in your willingness to follow a few plain instructions that will tell you the inside workings of this profitable business. I will explain just how you go about placing Tea, Coffee, Spices, Extracts and Household Products with the customers on your route. I furnish everything. There is no stock to carry—you fill your orders from my big factory stock. You have entire charge of everything.

NO MORE "PENNY PINCHING"

If you have been seeking for a boss and your pay has been limited and you are tired of pinching and striving to exist, here's an opportunity to change all this. With my route plan you can stop time-



stock pinching forever. If you want earnings that run up to \$60.00 a week you can have them. Your weekly income is limited only by the time you give to the business. The more time you devote to my wonderful Route Plan, the more money you make for yourself. That's the kind of an offer I am making to you.

That's what Howard B. Heuser, Pa., made. Here's another. Sam. Beebe \$21.45 in a day and \$36.10 in a week. Albert Becker, Ill., made \$45.00 in a day and as high as \$100.00 in a week. If you have been working part time or for low wages, this is your opportunity to get more work immediately. Har. Langston, Ill., made \$1.55 in a week. George W. Crowl, Ohio, made \$51.40 in a week. These exceptional earnings show the amazing possibilities of the offer I am making you now. Better send me your name today.

FACTORY-FRESH FOODS NOW IN GREAT DEMAND

My Tea, Coffee, and other Food Products are fresh from my big, modern Pure Food Kitchens—all have been tested and approved by the American Products Co. Testing Bureau—a very high authority on quality. It's no wonder people insist on having my brand in preference to others. I'll explain all of this more fully in the big booklet that I will send you free just as soon as I get your name. My goods have been advertised nation-wide to millions of people. There is nothing new or untried about any of my plans.



DON'T SEND MONEY— JUST YOUR NAME

Don't confuse this with anything you have ever read before. I don't need your money and need people to operate good paying routes. Send me your name so I can lay the facts before you, then you can decide if the earning possibilities are satisfactory. If you act promptly it will indicate you are the right person for the route. Send name on coupon or penny postcard for free facts. Do it today.



FORD SEDAN FURNISHED TO
PRODUCERS AS AN EXTRA BONUS
NOT A CONTEST OR A PRIZE

3 THINGS TO DO

1. Mail Coupon
2. Read Facts
3. Start Making Money at Once

TEA and COFFEE ROUTE COUPON

ALBERT MILLS, President
7574 Monmouth Ave., Cincinnati, Ohio

Send me full particulars of Tea and Coffee Route Plan, showing how I can get started earning up to \$60.00 a week at once. This is without obligation to me.

Name.....

Address.....

(Please Print or Write Plainly)

CLEAN WHITE CIGARETTE
PAPER FOR CHESTERFIELDS . .

“poured”
like milk
and just
as pure . .

To make

Chesterfield cigarette paper,
the linen pulp of the flax plant is washed
over and over again in water as pure as a
mountain stream.

So thin is this crisp white paper that
an 18-inch reel contains enough for 55,000
Chesterfields—actually over 2 miles of
paper

*Chesterfield paper must be pure
Chesterfield paper must burn right
It must have no taste or odor*

*Liquid paper in
“beating” machines
of the Champagne
Paper Co.*



—the cigarette that's MILDER
—the cigarette that TASTES BETTER